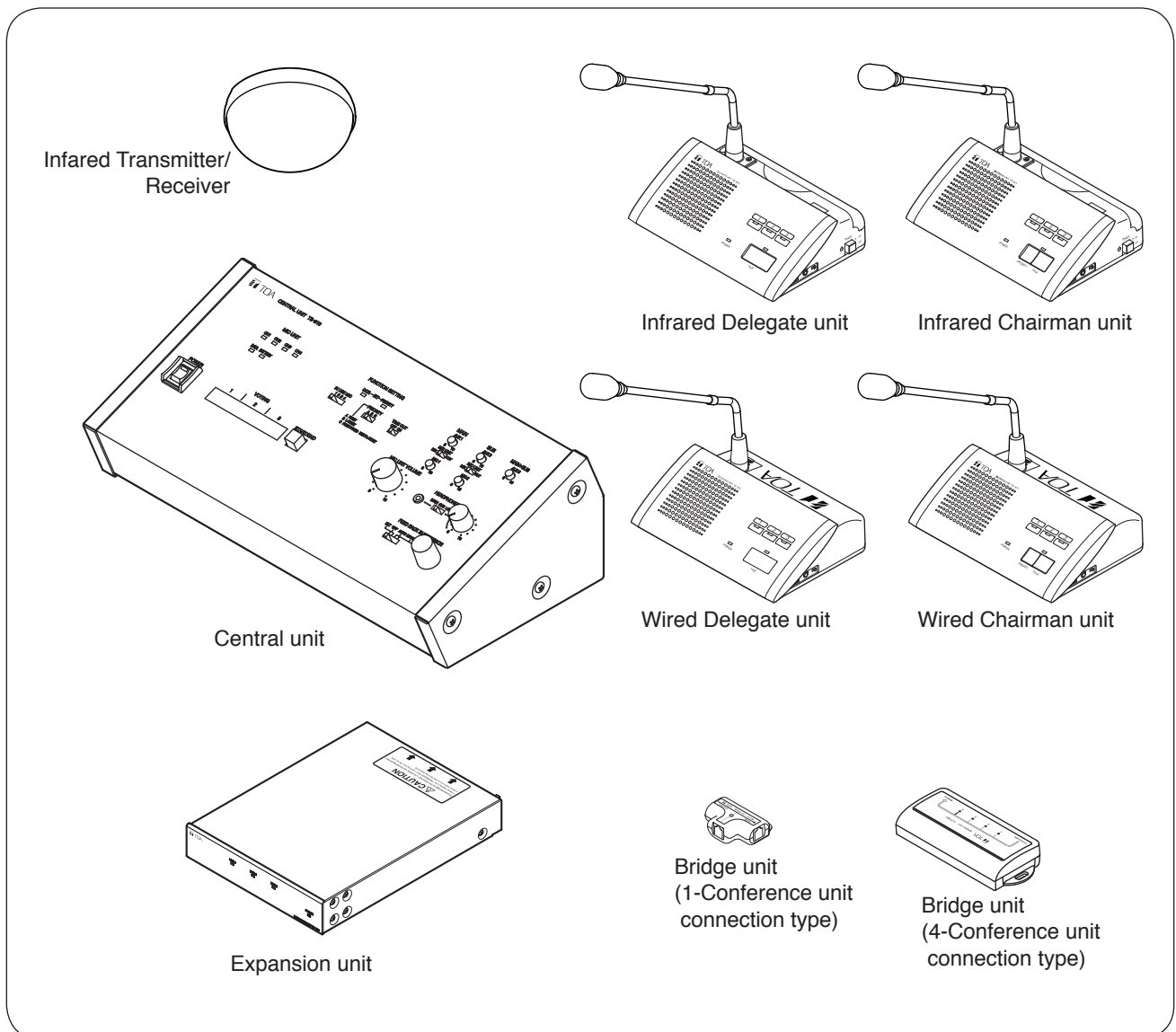

**CONFERENCE SYSTEM****TS-910 SERIES**

Thank you for purchasing TOA's Conference System.

Please carefully follow the instructions in this manual to ensure long, trouble-free use of your equipment.

# TABLE OF CONTENTS

<b>1. SAFETY PRECAUTIONS</b> .....	4
<b>2. GENERAL DESCRIPTION</b> .....	6
<b>3. SYSTEM EQUIPMENT CONFIGURATION</b> .....	7
<b>4. NOMENCLATURE AND FUNCTIONS</b> .....	8
4.1. Central Unit TS-910 .....	8
4.2. Infrared Chairman Units TS-901 and TS-801 .....	12
4.3. Wired Chairman Units TS-911 and TS-811 .....	15
4.4. Infrared Delegate Units TS-902 and TS-802 .....	18
4.5. Wired Delegate Units TS-912 and TS-812 .....	21
4.6. Expansion Unit TS-918 .....	24
4.7. Bridge Unit (4-Conference unit connection type) TS-919B4 .....	25
4.8. Bridge Unit (1-Conference unit connection type) TS-919B1 .....	25
<b>5. SYSTEM CONNECTION EXAMPLES</b> .....	26
<b>6. INFRARED TRANSMITTER/RECEIVER INSTALLATION AND CONNECTIONS</b> .....	27
6.1. Notes on Installation of the Infrared Transmitter/Receiver Unit .....	27
6.2. Infrared Service Areas .....	28
6.3. Infrared Transmitter/Receiver Arrangement Examples .....	30
6.4. Wiring between the Infrared Transmitter/Receiver Unit and the Central Unit .....	31
6.5. Mounting the Infrared Transmitter/Receiver Unit .....	33
6.6. Connections between the Infrared Transmitter/Receiver Unit and the Central Unit .....	35
<b>7. WIRED CONFERENCE UNIT CONNECTION</b> .....	39
7.1. Central Unit and Expansion Unit Connection .....	39
7.2. Expansion unit, Bridge Unit, and Wired Conference Unit Connections .....	41
7.3. Wiring .....	44
<b>8. USING WIRED MICROPHONES AND SOUND SOURCE EQUIPMENT</b> .....	45
8.1. Wired microphone use .....	45
8.2. Sound source equipment use .....	46
<b>9. RECORDING EQUIPMENT CONNECTION</b> .....	46
<b>10. CONFERENCE UNIT INSTALLATION AND SETTINGS</b> .....	47
<b>11. INFRARED CONFERENCE UNIT POWER SUPPLY</b> .....	48
11.1. BP-900 Lithium-Ion Battery .....	48
11.2. AD-0910 AC Adapter .....	50
<b>12. RACK MOUNTING</b> .....	51
12.1. Mounting the Central Unit on a Rack .....	51
12.2. Mounting the Expansion Unit on a Rack .....	52
<b>13. INSTALLATION STATUS CONFIRMATION</b> .....	53

<b>14. APPENDIX (INFRARED TRANSMITTER/RECEIVER CONNECTION)</b> .....	54
14.1. Wiring Design .....	54
14.2. Design Examples .....	56
<b>15. SIGNAL FLOW DIAGRAM INSIDE THE CENTRAL UNIT</b> ...	62

# 1. SAFETY PRECAUTIONS

- Before installation or use, be sure to carefully read all the instructions in this section for correct and safe operation.
- Be sure to follow all the precautionary instructions in this section, which contain important warnings and/or cautions regarding safety.
- After reading, keep this manual handy for future reference.

## Safety Symbol and Message Conventions

Safety symbols and messages described below are used in this manual to prevent bodily injury and property damage which could result from mishandling. Before operating your product, read this manual first and understand the safety symbols and messages so you are thoroughly aware of the potential safety hazards.



## DANGER

Indicates an imminently hazardous situation, which, if not avoided, will result in death or serious injury.

### Applicable to Lithium-ion battery

- Should the following irregularity be found during use, immediately switch off the power, take the batteries out of the unit, and keep them away from fire. Failure to do so may cause a fire or explosion.
  - If you find battery leakage, discoloration, deformation or damage.
  - If you detect smoke or a strange smell coming out from the batteries.
- Do not deform, modify, nor solder the batteries. Doing so may damage the battery's safety or protector mechanism, causing the batteries to fire, leak, or explode.
- Never short the positive and negative terminals with a wire or other metallic objects. Also, avoid carrying or keeping the batteries with metallic objects such as necklaces or hair pins. Doing so may cause the batteries to fire, explode, leak, or heat.
- Never heat the batteries nor throw them into a fire. Doing so may damage the battery's gas relief valve or safety mechanism, causing the batteries to fire or explode.
- Do not dip the batteries into water nor wet the battery terminals. This may corrode the batteries, possibly causing them to fire, explode, leak, or heat.
- Note correct polarity (positive and negative orientation) when inserting the batteries into a battery charger. Doing otherwise may cause them to fire, explode, leak, or heat.
- Do not use, keep, nor leave the batteries near fire or in locations where the temperature rises above 60°C such as in a sun-heated car. Doing so may damage the battery's safety or protector mechanism, causing the batteries to fire, explode, leak, or heat.
- Be sure to use the BC-900 charger when recharging the batteries. Using other battery charger may cause them to fire, explode, leak, or heat.
- Use the batteries only with the equipment specified. Failure to do so may cause the batteries to fire, explode, leak, or heat.
- Do not drop the batteries nor give them a shock. Doing so may damage the battery's safety or protector mechanism, causing the batteries to fire, explode, leak, or heat.
- There is a fear of losing one's eyesight if a battery leakage gets in one's eyes. Wash it away with clean water and consult a doctor immediately. If a battery leakage stains one's skin or clothes, wash it away with clean water as there is a fear of impairing the skin.



## WARNING

Indicates a potentially hazardous situation which, if mishandled, could result in death or serious personal injury.

### Applicable to Central unit, Infrared conference unit, Expansion unit, Battery charger, and AC adapter

- Use the unit only with the voltage specified on the unit. Using a voltage higher than that which is specified may result in fire or electric shock.



- Do not cut, kink, otherwise damage nor modify the power supply cord. In addition, avoid using the power cord in close proximity to heaters, and never place heavy objects -- including the unit itself -- on the power cord, as doing so may result in fire or electric shock.

**Applicable to Central unit, Conference unit, Expansion unit, Battery charger, and AC adapter**

- Do not expose the unit to rain or an environment where it may be splashed by water or other liquids, as doing so may result in fire or electric shock.
- Avoid installing or mounting the unit in unstable locations, such as on a rickety table or a slanted surface. Doing so may result in the unit falling down and causing personal injury and/or property damage.



**CAUTION**

Indicates a potentially hazardous situation which, if mishandled, could result in moderate or minor personal injury, and/or property damage.

- These servicing instructions are for use by qualified personnel only. To reduce the risk of electric shock, do not perform any servicing other than that contained in the operating instructions unless you are qualified to do so. Refer all servicing to qualified service personnel.

**Applicable to Central unit**

- Be sure to follow the instructions below when rack-mounting the unit. Failure to do so may cause a fire or personal injury.
  - Install the equipment rack on a stable, hard floor. Fix it with anchor bolts or take other arrangements to prevent it from falling down.
  - To rack-mount the unit, use the supplied rack mounting hardware.
  - When connecting the unit's power cord to an AC outlet, use the AC outlet with current capacity allowable to the unit.

**Applicable to Central unit, Infrared Conference unit, Expansion unit, Battery charger, and AC adapter**

- Never plug in nor remove the power supply plug with wet hands, as doing so may cause electric shock.
- When unplugging the power supply cord, be sure to grasp the power supply plug; never pull on the cord itself. Operating the unit with a damaged power supply cord may cause a fire or electric shock.
- When moving the unit, be sure to remove its power supply cord from the wall outlet. Moving the unit with the power cord connected to the outlet may cause damage to the power cord, resulting in fire or electric shock. When removing the power cord, be sure to hold its plug to pull.

**Applicable to Central unit, Conference unit, Expansion unit, Battery charger, and AC adapter**

- Avoid installing the unit in humid or dusty locations, in locations exposed to the direct sunlight, near the heaters, or in locations generating sooty smoke or steam as doing otherwise may result in fire or electric shock.

**Applicable to Lithium-ion battery**

- When you discard batteries, please contact the local dealer from whom you bought.

**Applicable to Central unit, Conference unit, Expansion unit, and Battery charger**

This is a class A product.

In a domestic environment this product may cause radio interference in which case the user may be required to take adequate measures.

## 2. GENERAL DESCRIPTION

The TOA TS-910 Series conference system permits both its infrared wireless system unit and wired system unit via CAT-5 LAN cable connections to be used in combination.

The wired Chairman and Delegate units (collectively referred to as "Conference units") are connected to the Central unit via the wired Expansion unit and Bridge unit.

The Infrared Conference units provide wireless communication via the Infrared Transmitter/Receiver unit connected to the Central unit. Since wiring to the individual Conference units is not required, they can be easily installed in freely versatile configurations.

A total of up to 192 Infrared and Wired Conference units can be connected to the Central unit of each system.

The Infrared Transmitter/Receiver unit is required for connection of the Infrared Conference units. (Refer to p. 27.)

The Expansion unit and Bridge unit are necessary for connection of the Wired Conference units. (Refer to p. 39.)

The Central unit is used to perform system function settings, status display, etc.

### 3. SYSTEM EQUIPMENT CONFIGURATION

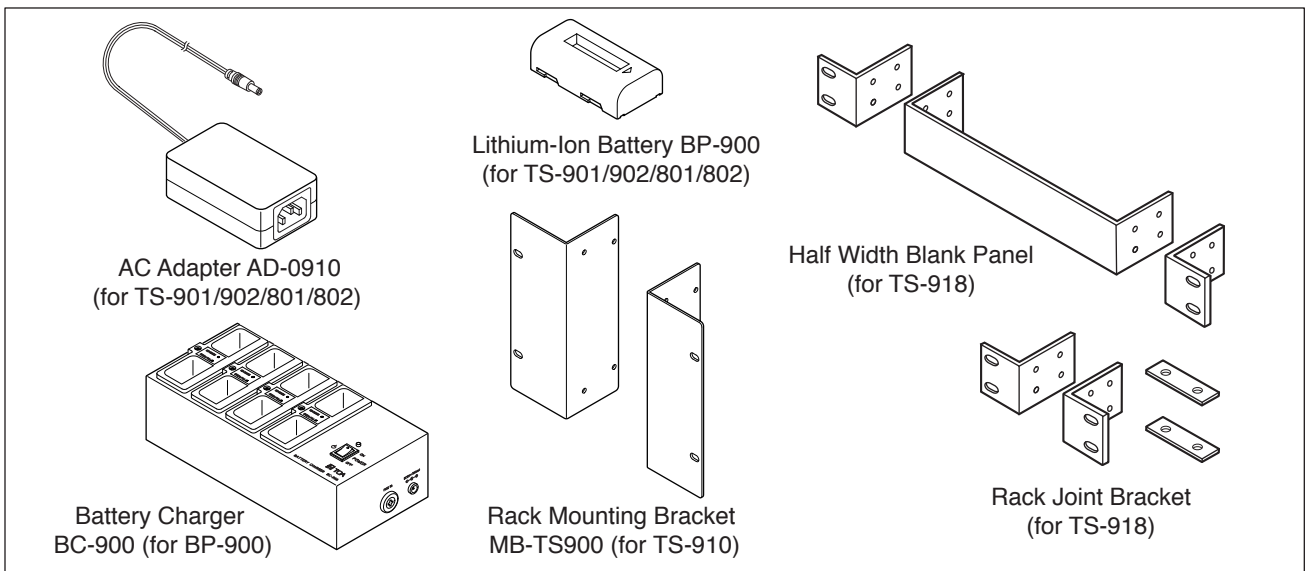
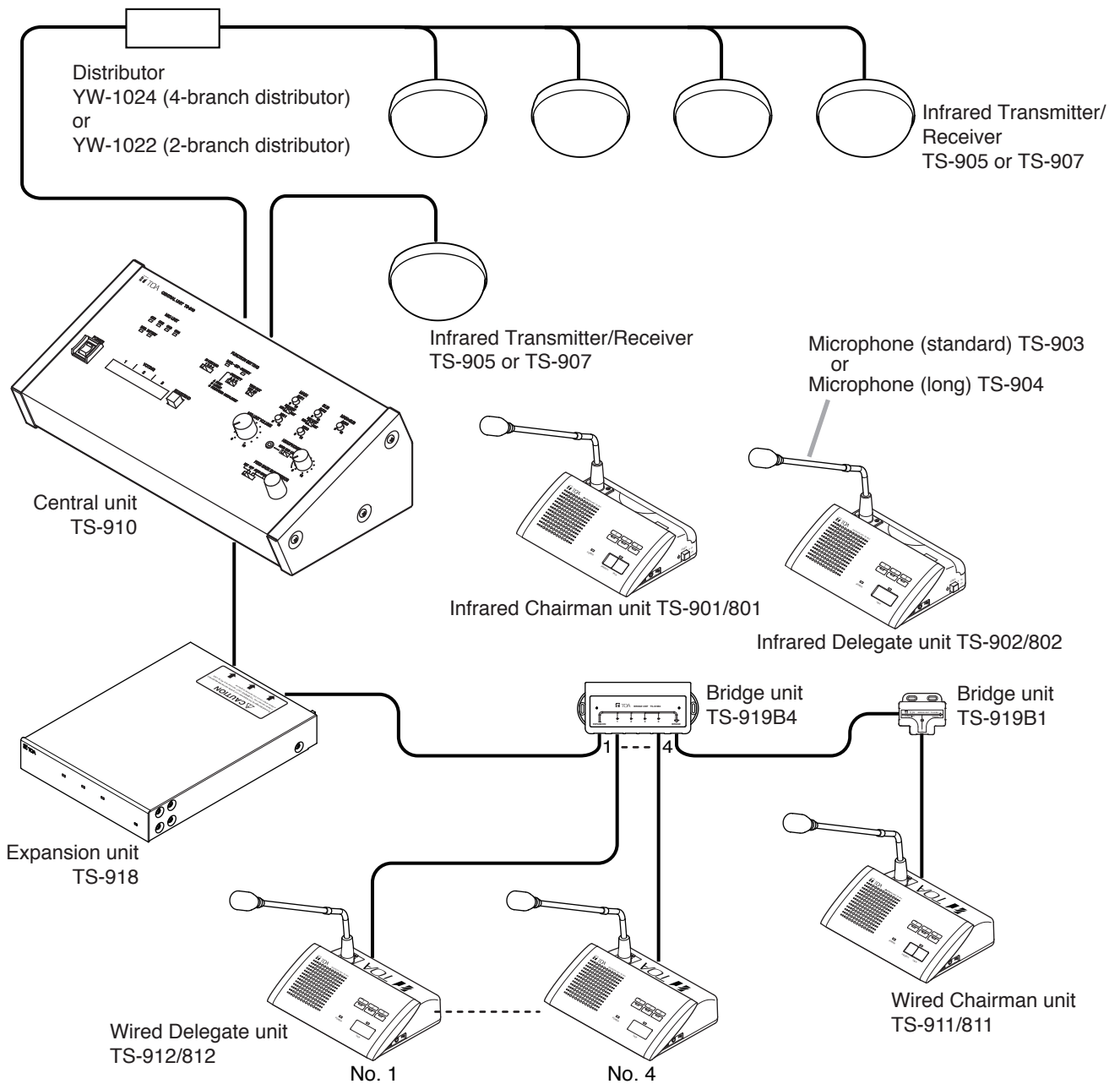

## 4. NOMENCLATURE AND FUNCTIONS

### 4.1. Central Unit TS-910

[Top]

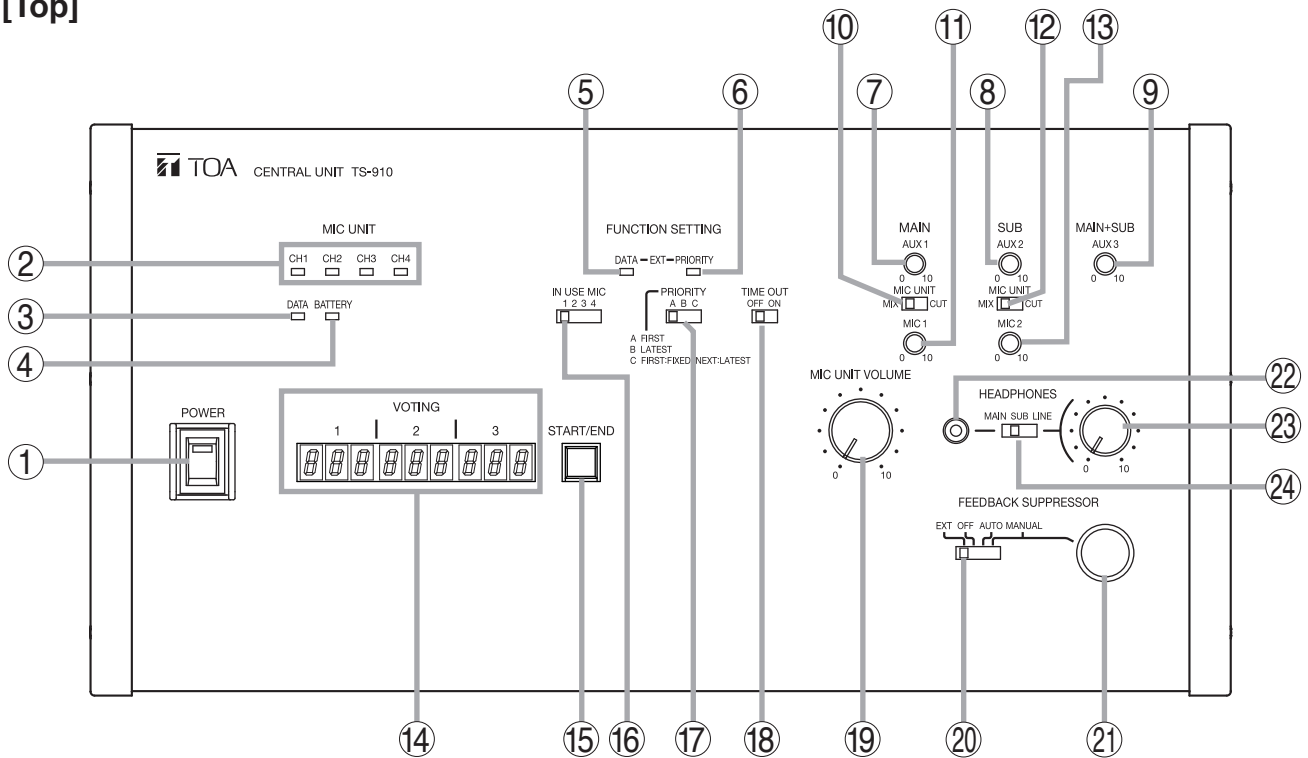

#### 1. Power switch

Setting this switch to the ON position causes the Power indicator to light.

#### 2. Audio signal receiving indicators

Light up when audio signals are received from Conference units. Audio signals are transmitted or received through 4 channels. The number of channels to be used can be set with the Simultaneous Speaker No. Setting switch (16). These indicators light in the same number as that of the Conference units currently being used for speech. (Which indicator will light is not specified.)

#### 3. Data signal receiving indicator

Lights when control data is received from the Conference unit.

#### 4. Battery indicator

Flashes when the lithium-ion battery of the Infrared Conference unit nears complete discharge. (In this event, the Microphone In-Use indicator and the Speech indicator on the corresponding unit also flash.)

#### Note

Be sure to immediately replace the lithium-ion battery of the corresponding unit with the fully-charged one if this indicator begins to flash.

#### 5. External control communication indicator

Remains lit during communications with a computer (PC) or operation panel connected to the External Control terminal (30) or (32).

#### 6. External control priority indicator

Either lights or flashes when a PC or operation panel connected to the External Control terminal (30) or (32) performs priority operation. In this event, three function setting switches (16), (17), and (18) cannot be used.

#### 7. AUX 1 input volume control

Adjusts the input signal level of the AUX 1 Input Terminal (28) located on the rear panel. Speech input to the AUX 1 terminal is output to the base language channel\*1.

#### 8. AUX 2 input volume control

Adjusts the input signal level of the AUX 2 Input Terminal (26) located on the rear panel. Speech input to the AUX 2 terminal is output to the translation language channel\*2.

#### 9. AUX 3 input volume control

Adjusts the input signal level of the AUX 3 Input Terminal (25) located on the rear panel. Speech input to the AUX 3 terminal is output to both the base language\*1 and translation language\*2 channels.

#### 10. Microphone Mix/Cut switch (for the base language channel)

MIX: Speech input from the Conference units, and AUX 1 and MIC 1 input signals are output to the base language channel\*1, and recording and line outputs.

CUT: Speech input from the Conference units is not output to the base language channel\*1. The AUX 1 and MIC 1 input signals are not delivered to the recording and line outputs.

**Note**

This switch is factory-preset to the MIX position.

**11. MIC 1 input volume control**

Adjusts the input level of the MIC 1 Input Terminal (29) on the rear panel. Signals input to the MIC 1 terminal are output to the base language channel\*1.

**12. Microphone Mix/Cut switch  
(for the translation language channel)**

MIX: Speech input from the Conference units is output to the translation language channel\*2.

CUT: Speech input from the Conference units is not output to the translation language channel\*2.

**Note**

This switch is factory-preset to the MIX position.

**13. MIC 2 input volume control**

Adjusts the input level of the MIC 2 Input Terminal (27) on the rear panel. Signals input to the MIC 2 terminal are output to the translation language channel\*2.

**14. Voting result display**

Computes the number of votes cast by individual Conference units for categories 1 – 3 and displays the result after voting completion.

**15. Voting start/end button**

Holding down this button for 1 second or more permits the Central unit to accept voting. To terminate voting, hold down the button again for 1 second or more. If this button is held down for 1 second or more once again, the Voting Result Display (14) is turned off. (Refer to the separate Operating instructions.)

This button is also used to confirm installation conditions for the Infrared Transmitter/Receiver unit, the Conference unit. (Refer to p. 53.)

**16. Simultaneous speaker No. setting switch**

Used to set the number of Conference units that can be simultaneously operated. The indications [1], [2], [3], and [4] represent the number of simultaneously operable units. (Refer to the separate Operating instructions.)

**Note**

This switch is factory-preset to the [1] position.

**17. Speech priority selector switch**

Determines the priority mode when the Talk key of the Conference unit is pressed. (Refer to the separate Operating instructions.)

A: First-in-first-out priority

B: Last-in-first-out priority

C: Priority fixed for the first unit, and last-in-first-out priority for all other subsequent units.

**Note**

This switch is factory-preset to the [A] position.

**18. Mic-off setting switch**

Automatically turns off Conference unit microphones 30 seconds after speech is completed if the user should neglect to turn off the microphone. (Refer to the separate Operating instructions.)

**Note**

This switch is factory-preset to the OFF position.

**19. Speech volume control**

Adjusts the microphone volume of the Conference unit.

**20. FBS (Feedback Suppressor) Switch**

Use to set FBS operation.

EXT: Select when using an external graphic equalizer.

OFF: Select when not using the FBS function.

AUTO: Select to suppress acoustic feedback by automatically searching for a frequency generating acoustic feedback.

MANUAL: Select to manually search for a feedback-generating frequency.

For details, refer to the separate Operating instructions.

**21. FBS (Feedback Suppressor) control**

Rotate to search for a frequency generating acoustic feedback when the FBS switch (20) is set to "MANUAL."

For details, refer to the separate Operating instructions.

**22. Headphone jack (Mini-jack)**

Connects to headphones.

**23. Headphone volume control**

Adjusts the sound volume of the headphones.

**24. Headphone channel selector switch**

Used to choose the output to be monitored by a connected headphones from the following three sources: Base language (MAIN), Translation language (SUB), and Line (LINE) channels.

**Note**

This switch is factory-preset to the MAIN position.

\*1 Base Language: Mixed audio signals from the AUX 1 input, MIC 1 input, and in-use Conference units.

\*2 Translation Language: Mixed audio signals from the AUX 2 input, MIC 2 input, and in-use Conference units.

## [Rear]

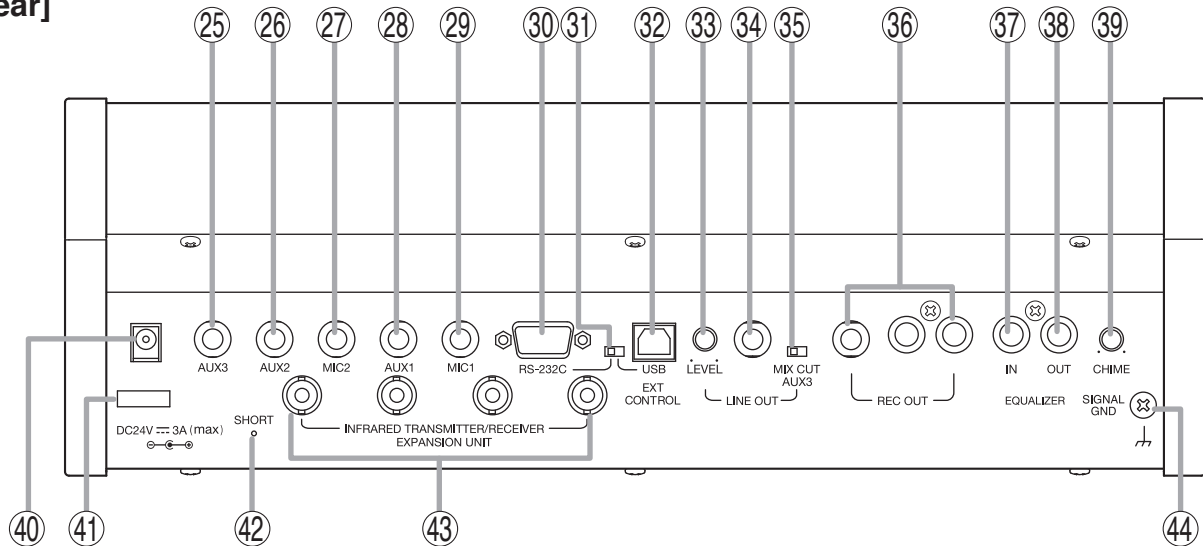

### 25. AUX 3 input terminal

–20 dB\*, 10 k $\Omega$ , unbalanced, phone jack.  
Connect a CD player, tape recorder, or other similar equipment to this terminal. Speech input connected to this terminal is relayed to both the base and translation language channels.

### 26. AUX 2 input terminal

–20 dB\*, 10 k $\Omega$ , unbalanced, phone jack.  
Connect a CD player, tape recorder, or other similar equipment to this terminal. Speech input connected to this terminal is relayed to the translation language channel.

### 27. MIC 2 input terminal

–60 dB\*, 600  $\Omega$ , unbalanced, phone jack.  
Connect a wired microphone to this terminal. Speech input from the microphone connected to this terminal is relayed to the translation language channel.

### 28. AUX 1 input terminal

–20 dB\*, 10 k $\Omega$ , unbalanced, phone jack.  
Connect a CD player, tape recorder, or other similar equipment to this terminal. Speech input connected to this terminal is relayed to the base language channel.

### 29. MIC 1 input terminal

–60 dB\*, 600  $\Omega$ , unbalanced, phone jack.  
Connect a wired microphone to this terminal. Speech input from the microphone connected to this terminal is relayed to the base language channel.

### 30. External control terminal [RS-232C]

Connect this terminal to the serial port of a PC, operation panel, or other external control equipment.

### 31. External control terminal selection switch

Used to select either RS-232C (30) or USB (32) external control terminals.

### 32. External control terminal [USB]

Connects to the external control terminal of a PC, operation panel or other connected external equipment.

### 33. Level volume control

Adjusts the line output (34) volume.

### 34. Line output terminal

–20 dB\*, 10 k $\Omega$ , unbalanced, phone jack.  
Connect an amplifier, etc. for public address applications. Speech input from the Conference unit, or MIC 1, AUX 1, or AUX 3 terminals is output to this terminal. The settings of Microphone Mix/Cut switch (10) and AUX 3 Output Mix/Cut switch (35) determine whether or not such speech input is output.

### 35. AUX 3 output Mix/Cut switch

Determines whether or not speech input is relayed from AUX 3 terminal to the line output (34). Set this switch to MIX in normal use, and to CUT to enable conference participants in other rooms to avoid potential audio feedback while speaking.

### 36. Recording output terminal

–20 dB\*, 10 k $\Omega$ , unbalanced, phone jack, RCA jacks.  
Connect an Alternate Recording Deck or MD recorder. An amplifier can also be connected for public address applications. The same speech signal as the line output and that of AUX 3 terminal are output to this terminal.

### 37. Graphic equalizer input terminal

–20 dB\*, 10 k $\Omega$ , unbalanced, RCA jack.  
Connect this terminal to the graphic equalizer's output terminal.

**38. Graphic equalizer output terminal**  
–20 dB\*, 10 kΩ, unbalanced, RCA jack.  
Connect this terminal to the graphic equalizer's input terminal.

**39. Priority chime volume control**  
Adjusts the output volume of the chime tone that sounds when the Priority Speech key on the Chairman unit is pressed.

**40. DC inlet**  
Connect the supplied AC adapter to this terminal.

**41. Cable clip**  
Run the AC adapter cable through this clip to prevent its plug from being removed from the DC inlet.

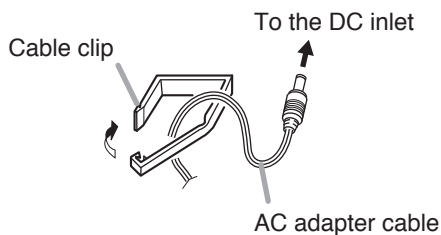

**42. Short circuit indicator**  
Lights when the Infrared Transmitter/Receiver unit or its connected cable is shorted.

**43. Infrared transmitter/receiver and Expansion unit I/O terminals**  
Connect the Infrared Transmitter/Receiver unit, Expansion unit, or Distributor to these terminals.

[Infrared Transmitter/Receiver connection]  
By using the YW-1022 (2-branch distributor) and/or YW-1024 (4-branch distributor), the following maximum number of Infrared Transmitter/Receiver units can be connected: 16 units when they are all TS-905 units, 12 units when they are all TS-907 units. (Also 12 units when both models are mixed.)

[When connecting only the Expansion unit]  
By using the YW-1022 (2-branch distributor) and/or YW-1024 (4-branch distributor), up to 8 TS-918 Expansion units can be connected.

**44. Functional earth terminal**  
Hum noise may be generated when external equipment is connected to the unit. Connecting this terminal to the functional earth terminal of the external equipment may reduce the hum noise.  
**Note:** This terminal is not for protective earth.

\* 0 dB = 1 V



## 4.2. Infrared Chairman Units TS-901 and TS-801

[TS-901 Top]

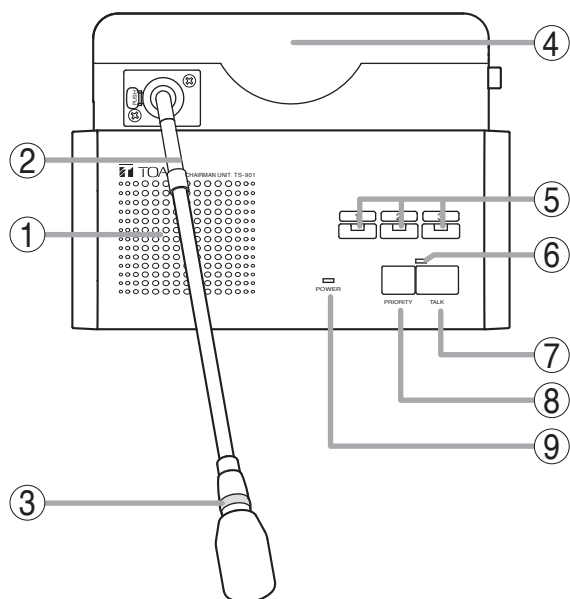

[TS-801 Top]

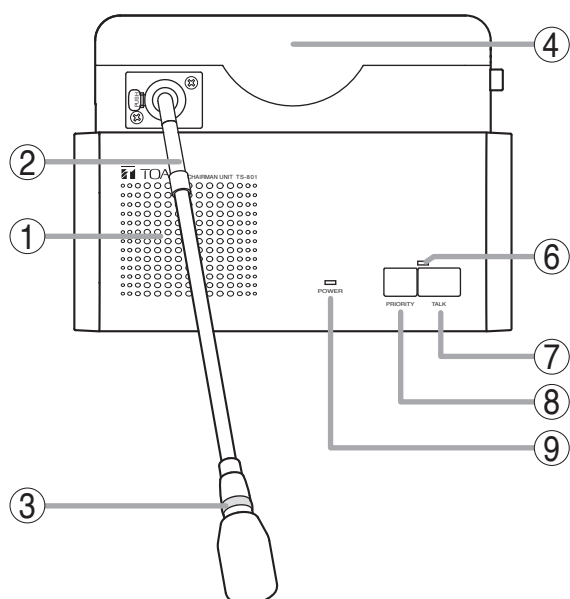

**Note:** No microphone is supplied with the TS-901/801.

### 1. Monitor speaker

Speech signals from other Conference units and other audio signals from the Central unit are output from this speaker. (Refer to the table below.)

Model	Output signal
TS-901	Base language or Translation language <b>Note:</b> Switchable by the Monitor selector switch (17).
TS-801	Base language

Use the right-side Monitor Volume Control (16) to adjust the volume. No sound is output from the speaker of the unit in use while speaking.

### 2. Microphone

Use either the TS-903 (Standard) or TS-904 (Long) dedicated microphone.

### 3. Microphone in-use indicator

Lights when the microphone is turned on (for speech) and flashes when the battery level is low.

### 4. Infrared emitter/detector

The device used to transmit and receive infrared communication signals is built inside this panel.

#### **Note**

Never place any object that could block infrared signal access to this part of the unit, as this would prevent the unit from transmitting or receiving its required infrared signal.

### 5. Voting keys (TS-901 only)

Use these keys to start, end, and cast voting. The voting status indicator is provided on each key.

### 6. Speech indicator

Remains lit while the microphone is in use (during

speech). The indicator flashes when the unit is out of the communications service area.

### 7. Talk key

When this key is pressed, both the Microphone In-Use indicator (3) and the Speech indicator (6) light, and the microphone turns on. Pressing this key again turns off both indicators and the microphone.

### 8. Priority speech key

Gives speaking priority to the current speaker. When this key is used for speech, no other delegate units can be used. Also, only the current speech made with the Priority speech key is output at the Central Unit's recording and line outputs.

The key has 2 different operating modes, PTT and ALT, which can be selected with the Priority speech key operation setting switch (14).

- When PTT mode is selected, the microphone only turns on while the key is pressed, during which time the Speech (6) and Microphone in-use (3) indicators remain lit.
- When ALT mode is selected, pressing the key turns on the microphone and causes the Speech (6) and Microphone in-use (3) indicators to light. Pressing the key again turns off the microphone and these indicators.

If Chime is set to sound, a chime tone sounds when the key is pressed. For the chime setting, use the Priority chime mute switch (12).

### 9. Power indicator

Lights when the power is switched ON. This indicator also flashes when the battery level is low or the unit is outside the communications service area.



## [Bottom]

Remove the cover on the bottom side of the unit to expose its setting switches.

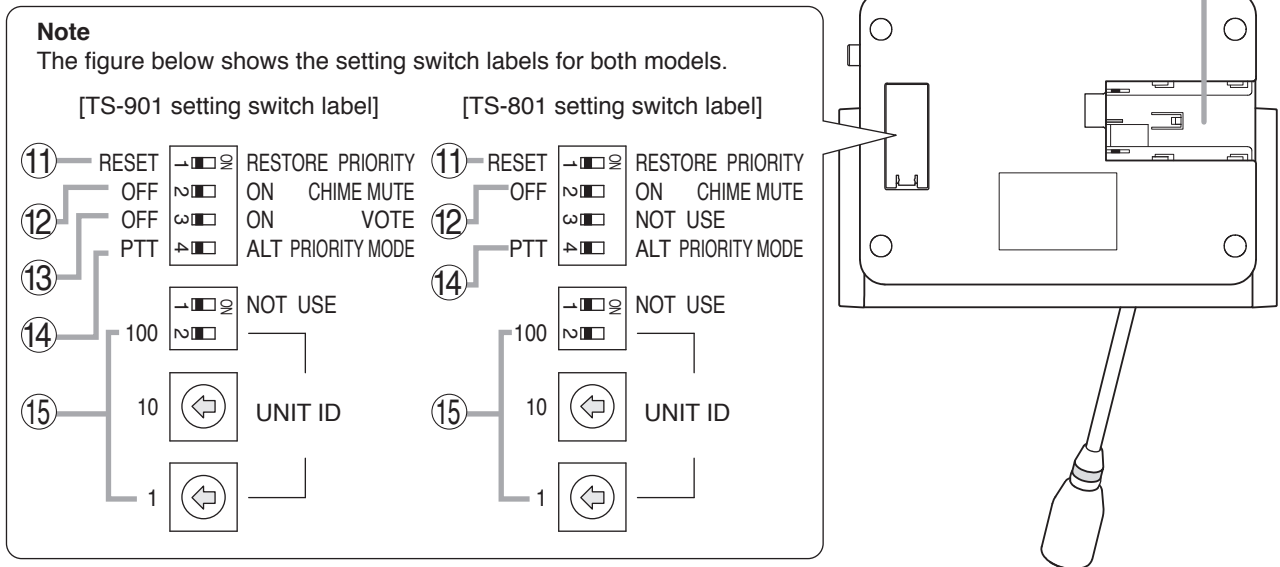

### 10. Lithium-ion battery compartment

Install only a dedicated BP-900 Lithium-Ion Battery in this compartment.

### 11. Priority operation setting switch

Following completion of a priority speech, this switch is used to reset the operating status of Conference units whose operations were interrupted by the depression of a Priority Speech key (8).

Set the switch to RESTORE in order to resume the mode in operation prior to initiation of the priority speech, and to RESET when resumption is not desired.

#### Note

This switch is factory-preset to the RESET position.

### 12. Priority chime mute switch

Disables the chime that sounds when the Priority Speech key is pressed.

Set this switch to OFF when sound output is desired, and to ON when no sound is desired.

#### Note

This switch is factory-preset to the OFF position.

### 13. Voting activation switch (TS-901 only)

Determines whether or not to start and terminate voting from the Chairman unit.

Set the switch to ON to enable voting, or to OFF to disable voting.

#### Note

This switch is factory-preset to the OFF position.

### 14. Priority speech key operation setting switch

Use to set the Priority speech key operation mode.

PTT: Speech only possible while the Priority speech key is being pressed.

ALT: Speech enabled when the Priority speech key is pressed, and disabled when the key is pressed again.

#### Note

The switch is factory-preset to PTT.

### 15. Unit address number setting switch

Set the unit address number (001 – 192), taking care to ensure that the same number is not duplicated in the system.

If the number [000] is assigned to a unit, the user of that unit cannot speak. However, the unit can be used for monitoring.

Set a numeral for the one's place and ten's place. Set this switch to OFF to set the hundred's place to "0" and to ON to set it to "1."

#### Note

This number is factory-preset to [000].

**[Right side]**

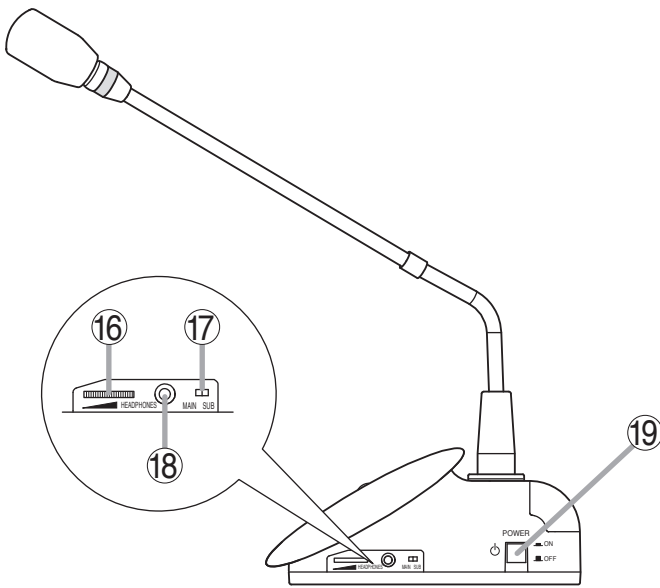

**16. Monitor volume control**

Adjusts the output volume of the monitor speaker and right-side headphone output.

**17. Monitor selector switch (TS-901 only)**

Selects either Base Language or Translation Language for the source to be output to the monitor speaker and headphones.

**18. Headphone jack**

Connect headphones to this jack (mini-jack). Connecting the headphone cuts off the output from the monitor speaker. (Refer to the table below.)

Model	Output signal
TS-901	Base language or Translation language <b>Note:</b> Switchable by the Monitor selector switch (17).
TS-801	Base language

**Note**

A headphone jack is located on both the left and right side panels.

**19. Power switch**

Press this switch to switch on the power. To switch off the power, press this switch again.

**[Left side]**

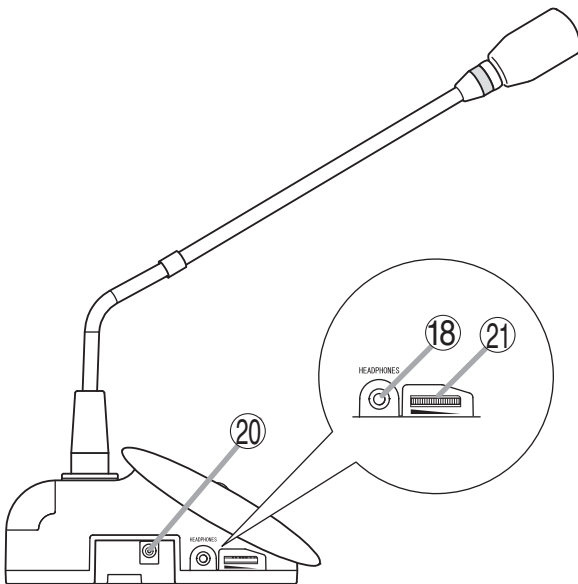

**20. DC inlet**

Connect the dedicated AD-0910 AC Adapter to this terminal.

**21. Headphone volume control**

Adjusts the output volume of the left-side headphone output.

### 4.3. Wired Chairman Units TS-911 and TS-811

[TS-911 Top]

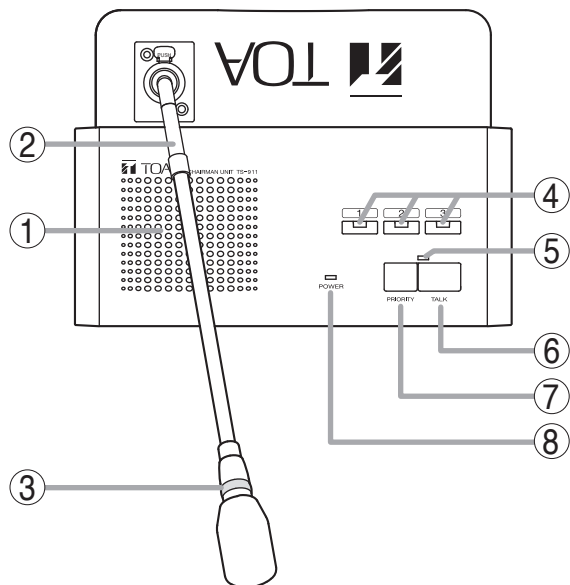

[TS-811 Top]

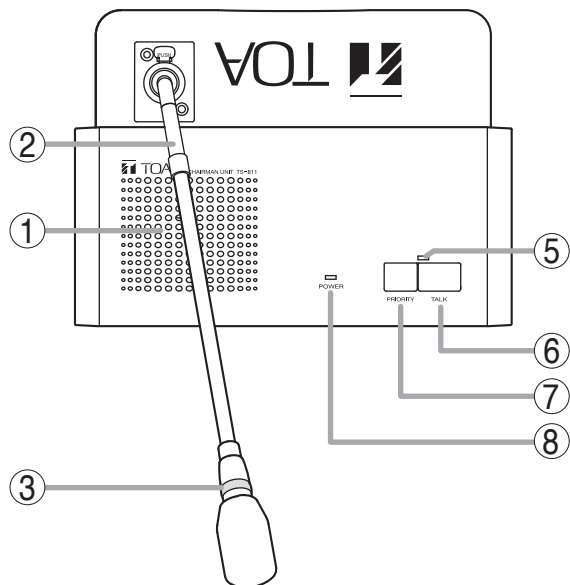

**Note**  
No microphone is supplied with the TS-911/811.

#### 1. Monitor speaker

Speech signals from other Conference units and other audio signals from the Central unit are output from this speaker. (Refer to the table below.)

Model	Output signal
TS-911	Base language or Translation language <b>Note:</b> Switchable by the Monitor selector switch (16).
TS-811	Base language

Use the right-side Monitor Volume Control (14) to adjust the volume. No sound is output from the speaker of the unit in use while speaking.

#### 2. Microphone

Use either the TS-903 (Standard) or TS-904 (Long) dedicated microphone.

#### 3. Microphone in-use indicator

Lights when the microphone is turned on (for speech).

#### 4. Voting keys (TS-911 only)

Use these keys to start, end, and cast voting. The voting status indicator is provided above each key.

#### 5. Speech indicator

Remains lit while the microphone is in use (during speech). The indicator flashes when the unit is out of the communications service area.

#### 6. Talk key

When this key is pressed, both the Microphone In-Use indicator (3) and the Speech indicator (5) light, and the microphone turns on. Pressing this key again turns off both indicators and the microphone.

#### 7. Priority speech key

Gives speaking priority to the current speaker. When this key is used for speech, no other delegate units can be used. Also, only the current speech made with the Priority speech key is output at the Central Unit's recording and line outputs. The key has 2 different operating modes, PTT and ALT, which can be selected with the Priority speech key operation setting switch (12).

- When PTT mode is selected, the microphone only turns on while the key is pressed, during which time the Speech (5) and Microphone in-use (3) indicators remain lit.
- When ALT mode is selected, pressing the key turns on the microphone and causes the Speech (5) and Microphone in-use (3) indicators to light. Pressing the key again turns off the microphone and these indicators.

If Chime is set to sound, a chime tone sounds when the key is pressed. For the chime setting, use the Priority chime mute switch (10).

#### 8. Power indicator

Lights when power is supplied from the TS-910 Central unit via the TS-918 Expansion unit.

**[Bottom]**

Remove the cover on the bottom side of the unit to expose its setting switches.

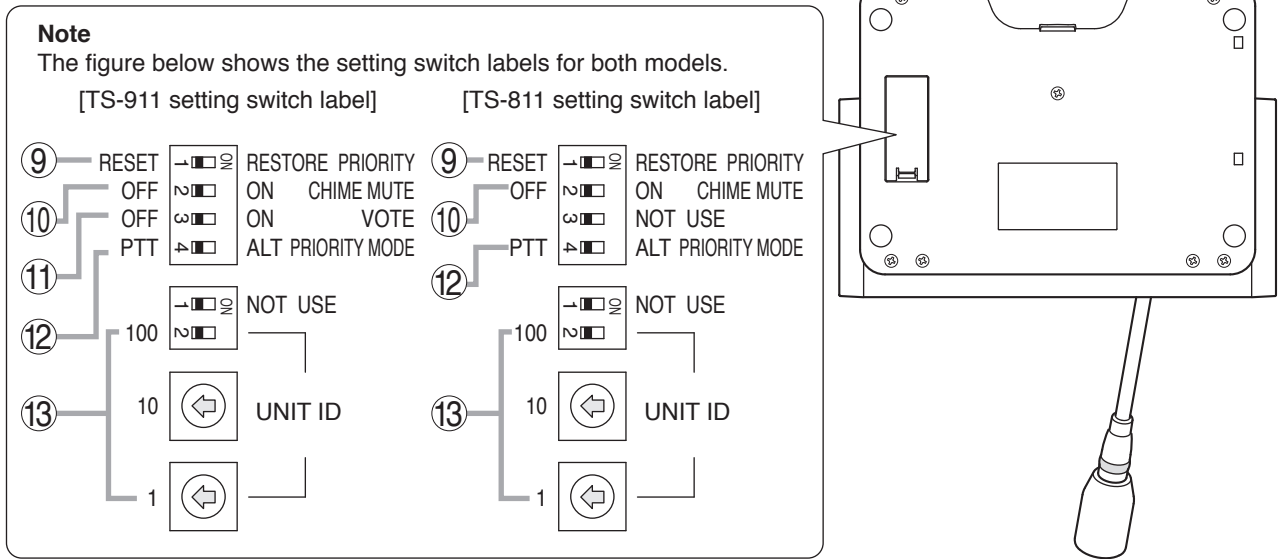

**9. Priority operation setting switch**

Following completion of a priority speech, this switch is used to reset the operating status of Conference units whose operations were interrupted by the depression of a Priority Speech key (7).

Set the switch to RESTORE in order to resume the mode in operation prior to initiation of the priority speech, and to RESET when resumption is not desired.

**Note**

This switch is factory-preset to the RESET position.

**10. Priority chime mute switch**

Disables the chime that sounds when the Priority Speech key is pressed.

Set this switch to OFF when sound output is desired, and to ON when no sound is desired.

**Note**

This switch is factory-preset to the OFF position.

**11. Voting activation switch (TS-911 only)**

Determines whether or not to start and terminate voting from the Chairman unit.

Set the switch to ON to enable voting, or to OFF to disable voting.

**Note**

This switch is factory-preset to the OFF position.

**12. Priority speech key operation setting switch**

Use to set the Priority speech key operation mode.

PTT: Speech only possible while the Priority speech key is being pressed.

ALT: Speech enabled when the Priority speech key is pressed, and disabled when the key is pressed again.

**Note**

The switch is factory-preset to PTT.

**13. Unit address number setting switch**

Set the unit address number (001 – 192), taking care to ensure that the same number is not duplicated in the system.

If the number [000] is assigned to a unit, the user of that unit cannot speak. However, the unit can be used for monitoring.

Set a numeral for the one's place and ten's place. Set this switch to OFF to set the hundred's place to "0" and to ON to set it to "1."

**Note**

This number is factory-preset to [000].

## [Right side]

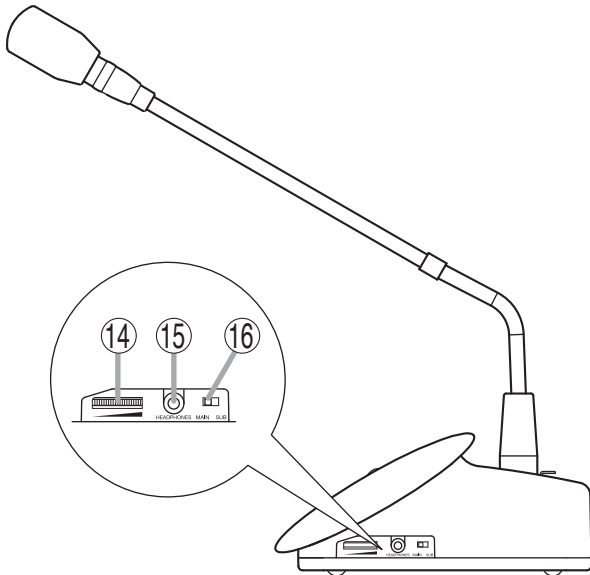

### 14. Monitor volume control

Adjusts the output volume of the monitor speaker and right-side headphone output.

### 15. Headphone jack

Connect headphones to this jack (mini-jack). Connecting the headphone cuts off the output from the monitor speaker. (Refer to the table below.)

Model	Output signal
TS-911	Base language or Translation language <b>Note:</b> Switchable by the Monitor selector switch (16).
TS-811	Base language

### Note

A headphone jack is located on both the left and right side panels.

### 16. Monitor selector switch (TS-911 only)

Selects either Base Language or Translation Language for the source to be output to the monitor speaker and headphone.

## [Left side]

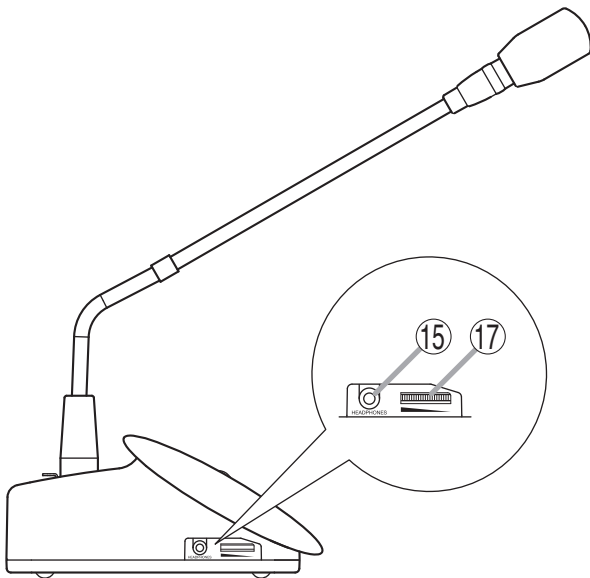

### 17. Headphone volume control

Adjusts the output volume of the left-side headphone output.

**[Rear]**

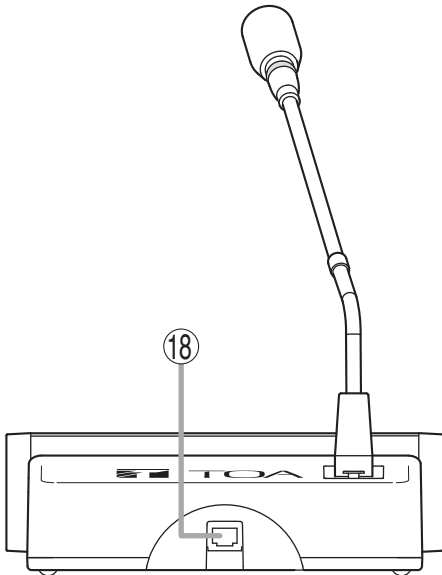

**18. Communication cable connection terminal**

Connects to the TS-919B4 or TS-919B1 Bridge unit with a CAT-5 LAN cable.

**4.4. Infrared Delegate Units TS-902 and TS-802**

**[TS-902 Top]**

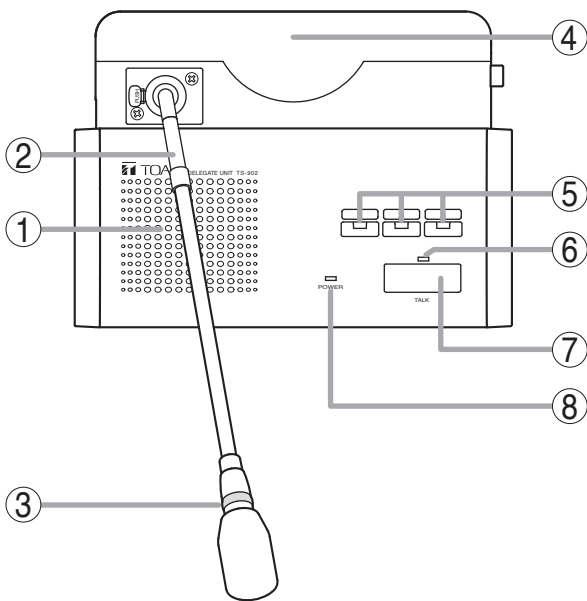

**[TS-802 Top]**

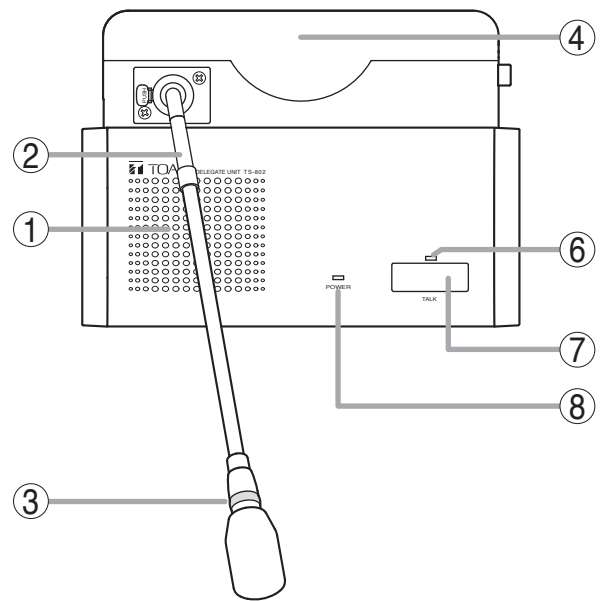

**1. Monitor speaker**

Speech signals from other Conference units and other audio signals from the Central unit are output from this speaker. (Refer to the table below.)

Model	Output signal
TS-902	Base language or Translation language <b>Note:</b> Switchable by the Monitor selector switch (12).
TS-802	Base language

Use the right-side Monitor Volume Control (11) to adjust the volume. No sound is output from the speaker of the unit in use while speaking.

**2. Microphone**

Use either the TS-903 (Standard) or TS-904 (Long) dedicated microphone.

**3. Microphone in-use indicator**

Lights when the microphone is turned on (for speech) and flashes when the battery level is low.

**4. Infrared emitter/detector**

The device used to transmit and receive infrared communication signals is built inside this panel.

**Note**

Never place any object that could block infrared

signal access to this part of the unit, as this would prevent the unit from transmitting or receiving its required infrared signal.

### 5. Voting keys (TS-902 only)

Use these keys to start, end, and cast voting. The voting status indicator is provided on each key.

### 6. Speech indicator

Remains lit while the microphone is in use (during speech). The indicator flashes when the unit is out of the communications service area.

### 7. Talk key

When this key is pressed, both the Microphone In-Use indicator (3) and the Speech indicator (6) light, and the microphone turns on. Pressing this key again turns off both indicators and the microphone.

### 8. Power indicator

Lights when the power is switched ON. This indicator also flashes when the battery level is low or the unit is outside the communications service area.

## [Bottom]

Remove the cover on the bottom side of the unit to expose its setting switches.

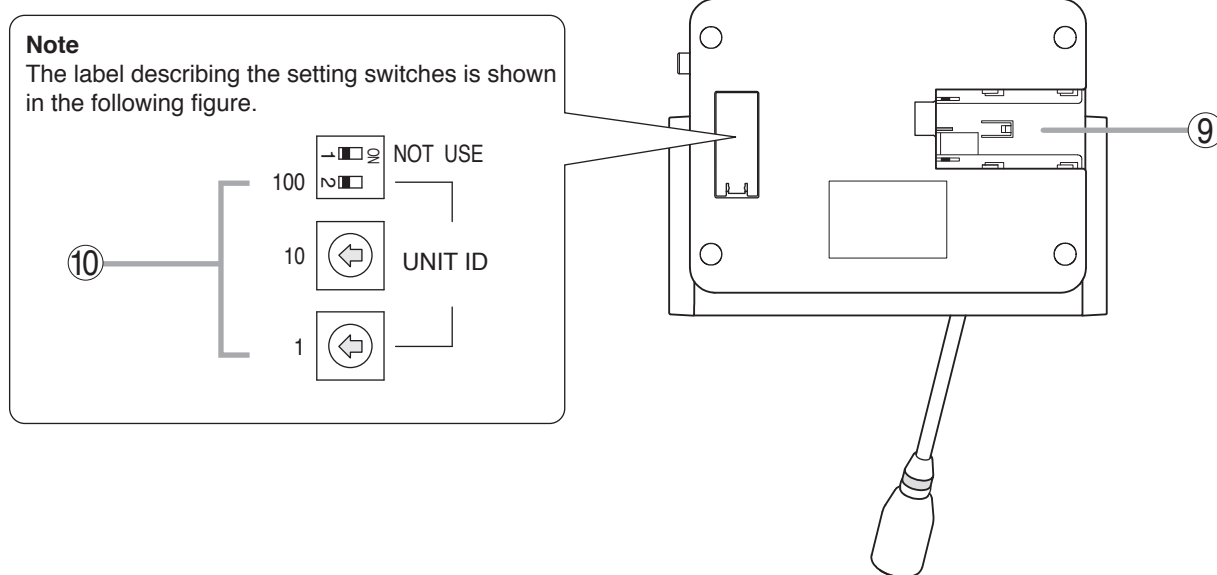

### 9. Lithium-ion battery compartment

Install only a dedicated BP-900 Lithium-Ion Battery in this compartment.

### 10. Unit address number setting switch

Set the unit address number (001 – 192), taking care to ensure that the same number is not duplicated in the system.

If the number [000] is assigned to a unit, the user of that unit cannot speak. However, the unit can be used for monitoring.

Set a numeral for the one's place and ten's place. Set this switch to OFF to set the hundred's place to "0" and to ON to set it to "1."

#### **Note**

This number is factory-preset to [000].

**[Right side]**

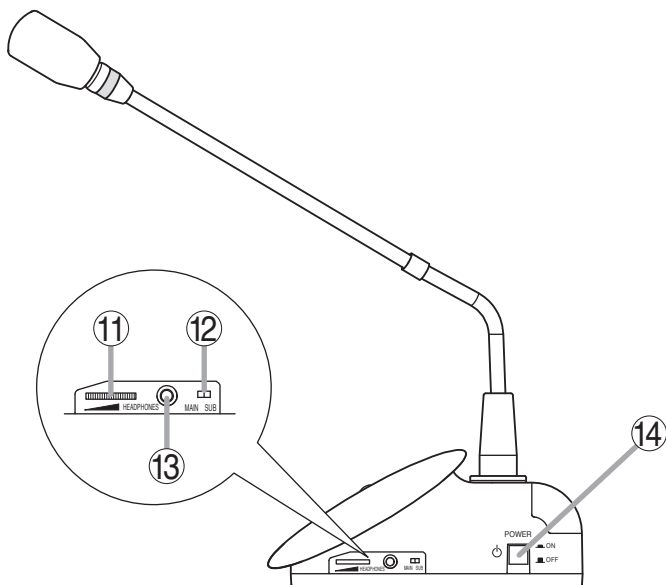

**11. Monitor volume control**

Adjusts the output volume of the monitor speaker and right-side headphone output.

**12. Monitor selector switch (TS-902 only)**

Selects either Base Language or Translation Language for the source to be output to the monitor speaker and headphone.

**13. Headphone jack**

Connect headphones to this jack (mini-jack). Connecting the headphone cuts off the output from the monitor speaker. (Refer to the table below.)

Model	Output signal
TS-902	Base language or Translation language <b>Note:</b> Switchable by the Monitor selector switch (12).
TS-802	Base language

**Note**

A headphone jack is located on both the left and right side panels.

**14. Power switch**

Press this switch to switch on the power.

To switch off the power, press this switch again.

**[Left side]**

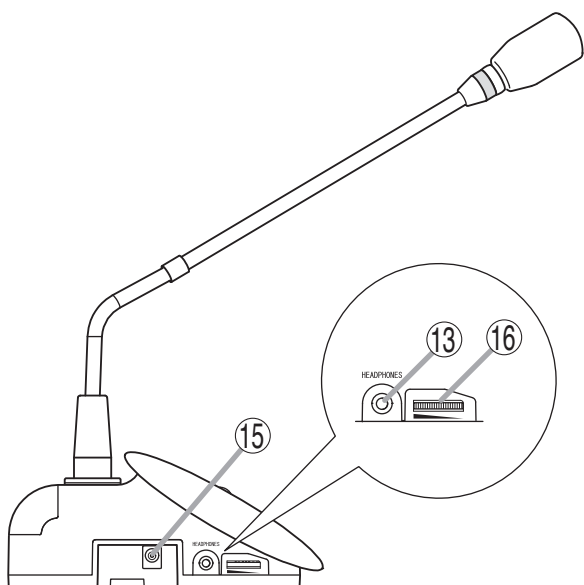

**15. DC inlet**

Connect the dedicated AD-0910 AC Adapter to this terminal.

**16. Headphone volume control**

Adjusts the output volume of the left-side headphone output.



## 4.5. Wired Delegate Units TS-912 and TS-812

[TS-912 Top]

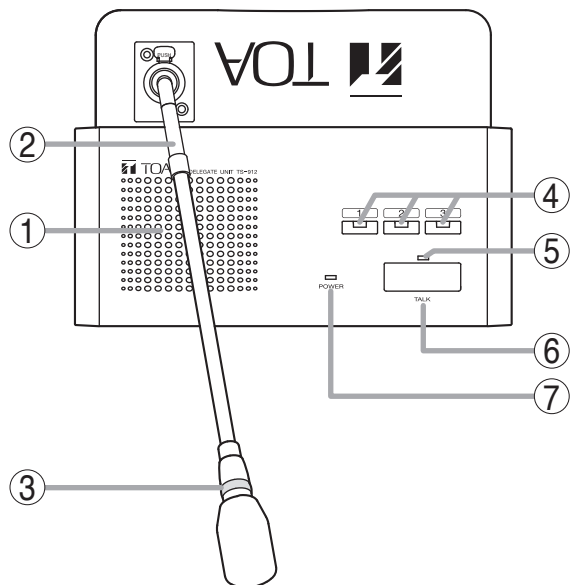

[TS-812 Top]

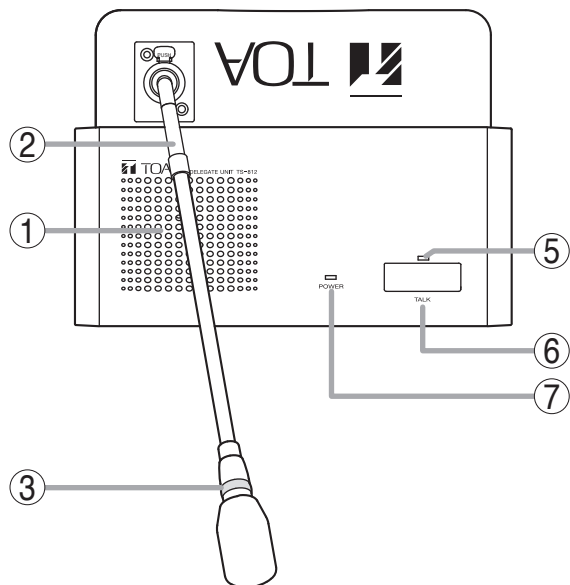

**Note**  
No microphone is supplied with the TS-912/812.

### 1. Monitor speaker

Speech signals from other Conference units and other audio signals from the Central unit are output from this speaker. (Refer to the table below.)

Model	Output signal
TS-912	Base language or Translation language <b>Note:</b> Switchable by the Monitor selector switch (11).
TS-812	Base language

Use the right-side Monitor Volume Control (9) to adjust the volume. No sound is output from the speaker of the unit in use while speaking.

### 2. Microphone

Use either the TS-903 (Standard) or TS-904 (Long) dedicated microphone.

### 3. Microphone in-use indicator

Lights when the microphone is turned on (for speech).

### 4. Voting keys (TS-912 only)

Use these keys to start, end, and cast voting. The voting status indicator is provided on each key.

### 5. Speech indicator

Remains lit while the microphone is in use (during speech). The indicator flashes when the unit is out of the communications service area.

### 6. Talk key

When this key is pressed, both the Microphone In-Use indicator (3) and the Speech indicator (5) light, and the microphone turns on. Pressing this key again turns off both indicators and the microphone.

### 7. Power indicator

Lights when power is supplied from the TS-910 Central unit via the TS-918 Expansion unit.

**[Bottom]**

Remove the cover on the bottom side of the unit to expose its setting switches.

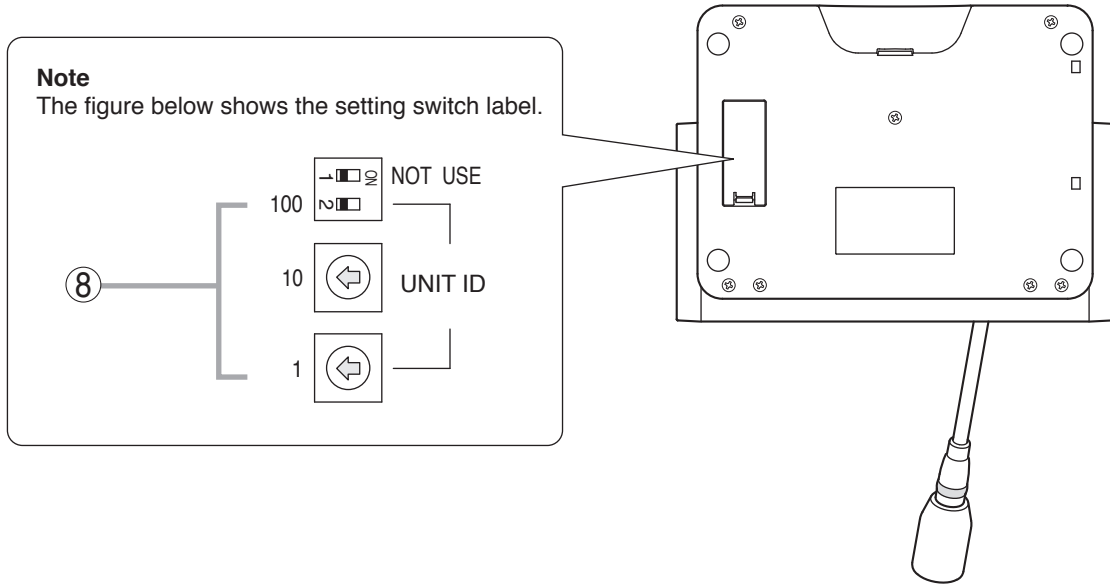

**8. Unit address number setting switch**

Set the unit address number (001 – 192), taking care to ensure that the same number is not duplicated in the system.  
If the number [000] is assigned to a unit, the user of that unit cannot speak. However, the unit can be used for monitoring.

Set a numeral for the one's place and ten's place. Set this switch to OFF to set the hundred's place to "0" and to ON to set it to "1."

**Note**  
This number is factory-preset to [000].

**[Right side]**

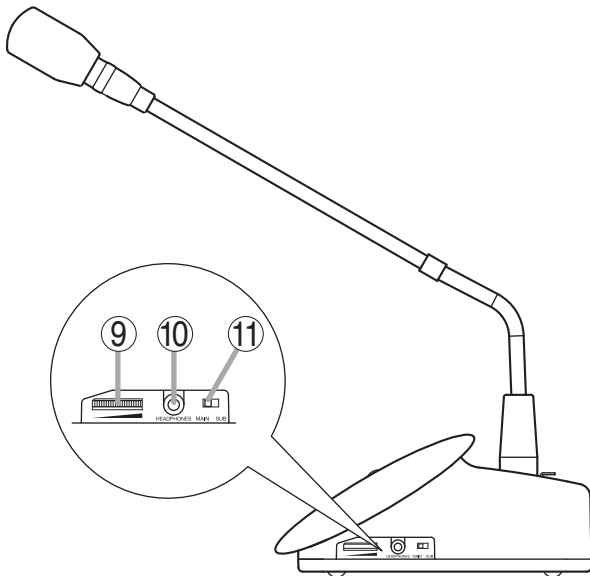

**9. Monitor volume control**

Adjusts the output volume of the monitor speaker and right-side headphone output.

**10. Headphone jack**

Connect headphones to this jack (mini-jack). Connecting the headphone cuts off the output from the monitor speaker. (Refer to the table below.)

Model	Output signal
TS-912	Base language or Translation language <b>Note:</b> Switchable by the Monitor selector switch (11).
TS-812	Base language

**Note**  
A headphone jack is located on both the left and right side panels.

**11. Monitor selector switch (TS-912 only)**

Selects either Base Language or Translation Language for the source to be output to the monitor speaker and headphone.

**[Left side]**

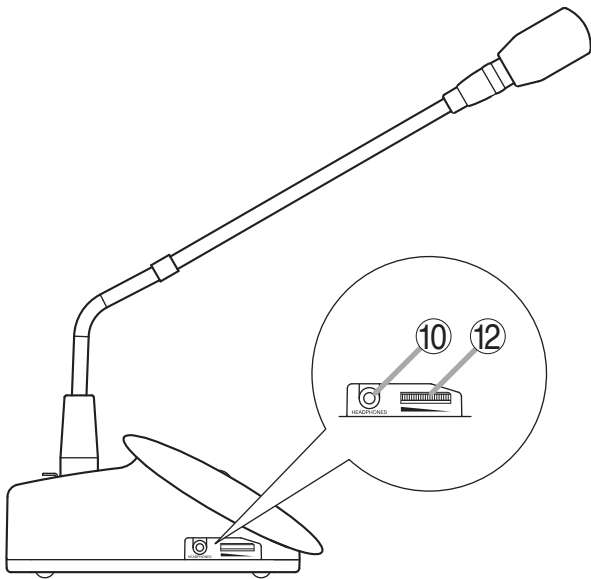

**12. Headphone volume control**

Adjusts the output volume of the left-side headphone output.

**[Rear]**

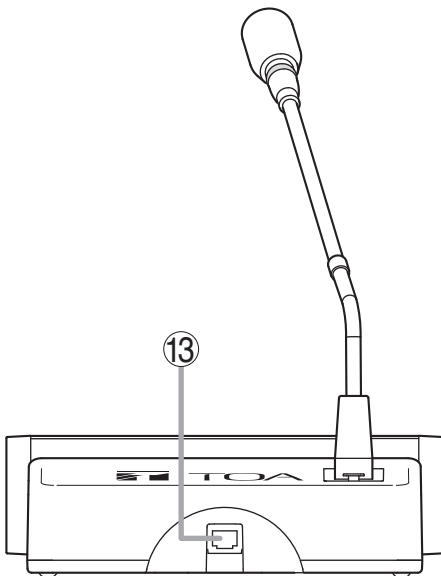

**13. Communication cable connection terminal**

Connects to the TS-919B4 or TS-919B1 Bridge unit with a CAT-5 LAN cable.

## 4.6. Expansion Unit TS-918

[Front]

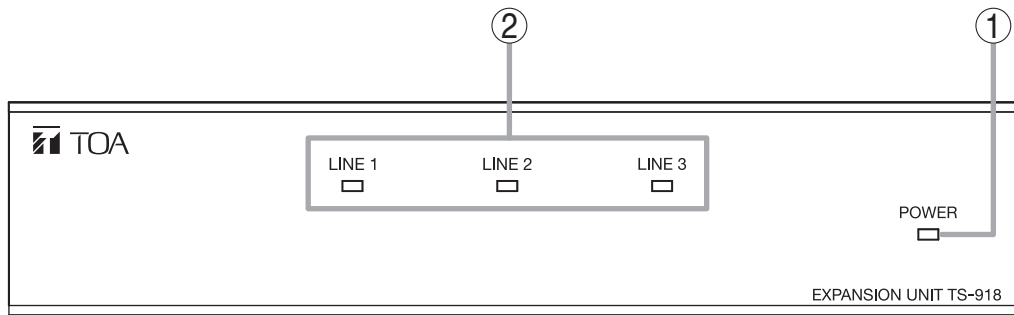

### 1. Power indicator

Lights when connecting the supplied AC adapter to the DC inlet (5).

### 2. Connection status indicators

The corresponding LINE indicator lights when the TS-919B4 or TS-919B1 Bridge unit is connected to the Bridge unit connection terminal (6) and power is supplied to it.

[Rear]

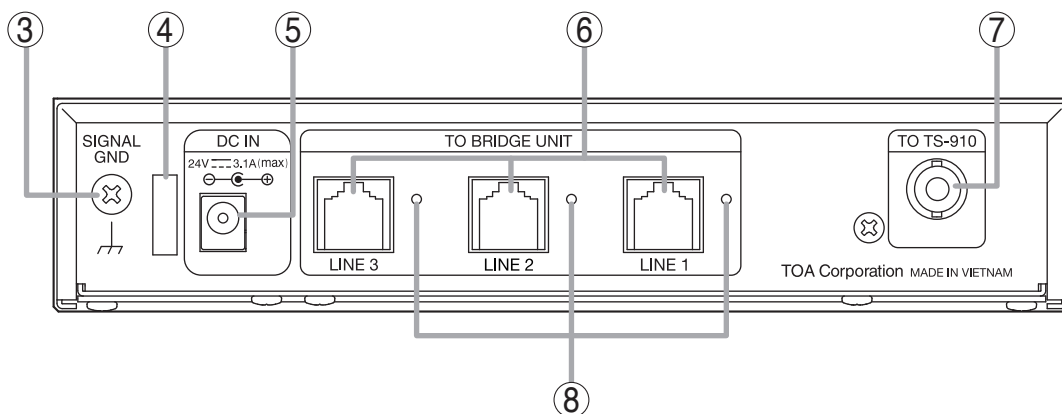

### 3. Functional earth terminal

Hum noise may be generated when external equipment is connected to the unit. Connecting this terminal to the functional earth terminal of the external equipment may reduce the hum noise.

**Note:** This terminal is not for protective earth.

### 4. Cable clip

Run the AC adapter cable through this clip to prevent its plug from being removed from the DC inlet.

### 5. DC inlet

Connect the supplied AC adapter to this terminal.

### 6. Bridge unit connection terminals

Connect the TS-919B4 or TS-99B1 Bridge unit to this terminal with a CAT-5 LAN cable.

### 7. Central unit connection terminal

Connect the TS-910 Central unit, or YW-1022 or YW-1024 Distributor to this terminal with a coaxial cable.

### 8. Connection status indicators

The corresponding LINE indicator lights when the TS-919B4 or TS-919B1 Bridge unit is connected to the Bridge unit connection terminal (6) and power is supplied to it.

### 4.7. Bridge Unit (4-Conference unit connection type) TS-919B4

[Front]

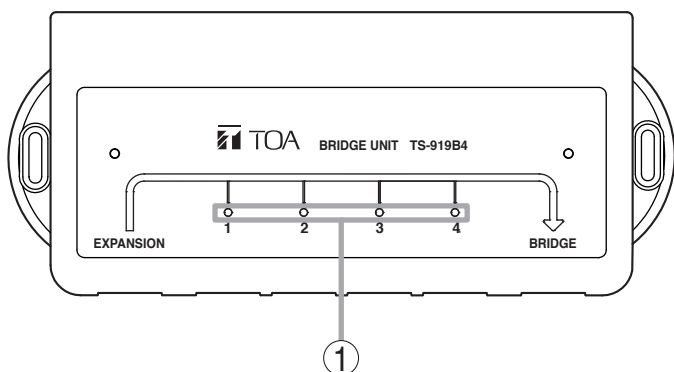

**1. Connection status indicators**

The corresponding LINE indicator lights when the Wired Conference unit is connected to the Conference unit connection terminal (3) and power is supplied to it.

[Bottom]

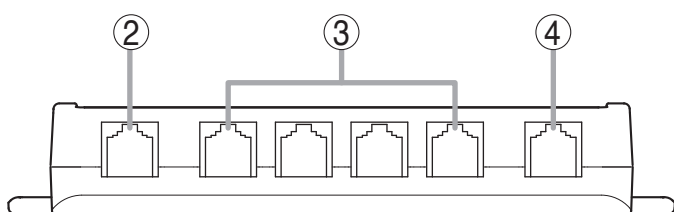

**2. Communication cable connection terminal (Expansion unit side)**

Connects to the TS-918 Expansion unit, or TS-919B4 or TS-919B1 Bridge unit.

**3. Conference unit connection terminals**

Connect to the Wired Conference units.

**4. Communication cable connection terminal (Bridge unit side)**

Connects to the TS-919B4 or TS-919B1 Bridge unit.

### 4.8. Bridge Unit (1-Conference unit connection type) TS-919B1

[Left side]

[Front]

[Right side]

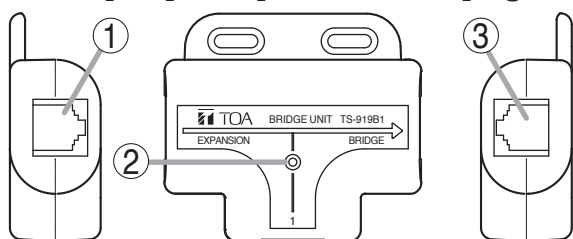

[Bottom]

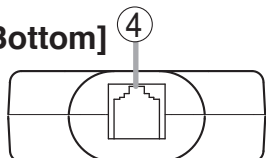

**1. Communication cable connection terminal (Expansion unit side)**

Connects to the TS-918 Expansion unit, or TS-919B4 or TS-919B1 Bridge unit.

**2. Connection status indicator**

Lights when the Wired Conference unit is connected to the Conference unit connection terminal (4) and power is supplied to it.

**3. Communication cable connection terminal (Bridge unit side)**

Connects to the TS-919B4 or TS-919B1 Bridge unit.

**4. Conference unit connection terminal**

Connects to the Wired Conference unit.

# 5. SYSTEM CONNECTION EXAMPLES

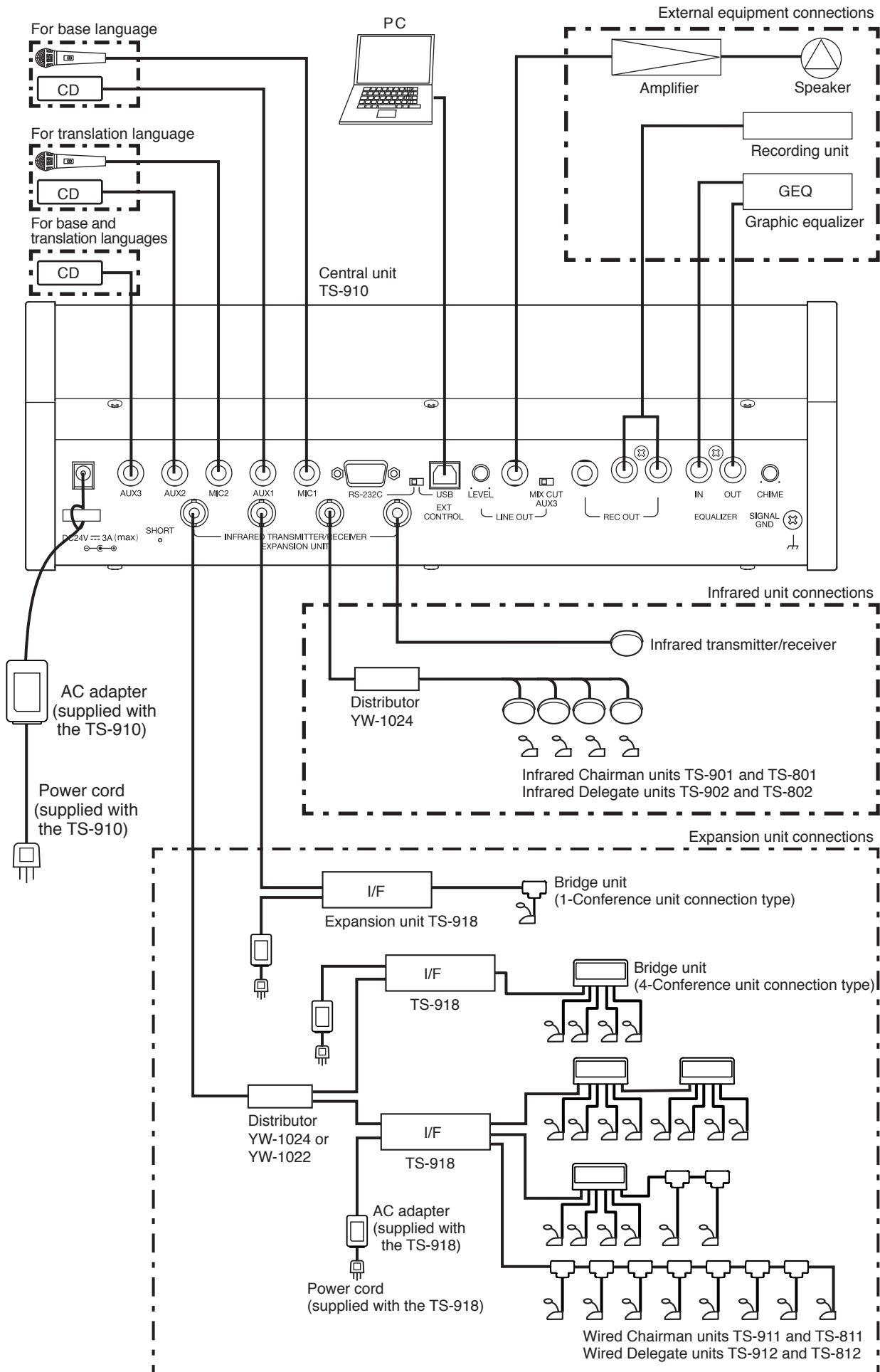

## 6. INFRARED TRANSMITTER/RECEIVER INSTALLATION AND CONNECTIONS

### 6.1. Notes on Installation of the Infrared Transmitter/Receiver Unit

Installing the Infrared Transmitter/Receiver unit in locations exposed to sunlight or in proximity to such infrared sources as fluorescent lights could result in system failures or the introduction of noise into the system. Avoid installing the Infrared Transmitter/Receiver unit in close proximity to infrared sources, as instructed below:

#### [Avoid direct sunlight]

- Cover windows with curtains or blinds to shield the unit from direct exposure to sunlight.
- Install the unit at least 2 – 3 meters away from the nearest window.

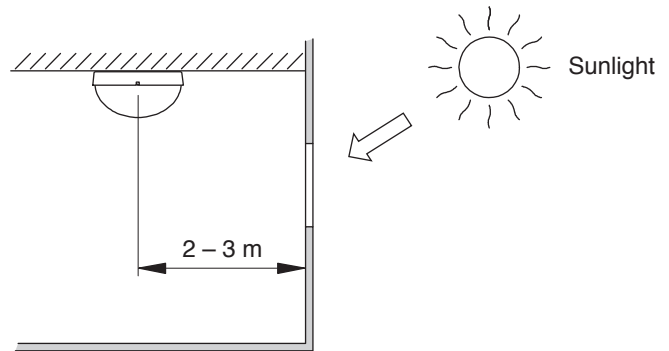

#### [Keep away from fluorescent lights]

Position the unit at least 50 cm away from fluorescent lights.

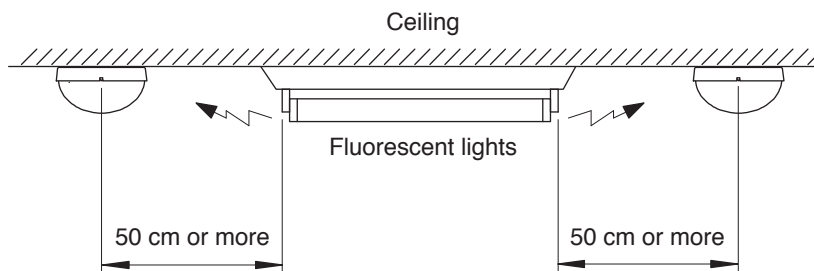

#### [Keep away other infrared light sources]

- Lighting equipment
- LCD projectors, overhead projectors, incandescent lamps, etc.
- Mercury-arc lamps
- Plasma displays
- Remote controllers, infrared microphones, infrared equipment such as infrared LANs.
- Dimmers

## 6.2. Infrared Service Areas

### 6.2.1. Infrared Transmitter/Receiver

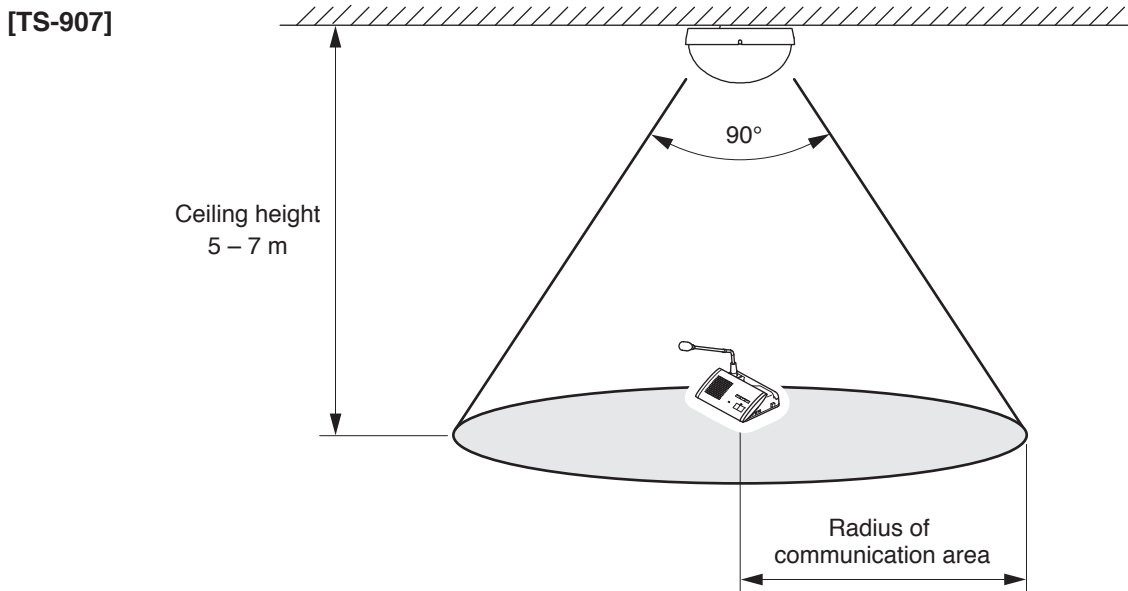
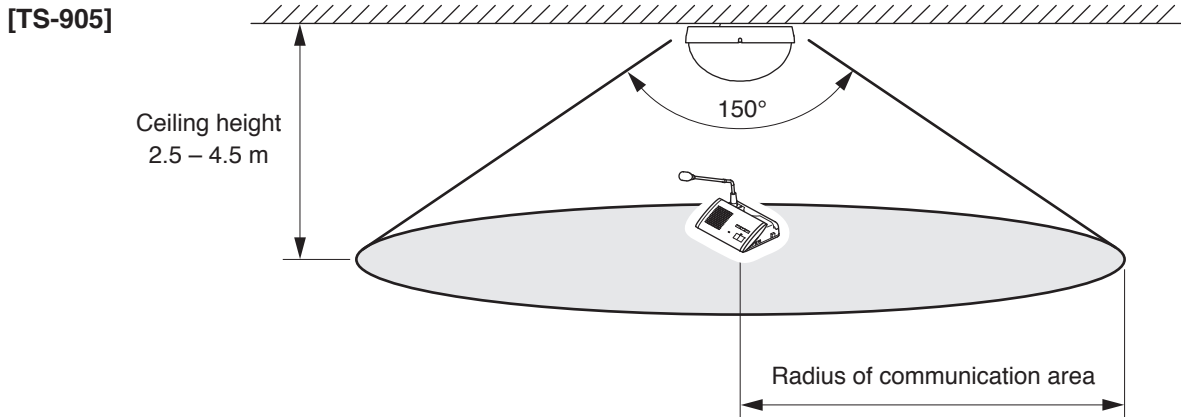

Model	Ceiling height	Radius of communication area
TS-905	2.5 m	Approx. 7.0 m
	3.0 m	
	3.5 m	
	4.0 m	
	4.5 m	
TS-907	5.0 m	Approx. 6.0 m
	5.5 m	
	6.0 m	
	6.5 m	
	7.0 m	

#### Notes

- Infrared signals cannot reach the Infrared Transmitter/Receiver unit if it is hidden behind the user or other objects. Install multiple Transmitter/Receiver units in line-of-sight from all Conference units.
- Install the Infrared Transmitter/Receiver units in such a way that each Conference unit can always communicate with two or more Transmitter/Receiver units. If installed in such a way that communication is only established with one Transmitter/Receiver unit, the infrared signal may be blocked by persons or other objects, possibly causing a momentary loss of signal reception.



## 6.2.2. Infrared Conference Unit

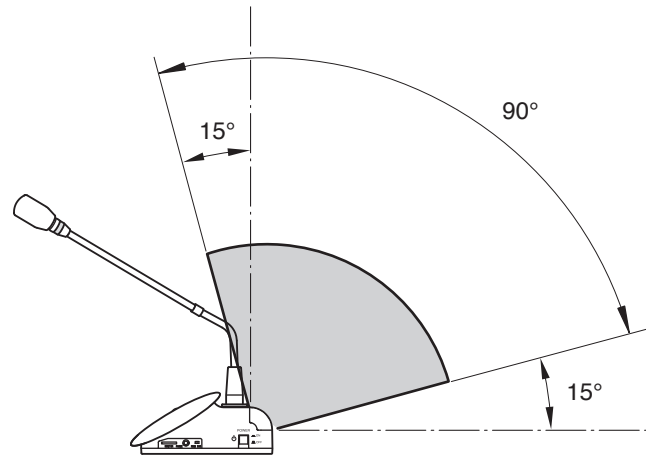
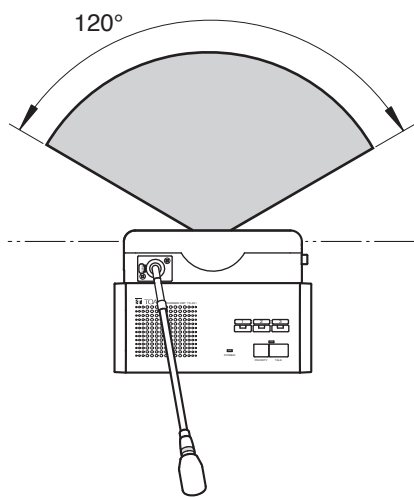
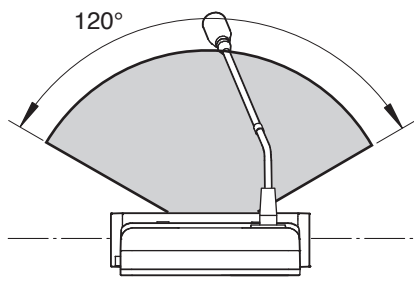

### 6.3. Infrared Transmitter/Receiver Arrangement Examples

The area range that an Infrared Transmitter/Receiver unit covers differs depending on the height from the Infrared Conference units to the ceiling. (Refer to p. 28.)

Arrange the Infrared Transmitter/Receiver units so that all Infrared Conference units are included in the service area.

**Note**

The maximum number of Infrared Transmitter/Receiver units to be installed is 16 when they are all TS-905 units and 12 when they are all TS-907 units. (Also 12 when both models are mixed.)

**[Conference room measuring 30 x 30 meters]**

Arranging the units at intervals as illustrated permits the service area to cover every corner of the room.

**Note**

Determine which to use TS-905 or TS-907 depending on the ceiling height.

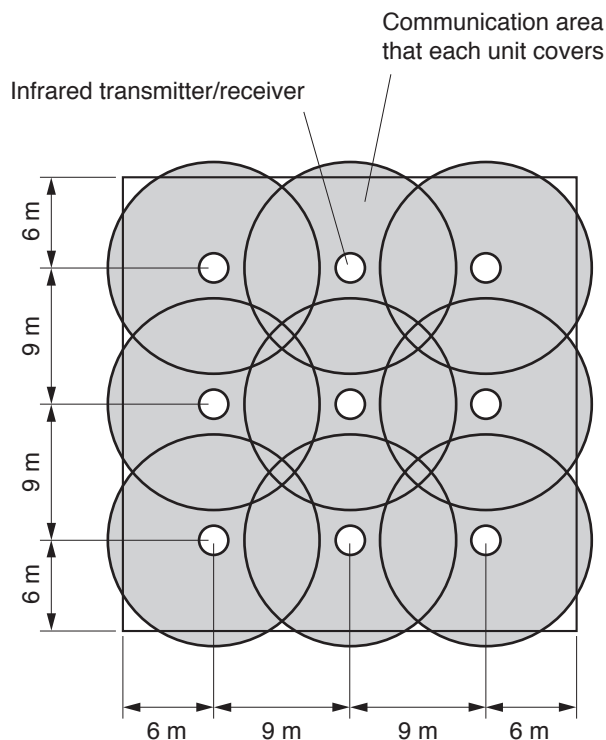

**[Conference room using round tables]**

All Infrared Conference units are arranged around the table, in which case only one Infrared Transmitter/Receiver unit may suffice for complete coverage of conference communications.

However, it is highly recommended that two or more Transmitter/Receiver units be installed in order to avoid accidental interruptions of communications.

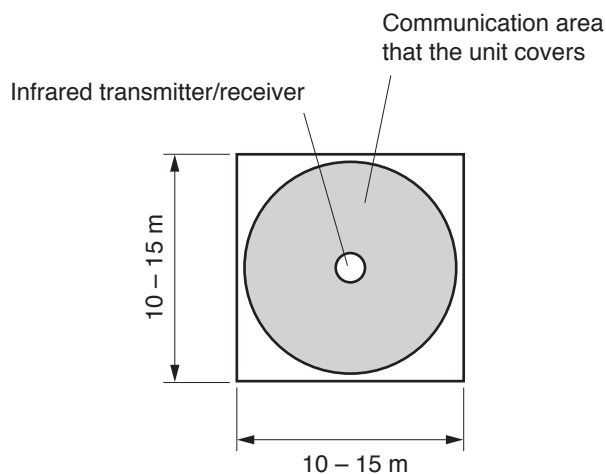

## 6.4. Wiring between the Infrared Transmitter/Receiver Unit and the Central Unit

### 6.4.1. Notes on wiring

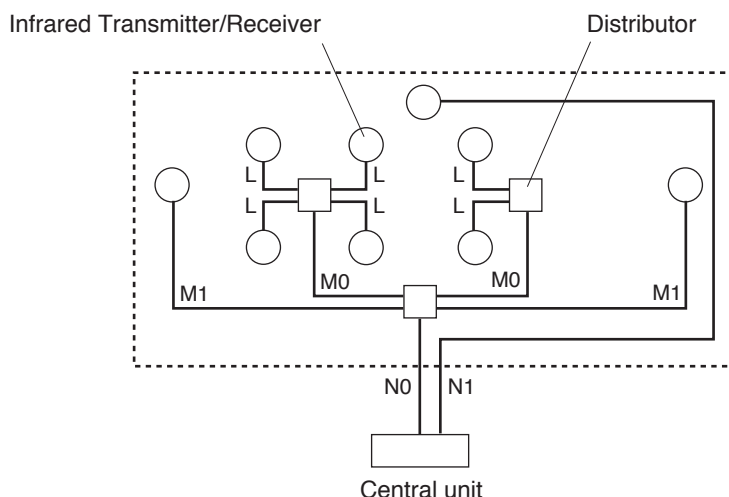

When two or more Infrared Transmitter/Receiver units receive infrared signals from the Infrared Conference units, the signal reception level increases if input signals to each Transmitter/Receiver unit are in phase. If not in phase, the signal reception level may decrease.

- To put signals in phase, ensure that the following cable length between two components are identical.
  - Length between each Infrared Transmitter/Receiver unit and the Central unit:  $L + M0 + N0 = M1 + N0 = N1$
  - Note:** This length must always be the same even if a distributor is included in the wiring.
  - Length between Infrared Transmitter/Receiver unit and distributor: L
  - Length between distributors (where two distributors are connected): M0
  - Length between distributor and Central unit: N0
  - (In the above figure, since there is only one N0 connection, the length need not be matched for the N0 line.)
- The maximum cable length between each Infrared Transmitter/Receiver unit and the Central unit differs depending on the type of coaxial cable to be used. (Refer to p. 54.)  
Take care not to exceed the maximum cable length.

### 6.4.2. Using the Distributor

- The YW-1022 is a 2-branch distributor, and the YW-1024 is a 4-branch distributor. In the case of the YW-1024, its distribution terminals may become idle depending on the Infrared Transmitter/Receiver unit's wiring. However, this presents no problem.
- Avoid connecting more than 2 distributors in series. Connecting 3 or more distributors increases high-frequency signal loss, and could result in system malfunction.
- It is possible to mix Infrared Transmitter/Receiver units not connected to any distributor, those connected to 1 distributor, and those connected to 2 distributors in the same system.
- To avoid an increase in loss, do not perform connections between distribution terminals.

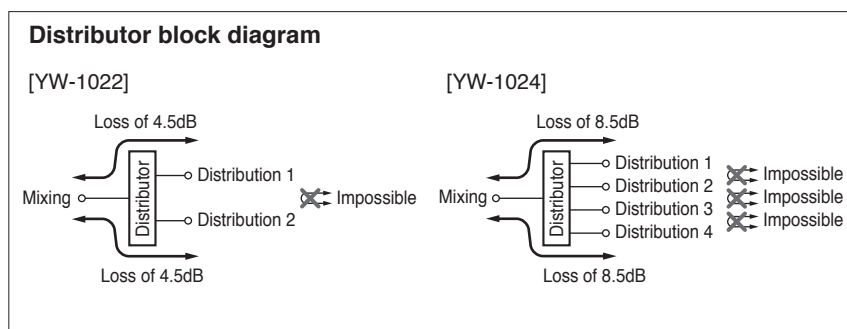

### 6.4.3. Wiring examples

(Example 1)

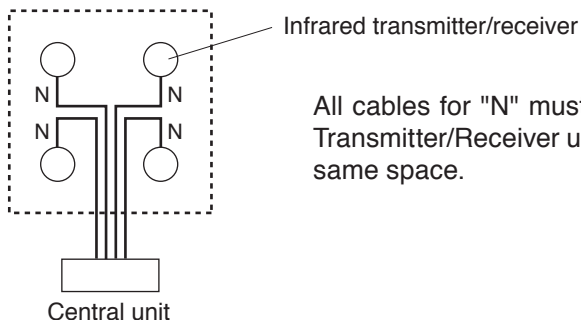

All cables for "N" must be identical in length when the Infrared Transmitter/Receiver unit and the Central unit are installed in the same space.

(Example 2)

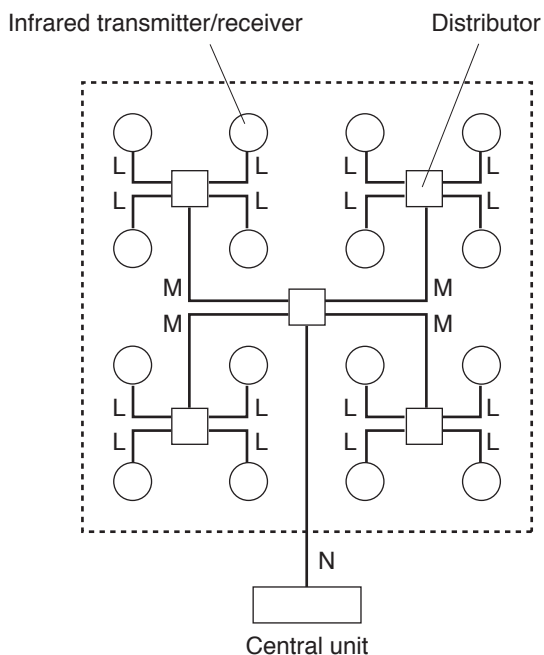

When installing in the same space,

- All "L" cables must be identical in length
- All "M" cables must be identical in length.

**Note**

To facilitate the unification of coaxial cables used in different connections into the same length, it is highly recommended that wiring from the Central unit to the distributor mounted in a ceiling be performed with a single cable. For other ceiling wiring, using pre-cut coaxial cables of a slightly longer length will facilitate making all connections the same length.

(Example 3)

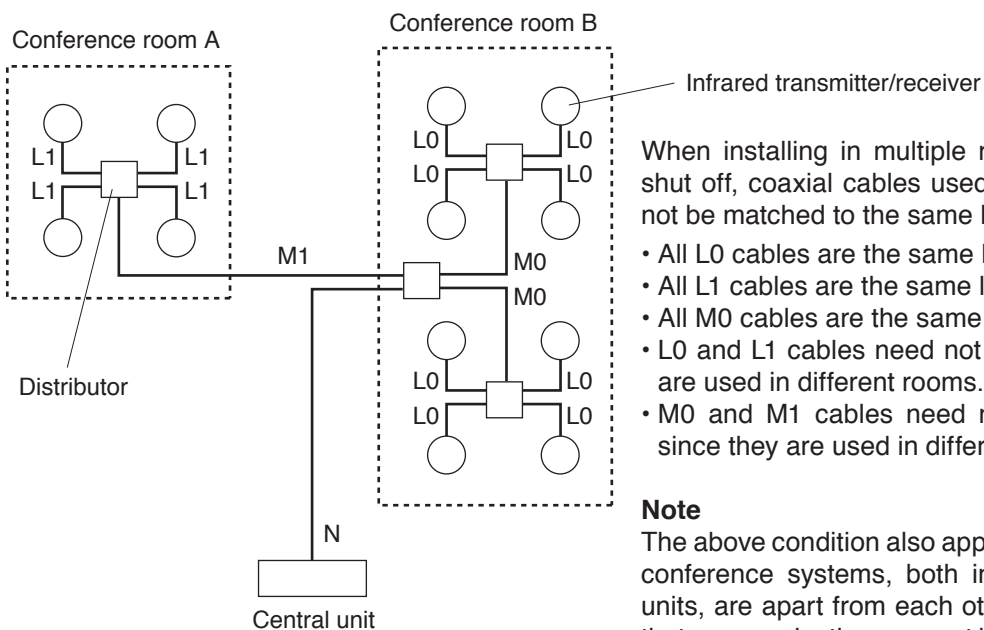

When installing in multiple rooms where the light is shut off, coaxial cables used in different rooms need not be matched to the same length.

- All L0 cables are the same length.
- All L1 cables are the same length.
- All M0 cables are the same length.
- L0 and L1 cables need not be the same, since they are used in different rooms.
- M0 and M1 cables need not be the same length, since they are used in different rooms.

**Note**

The above condition also applies to cases in which two conference systems, both including the Conference units, are apart from each other in the same room so that communications cannot be made between the two systems.



### 6.5.2. Mounting on a microphone stand

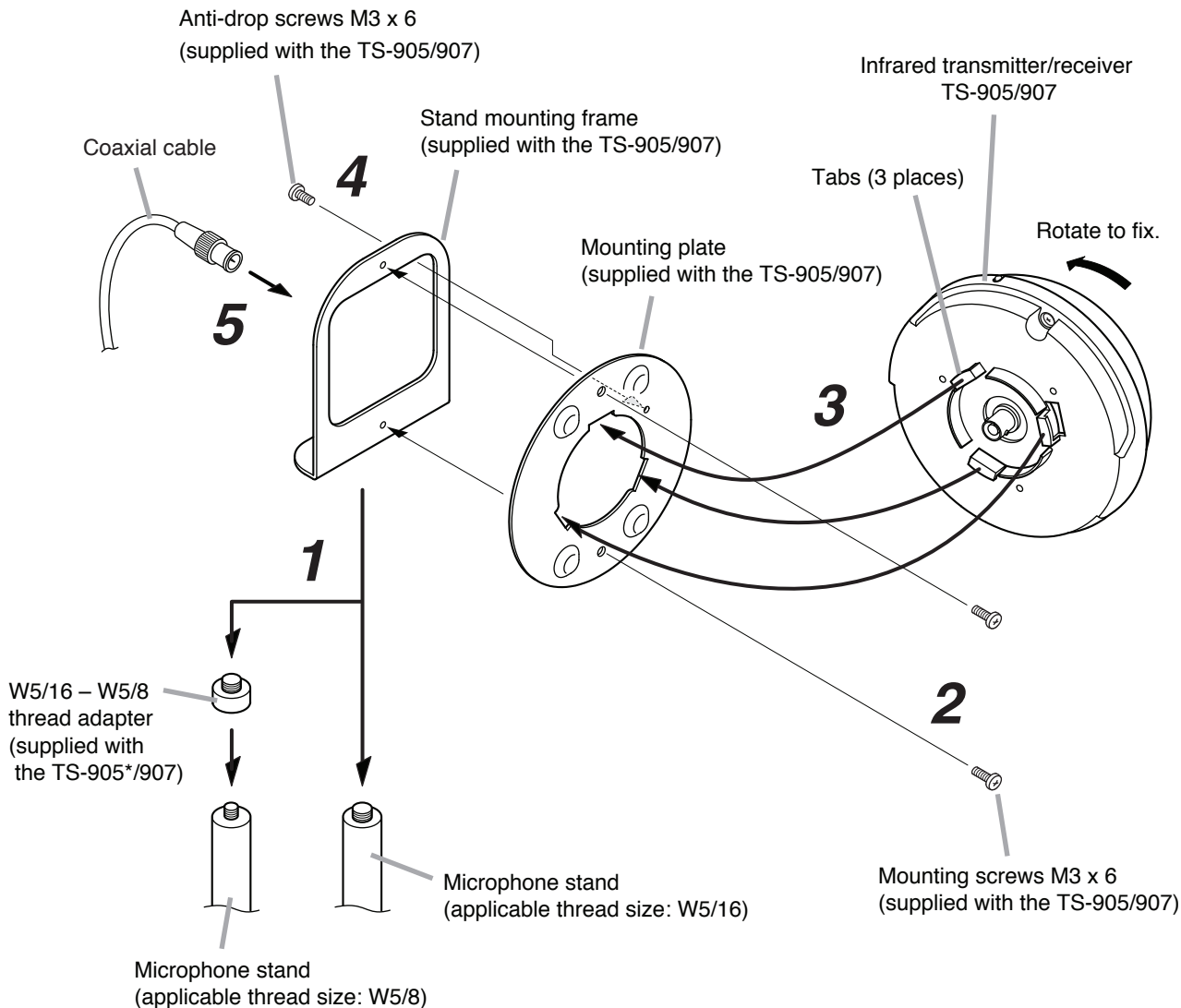

\* Not supplied with the TS-905 CE version.

- Step 1.** Attach the supplied stand mounting frame to the microphone stand.  
Applicable thread size is W 5/16.  
When the stand's thread size is W 5/8, mount the supplied thread adapter onto the microphone stand.
- Step 2.** Fix the supplied mounting plate to the stand mounting frame.  
Use the two supplied M3 x 6 screws for mounting.
- Step 3.** Attach the Infrared Transmitter/Receiver unit to the mounting plate.  
Align the unit's tabs (3 places) with the corresponding notches in the plate, and then rotate the unit clockwise until it stops and fits into place.
- Step 4.** Mount an anti-drop screw to the mounting plate.  
**Note:** The screw tip enters a hole in the unit and prevents its rotation.
- Step 5.** Perform wiring.

## 6.6. Connections between the Infrared Transmitter/Receiver Unit and the Central Unit

### 6.6.1. Connecting

Use the coaxial cable with a BNC connector to connect the Infrared Transmitter/Receiver unit to the Central unit.

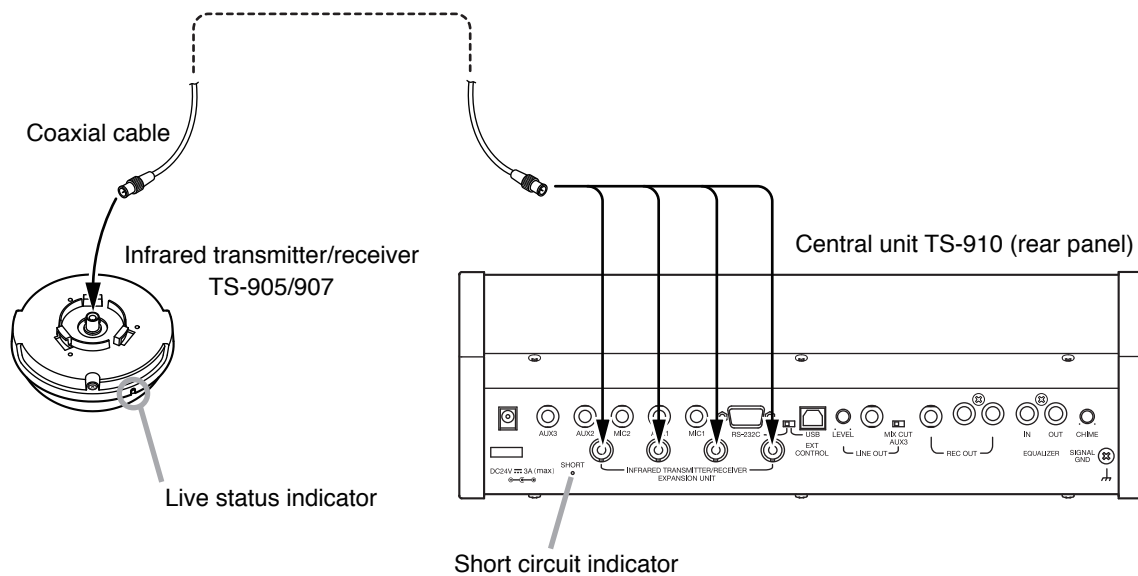

### Notes

- It is recommended that the RG-59/U, RG-6/U, or RG-11/U coaxial cable be used.
- Since the Infrared Transmitter/Receiver unit is equipped with the Live Status indicator, it is possible to confirm whether or not the coaxial cable is correctly connected. (The indicator cannot be used for confirmation of the unit's minimum operating voltage.)  
When the indicator does not light, it can be considered that the coaxial cable is not connected or shorted.
- The Central unit has a Short Circuit indicator on its rear panel and the Central unit's short circuit protection circuit is common to all 4 BNC terminals. If this short circuit indicator lights, locate the shorted point by removing each distributed cord. The indicator also lights when the number of Infrared Transmitter/Receiver units connected in the system exceeds the allowable limit.

### 6.6.2. Coaxial cable processing

Coaxial cable	Applicable BNC plug
RG-59/U	YA-641 (1 piece per package), CC-4900 (10 pieces per package), and CC-4901 (10 pieces per package)
RG-6/U	YA-641 (1 piece per package), CC-4900 (10 pieces per package)
RG-11/U	YA-642 (1 piece per package)

**Note:** Purchase both the coaxial cable and the required BNC plugs separately.

Follow the procedure below to attach the BNC connector to the coaxial cable:

#### Attaching a YA-641 or CC-4901 BNC Plug to the RG-59/U Cable

- Step 1.** Strip the jacket 10 mm from the end of the coaxial cable.
- Step 2.** Slip the tube supplied with the BNC plug over the jacket.
- Step 3.** Unravel the braided shield and turn it back, then peel away the aluminum cladding.
- Step 4.** Strip the dielectric 4 mm from the cable end.
- Step 5.** Disassemble the BNC plug as shown in the figure at right and turn the screw on the plug so that it loosens partially but remains in position.
- Step 6.** Insert the coaxial cable into the clamping fixture.
- Step 7.** Insert the clamping fixture assembly into the plug.
- Step 8.** Tighten the screw and then clamp the plug by tightening the clamping fixture.

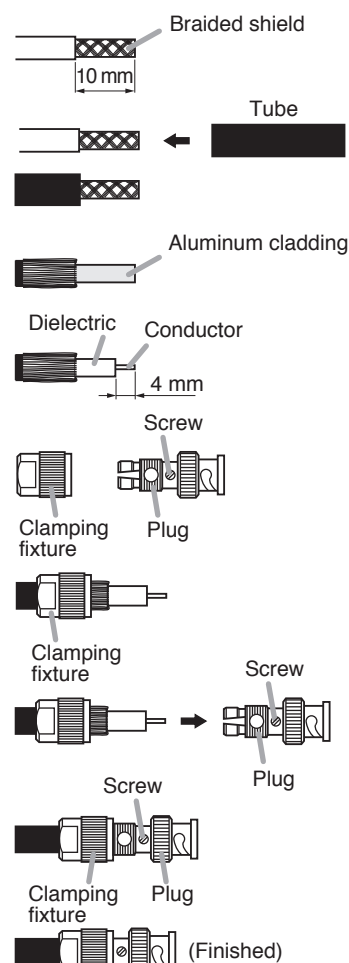

#### Attaching a CC-4900 BNC Plug to the RG-59/U Cable

- Step 1.** Strip the jacket 10 mm from the end of the coaxial cable.
- Step 2.** Slip the tube supplied with the BNC plug over the jacket.
- Step 3.** Unravel the braided shield and turn it back, then peel away the aluminum cladding.
- Step 4.** Strip the dielectric 4 mm from the cable end.
- Step 5.** Disassemble the BNC plug as shown in the figure at right.

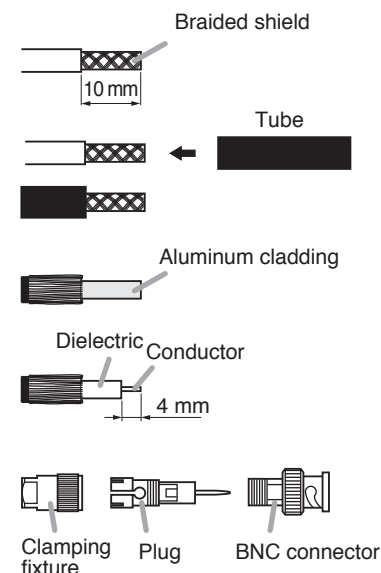



**Step 6.** Insert the coaxial cable into the clamping fixture.

**Step 7.** Insert the clamping fixture assembly into the plug and then solder the conductor.

**Step 8.** Insert the plug into the BNC connector.

**Step 9.** Clamp the connector by tightening the clamping fixture.

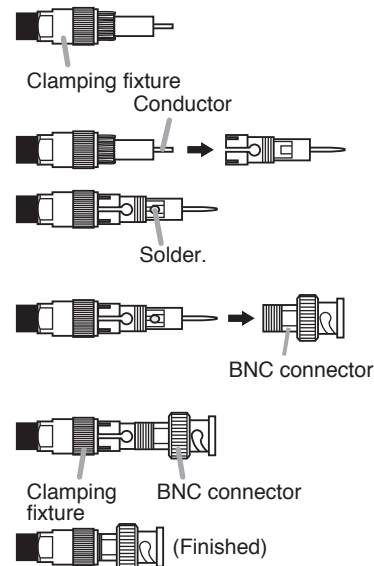

**Attaching a YA-641 BNC Plug to the RG-6/U Cable**

**Step 1.** Strip the jacket 10 mm from the end of the coaxial cable.

**Step 2.** Unravel the braided shield and turn it back, then peel away the aluminum cladding.

**Step 3.** Strip the dielectric 4 mm from the cable end.

**Step 4.** Disassemble the BNC plug as shown in the figure at right and turn the screw on the plug so that it loosens partially but remains in position.

**Step 5.** Insert the coaxial cable into the clamping fixture.

**Step 6.** Insert the clamping fixture assembly into the plug.

**Step 7.** Tighten the screw and then clamp the plug by tightening the clamping fixture.

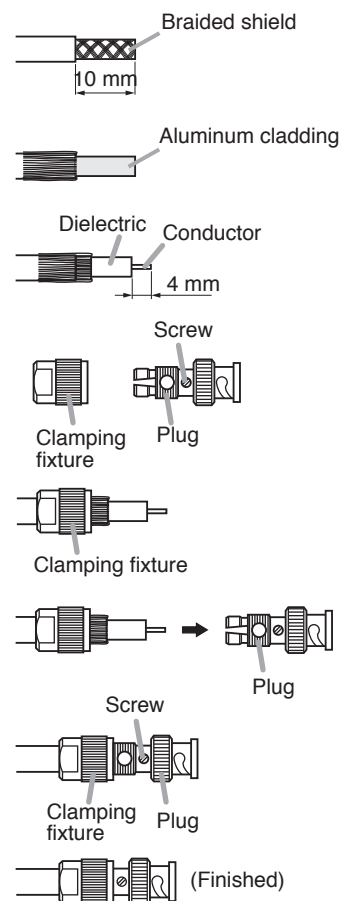

**Attaching a CC-4900 BNC Plug to the RG-6/U Cable**

**Step 1.** Strip the jacket 10 mm from the end of the coaxial cable.

**Step 2.** Unravel the braided shield and turn it back, then peel away the aluminum cladding.

**Step 3.** Strip the dielectric 4 mm from the cable end.

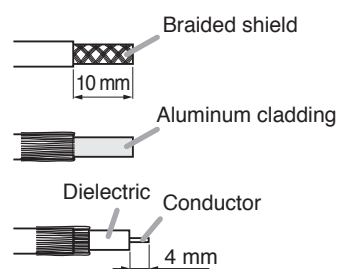

**Step 4.** Disassemble the BNC plug as shown in the figure at right.

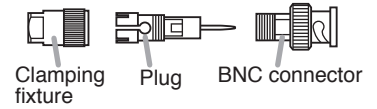

**Step 5.** Insert the coaxial cable into the clamping fixture.

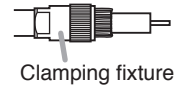

**Step 6.** Insert the clamping fixture assembly into the plug and then solder the conductor.

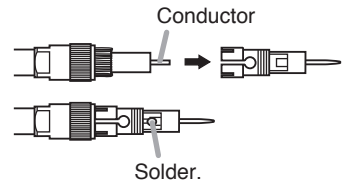

**Step 7.** Insert the plug into the BNC connector.

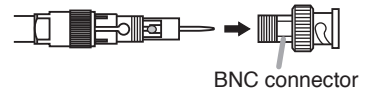

**Step 8.** Clamp the connector by tightening the clamping fixture.

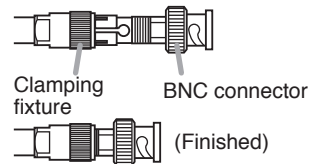

**Attaching a YA-642 BNC Plug to the RG-11/U Cable**

**Step 1.** Disassemble the BNC plug as shown in the figure at right.

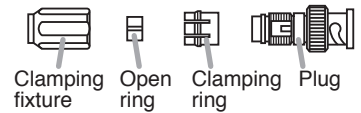

**Step 2.** Strip the jacket 15 mm from the end of the coaxial cable.

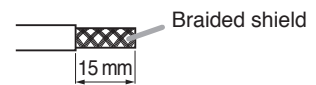

**Step 3.** Insert the coaxial cable into the open ring.



**Step 4.** Unravel the braided shield and turn it back, then peel away the aluminum cladding.



**Step 5.** Strip the dielectric 5 mm from the cable end.

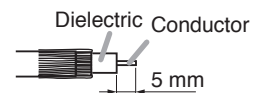

**Step 6.** Insert the coaxial cable into the clamping fixture.

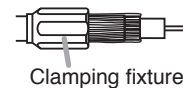

**Step 7.** Attach the clamping ring to the plug.

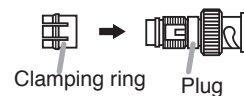

**Step 8.** Insert the clamping fixture assembly into the plug.

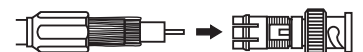

**Step 9.** Solder the conductor to the plug.

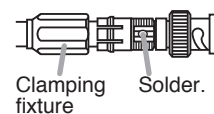

**Step 10.** Clamp the plug by tightening the clamping fixture.



## 7. WIRED CONFERENCE UNIT CONNECTION

When connecting the Wired Conference units to the Central unit, the Expansion unit and the Bridge unit must be installed between them.

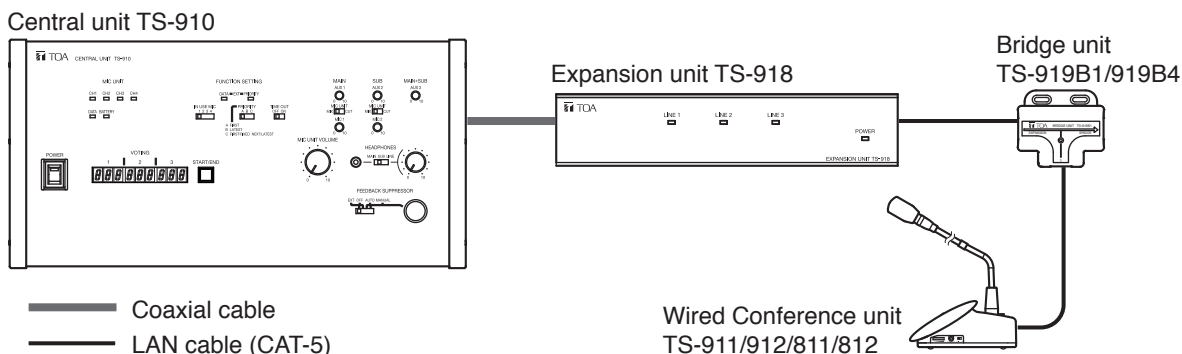

### 7.1. Central Unit and Expansion Unit Connection

Use a coaxial cable to connect the Expansion unit to the Central unit's Infrared Transmitter/Receiver input/output terminal.

One Expansion unit can be connected per Infrared Transmitter/Receiver input/output terminal.

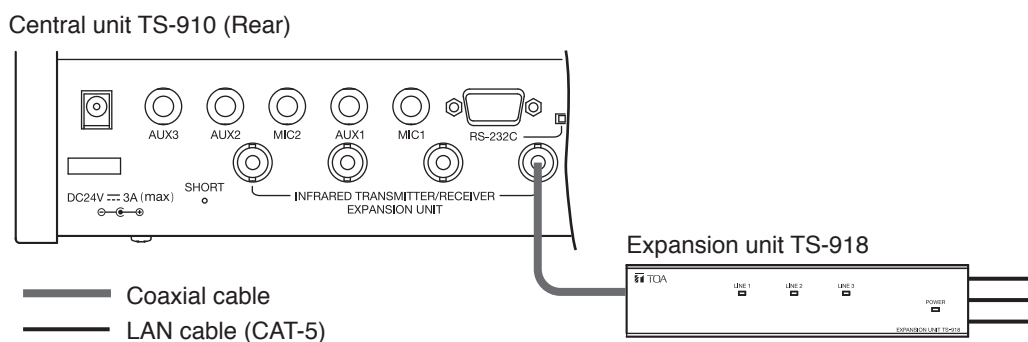

When connecting 2 – 4 Expansion units to a single Infrared Transmitter/Receiver input/output terminal, follow the instructions below.

#### 7.1.1. Connecting 2 Expansion units

Make connections as follows using the YW-1022 Distributor (2-branch distribution).

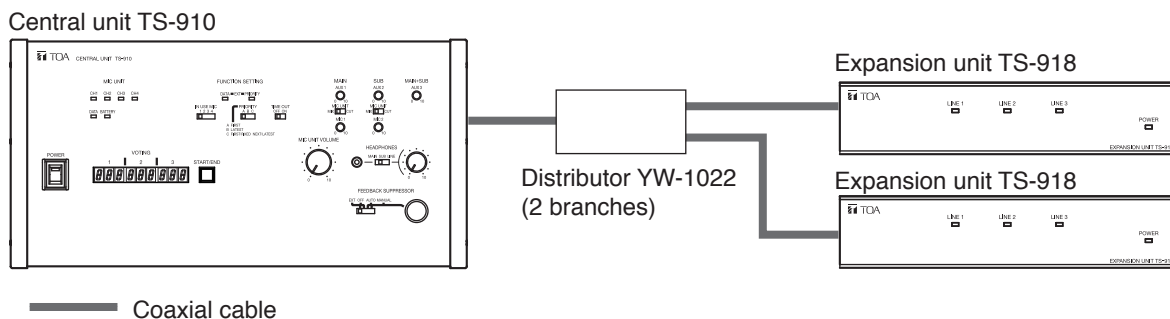

### 7.1.2. Connecting 3 or 4 Expansion units

Use the YW-1024 Distributor (4-branch distribution). Connection of 3 Expansion units will leave one of the four terminals idle, however no problems will result.

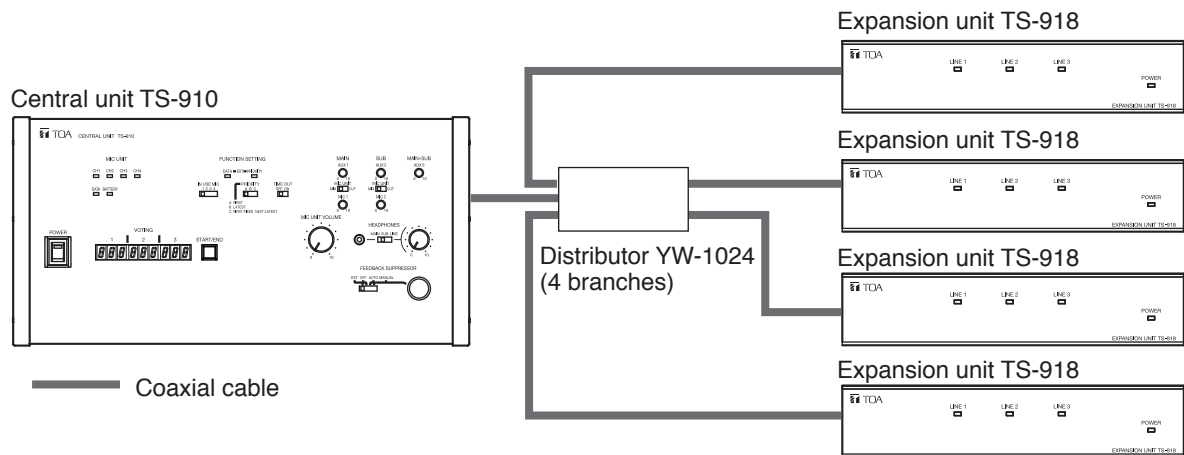

#### Notes

- Only one Distributor at a time can be connected between the Central unit and the Expansion unit. Do not connect Distributors in series to each other.

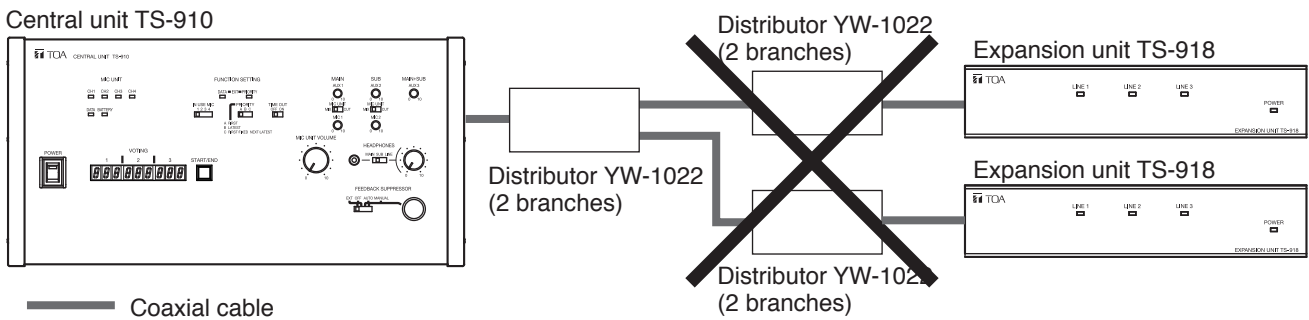

- Connect the Central unit's Infrared Transmitter/Receiver input/output terminal separately to either the Wired Conference unit or the Infrared Conference unit. The Expansion unit and the Infrared Transmitter/Receiver unit cannot be simultaneously connected to the same Distributor.

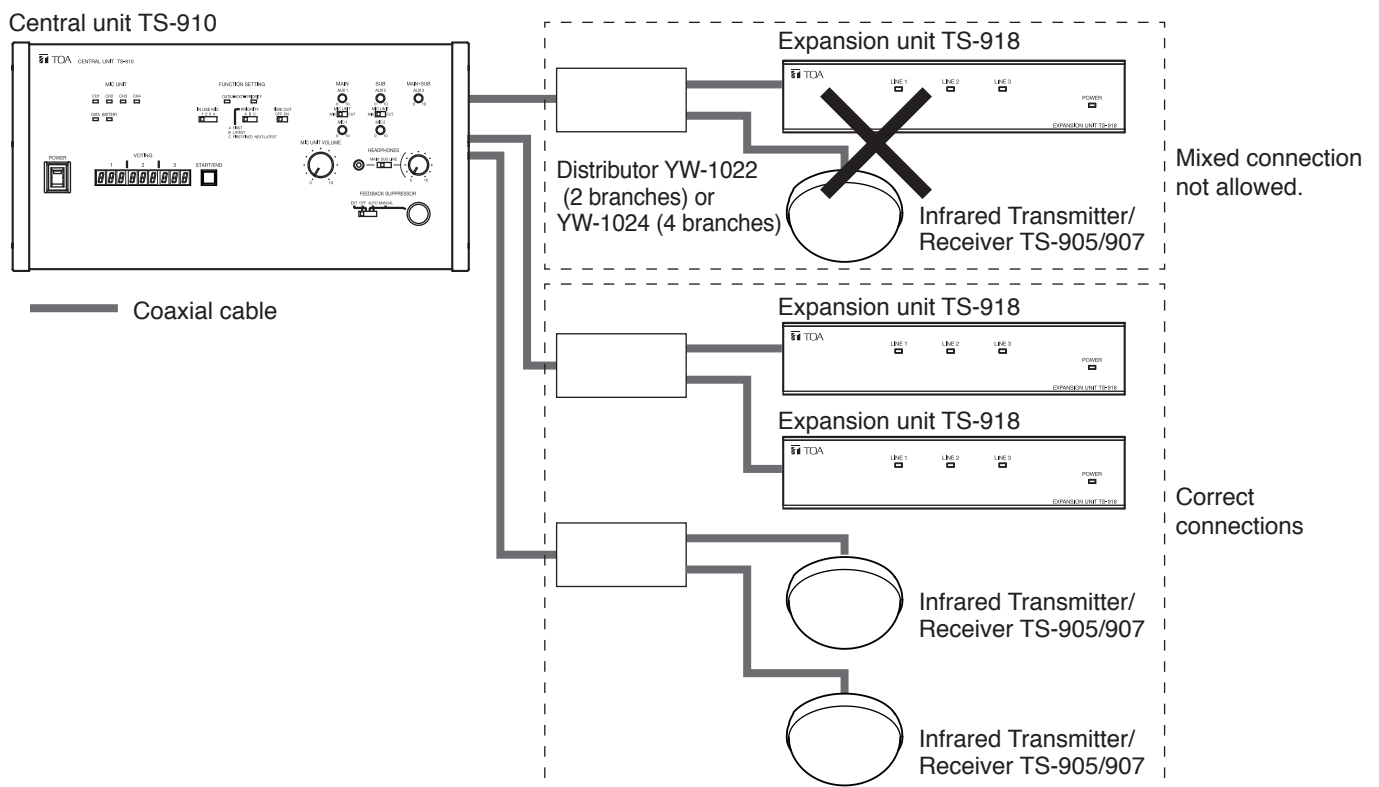

- A system may have Expansion units that both pass through and do not pass through the Distributor.

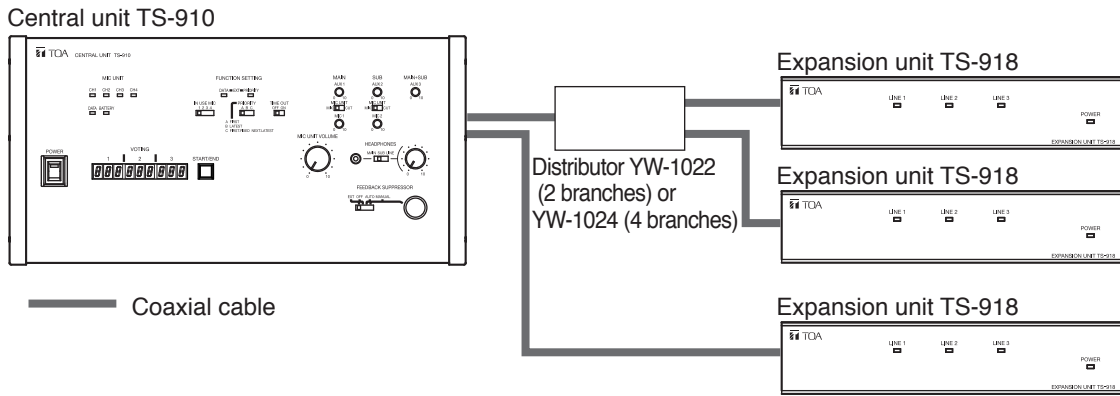

## 7.2. Expansion unit, Bridge Unit, and Wired Conference Unit Connections

When connecting the Expansion unit to the Wired Conference Unit, the Bridge unit must be installed between the two.

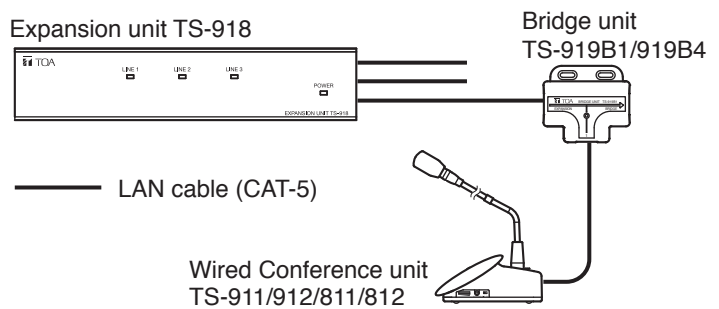

The Expansion unit is equipped with 3 Bridge unit connection terminals. When Bridge units are connected to them, up to 8 Wired Conference units can be connected for each terminal, and up to 24 units per Expansion unit. Two types of Bridge units are available, the 1-Conference unit connection type and the 4-Conference unit connection type.

The number of connection terminals for each type is as follows.

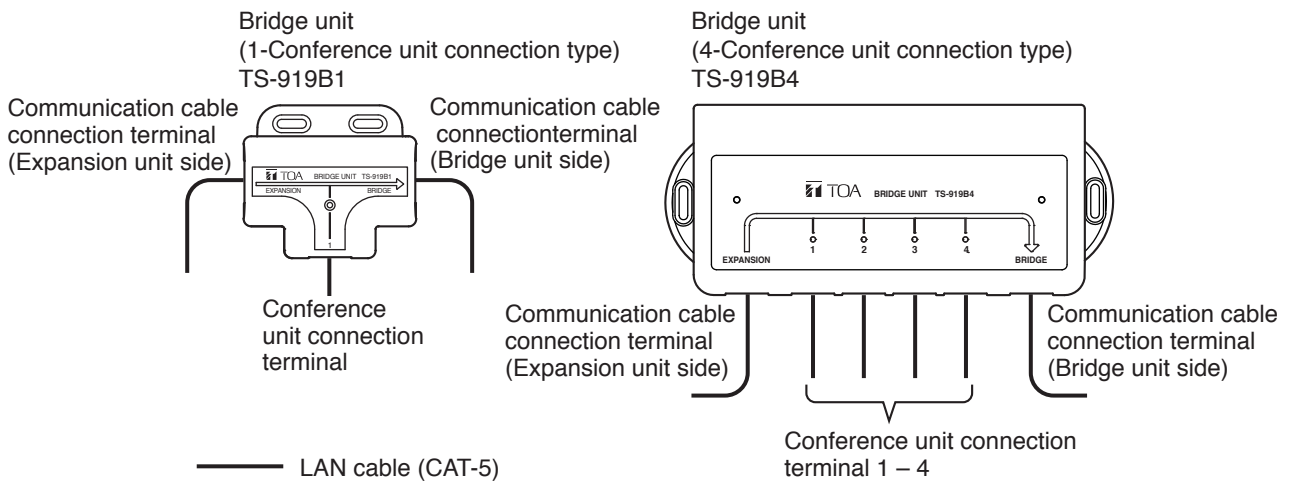

### [Number of Bridge unit's connection terminals]

Model No.	Communication cable connection terminal (Expansion unit side)	Conference unit connection terminal*1	Communication cable connection terminal (Bridge unit side)
TS-919B1	1	1	1*2
TS-919B4	1	4	1*3

\*1 One Wired Conference unit can be connected to each Conference unit connection terminal.

\*2 Either a TS-919B1 or TS-919B4 Bridge unit can be connected. In an exceptional case where 7 Bridge units of 1-Conference unit connection type are connected to one of the Expansion unit's Bridge unit connection terminals, connect the 8th Conference unit, if needed, to the last-connected 1-Conference unit type Bridge unit's communication cable connection terminal (Bridge unit side).

\*3 Can be connected to a TS-919B1 or TS-919B4 Bridge unit. However, the Wired Conference unit cannot be connected.

### 7.2.1. Bridge unit TS-919B1 connection

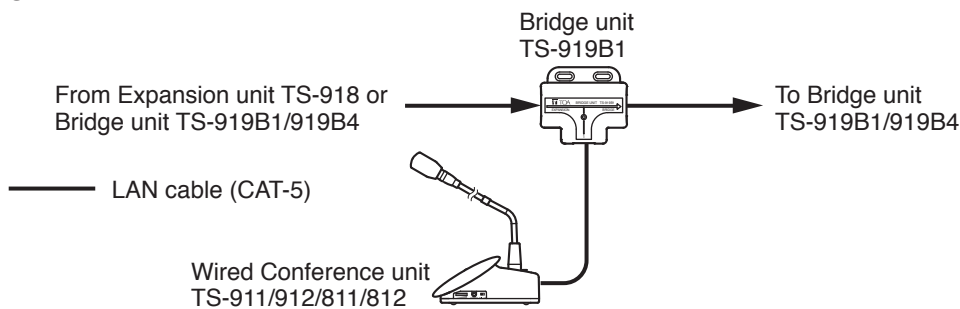

### 7.2.2. Bridge unit TS-919B4 connection

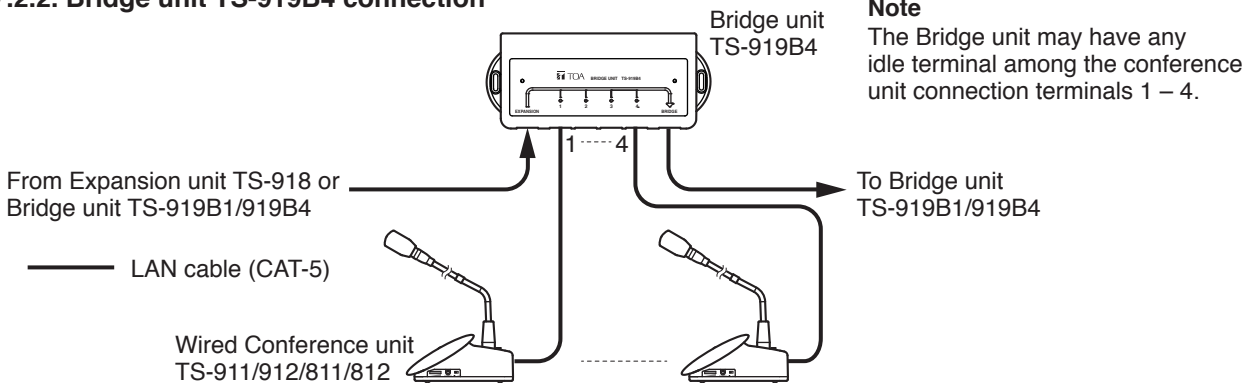

**Note**  
 Properly connect the equipment taking care that the Bridge unit's each terminal is designed to connect the designated equipment.  
 Misconnection may cause the Expansion unit malfunction.

### 7.2.3. Bridge unit connectable to one of the Expansion unit's terminals

When connecting the Bridge unit to the Expansion unit, the number of Bridge units connectable per Bridge unit connection terminal of the Expansion unit differs as shown below depending on the combination of two types of Bridge units.

Combination of Bridge units	Number of connectable units
TS-919B4 only	One or two TS-919B4s
TS-919B4 and TS-919B1 mixed	One TS-919B4 and up to four TS-919B1s
TS-919B1 only	Up to seven TS-919B1s

#### [Connection example]

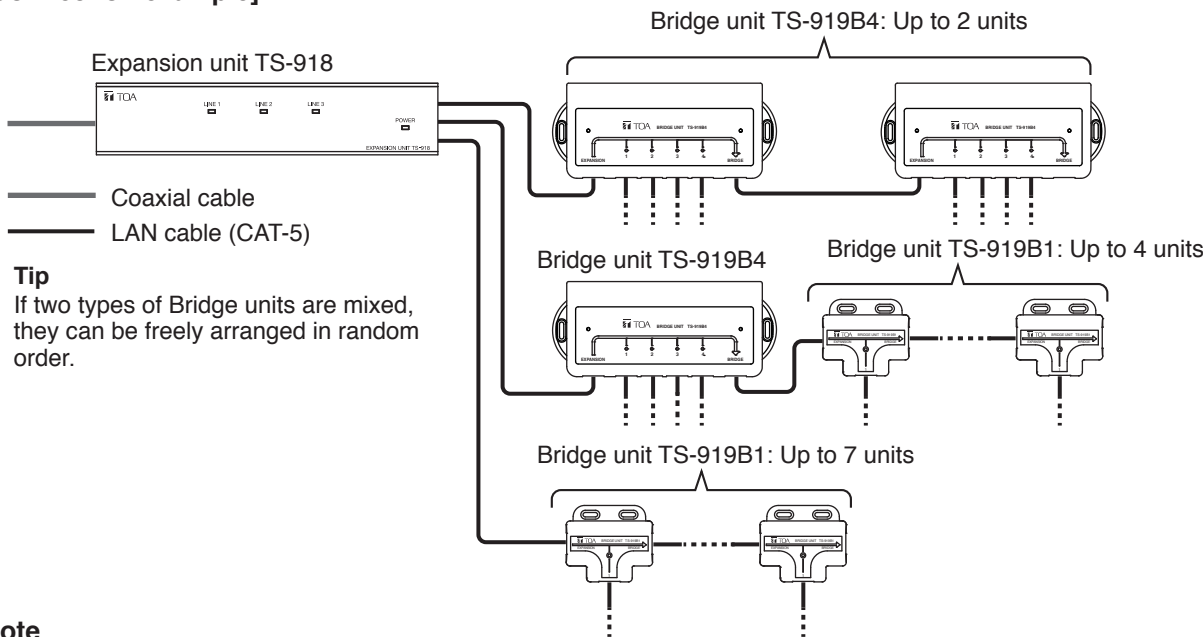

**Tip**  
 If two types of Bridge units are mixed, they can be freely arranged in random order.

**Note**  
 When the units are connected beyond the maximum number of units, this may cause the Conference units to malfunction.

### 7.2.4. Connecting 8 Wired Conference units to one of the Expansion unit's terminals

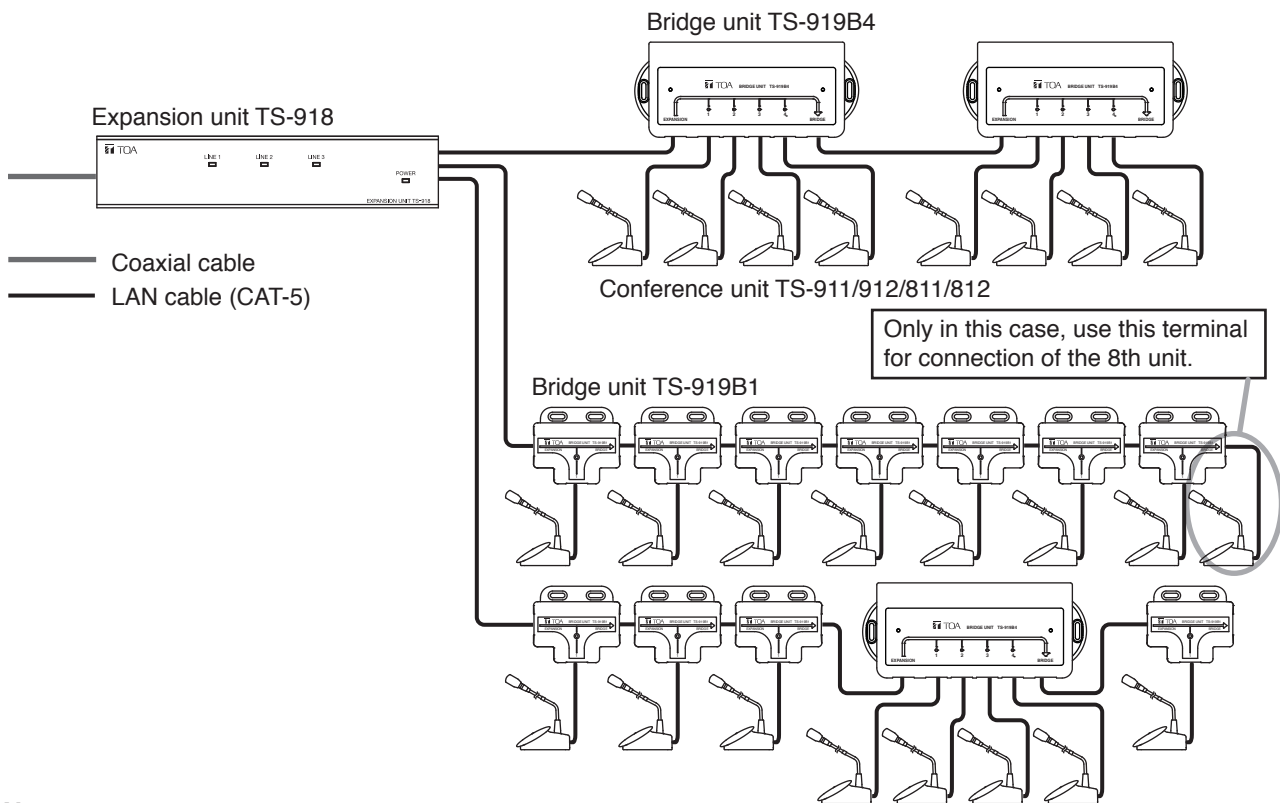

#### Notes

- The Wired Conference units cannot be connected to the TS919B4's Bridge output terminal. (Refer to the example A.)
- When both the TS-919B4 and TS-919B1 are used in the same system, the Conference units cannot be connected to the TS-919B1's Bridge output terminal. (Refer to the examples B and C.)
- Only when all the connected Bridge units are TS-919B1s, up to 7 TS-919B1s can be connected to a single terminal of the Expansion unit. The 8th TS-919B1 cannot be connected. (Refer to the example D.)

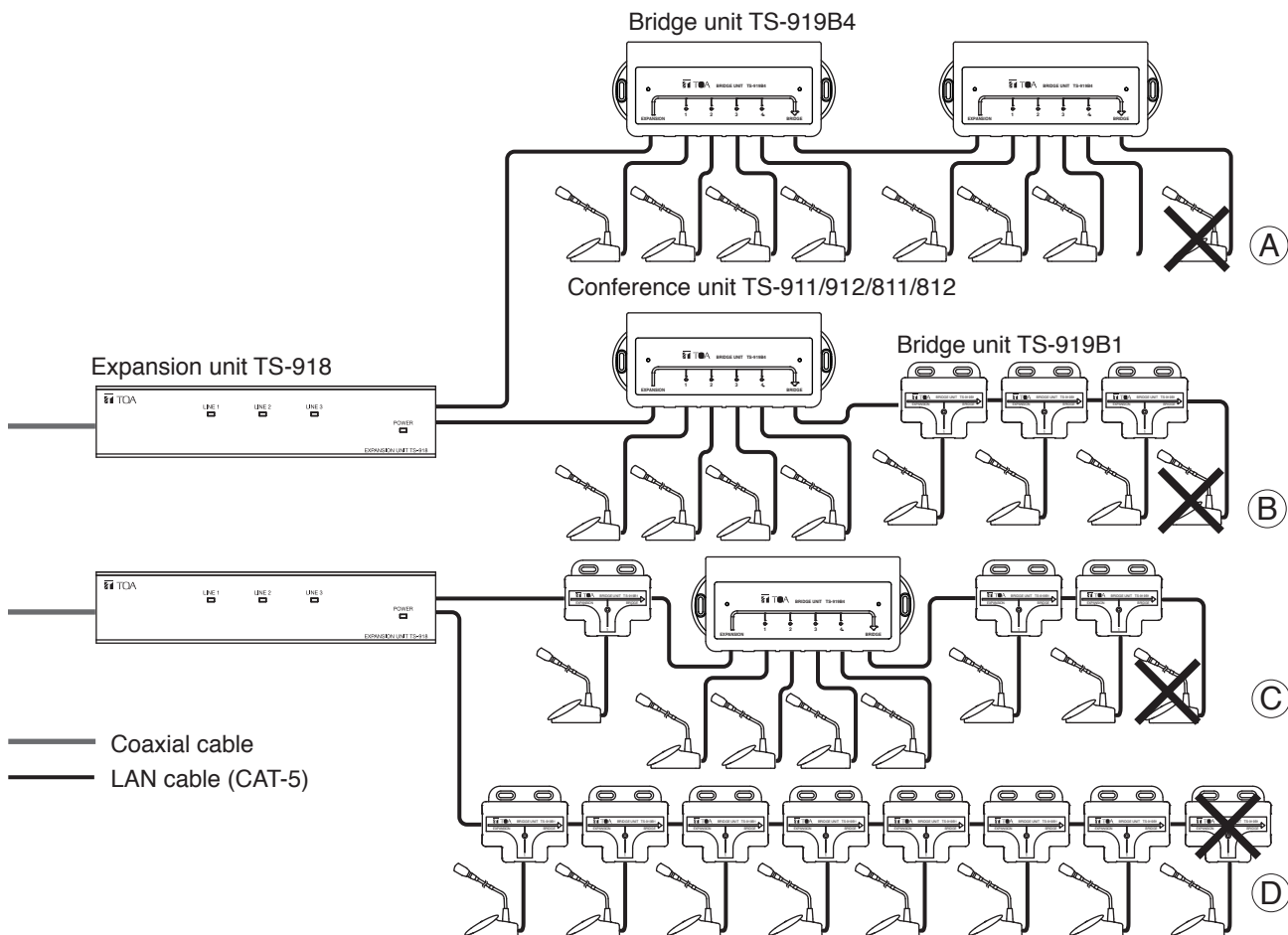

- There is restriction on the number of the Bridge units that can be connected to one of the Expansion unit's Bridge unit connection terminals. (Refer to p. 42.)

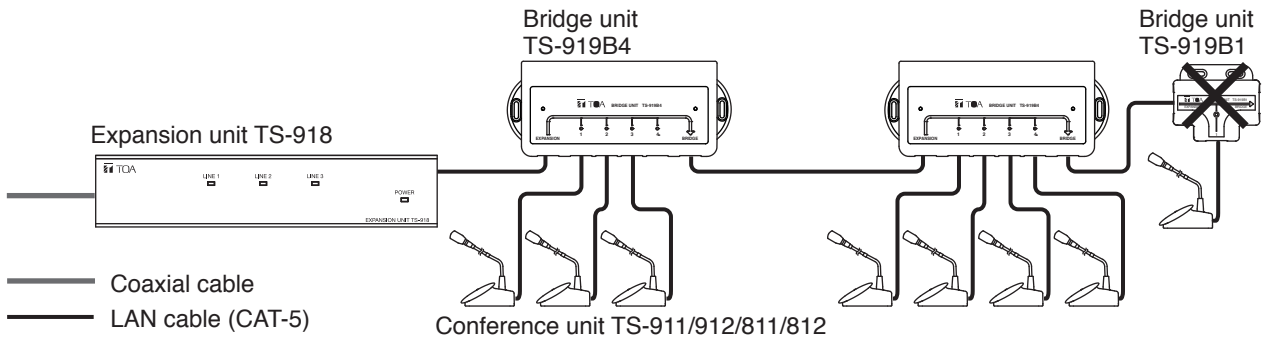

## 7.3. Wiring

### 7.3.1. Type of cable used

Connection	Cable	
Between the Central unit and the Expansion unit	Coaxial cable	Use one of the following types: RG-59/U, RG-6/U, and RG-11/U.
Between the Expansion unit and the Wired Conference units	LAN cable	Use LAN cables that are compatible with UTP Category 5 (straight cable) or that can support transmission speeds exceeding that of Category 5 cable.

#### Note

Cable lengths for the above wiring need not be adjusted as required in the case of the Infrared Transmitter/Receiver unit.

### 7.3.2. Extendable cable distances

The extendable distance differs depending on whether or not a Distributor is used.

#### [When using the Distributor (Maximum cable distance: 100 m)]

Distance between the Central unit and each Wired Conference unit: 100 m\* max.

\* Total distance of coaxial cable and LAN cable.

There is no restriction on the ratio of the cable length between the two.

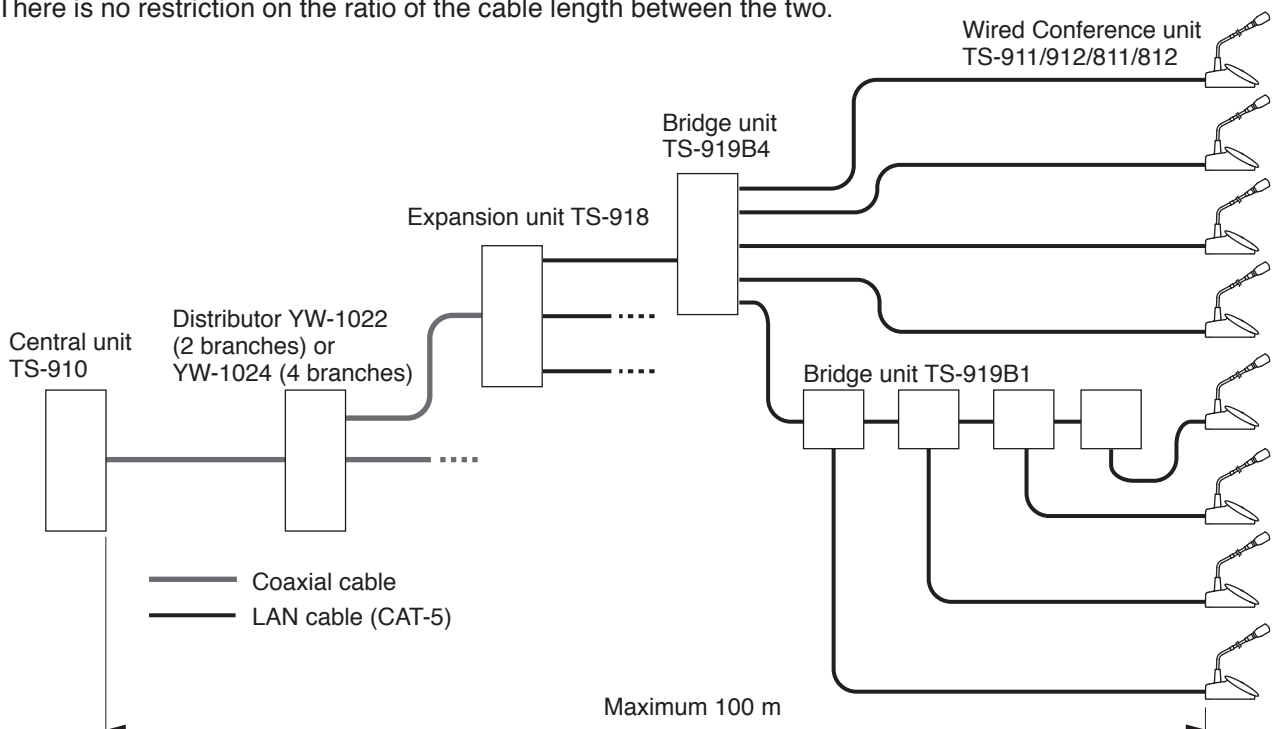



**[When using no Distributor (Maximum cable distance: 200 m)]**

Distance between the Central unit and Expansion unit: 100 m max.  
 Distance between the Expansion unit and each Wired Conference unit: 100 m max.  
 Distance between the Central unit and each Wired Conference unit: 200 m max.

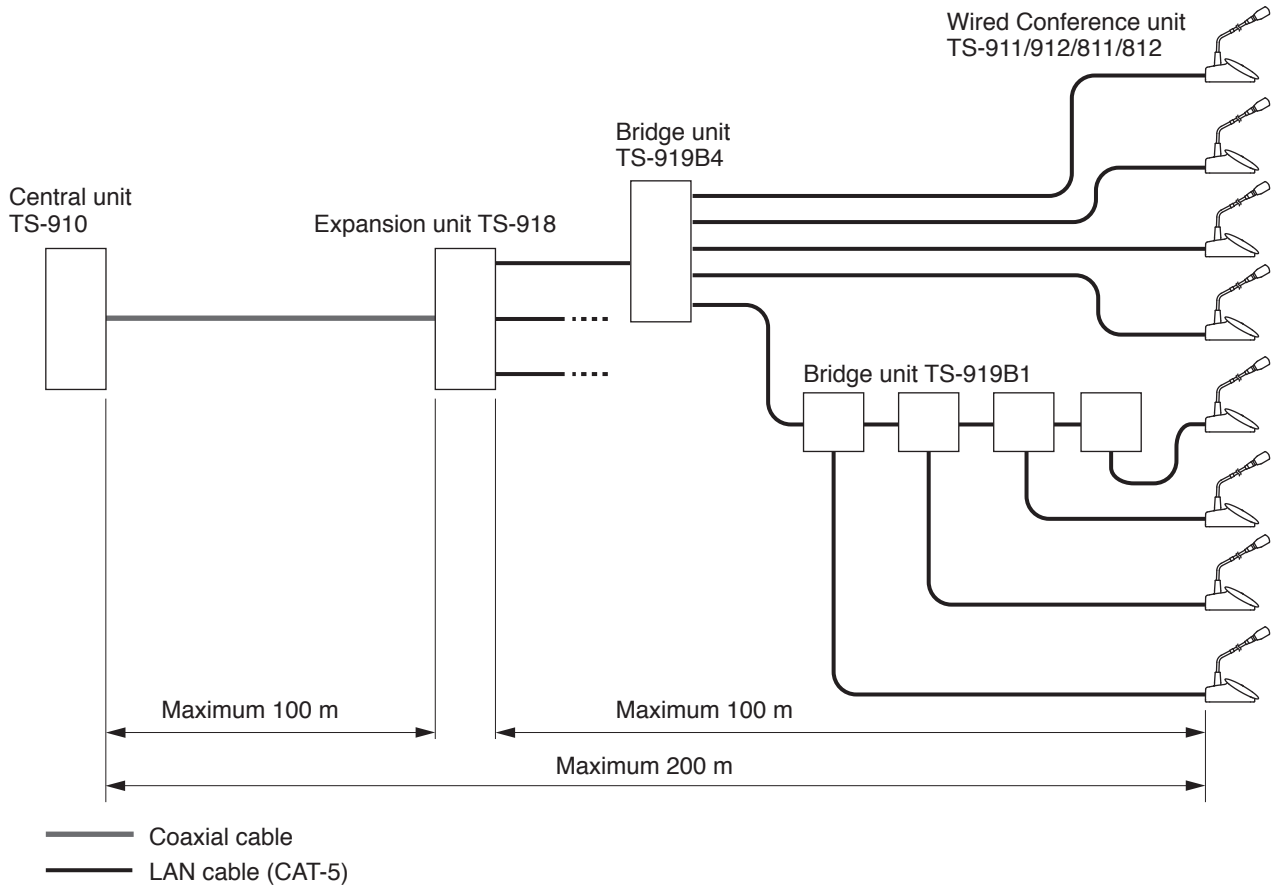

**8. USING WIRED MICROPHONES AND SOUND SOURCE EQUIPMENT**

**8.1. Wired microphone use**

Connect a wired microphone to the Central unit's MIC input and adjust its volume with the corresponding MIC input volume control.

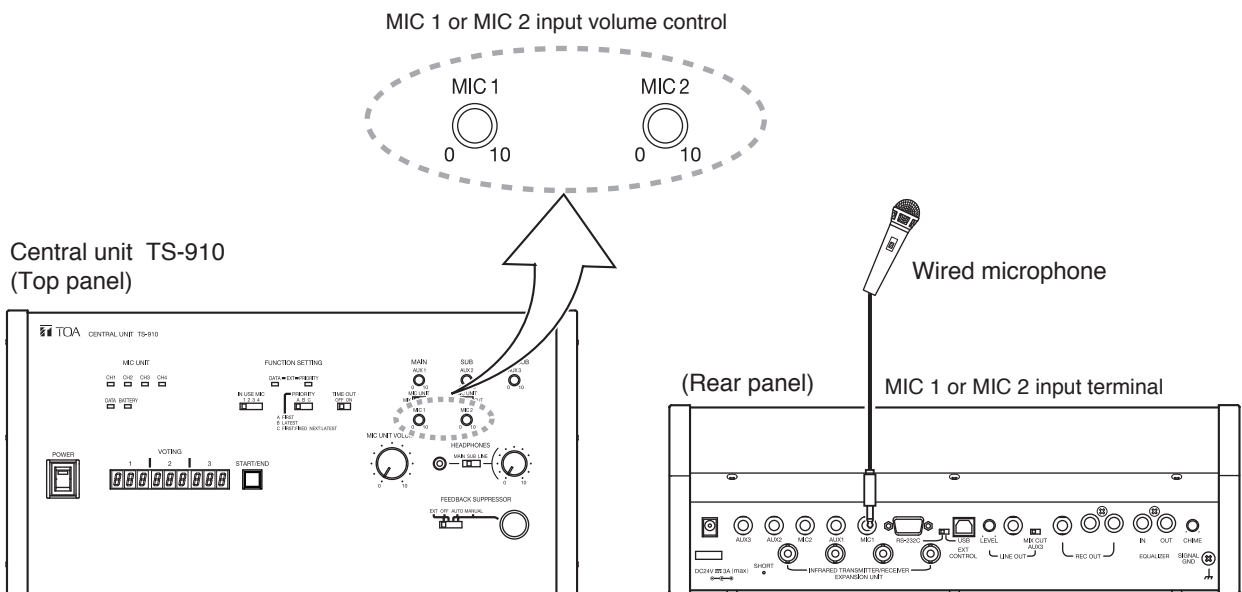

## 8.2. Sound source equipment use

Connect sound source equipment to the Central unit's AUX input and adjust its volume with the corresponding AUX input volume control.

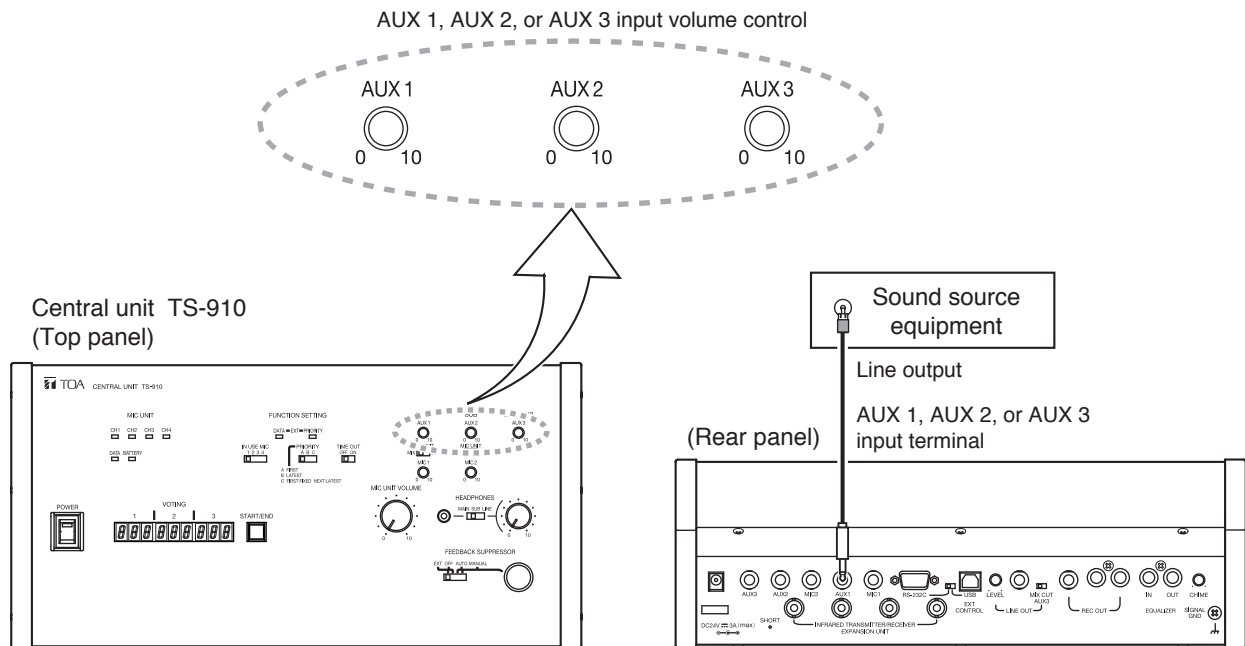

## 9. RECORDING EQUIPMENT CONNECTION

Connect the recorder's recording input terminal to the Central unit's recording output terminal. If the recorder has its recording level control, adjust it to an appropriate recording level.

**Tip:** For operation of the recorder, refer to the instruction manual included with the recorder.

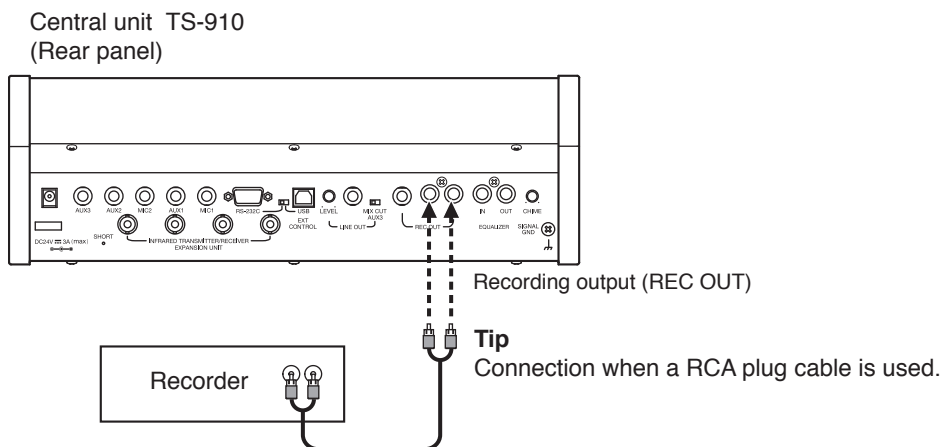

# 10. CONFERENCE UNIT INSTALLATION AND SETTINGS

**Step 1.** Use a screwdriver to set the Unit address number setting switch located on the unit's bottom side. Set a numeral for the one's place and ten's place. As for the hundred's place, shift this switch to OFF for a numeral "0" and to ON for "1." Set the unit address number (001 – 192), taking care to ensure that the same number is not duplicated in the system.

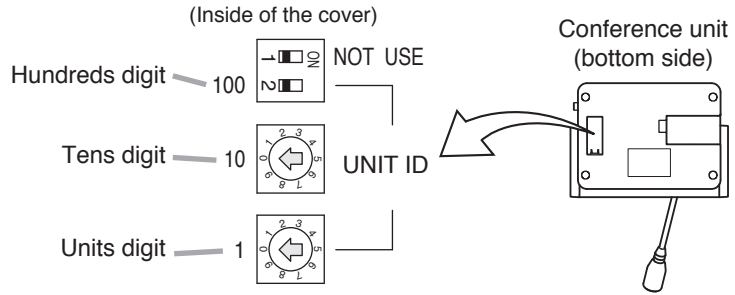

If the number [000] is assigned to a unit, the user of that unit cannot speak. However, the unit can be used for monitoring.

**Note**

This number is factory-preset to [000].

**Step 2.** Mount the microphone to the Conference unit.

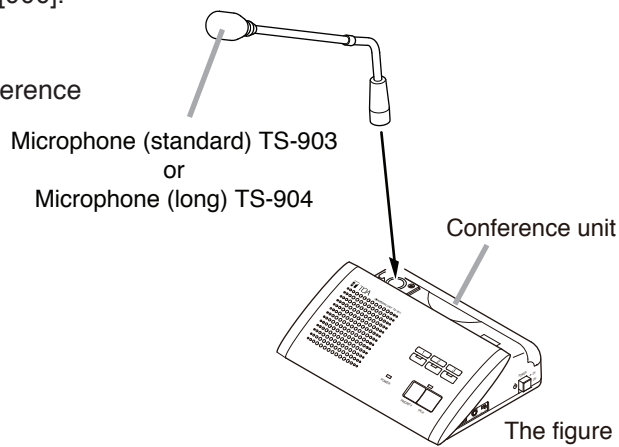

**Step 3.** Set the Priority operation, Priority chime mute, Voting activation, and Priority speech key operation functions using the DIP switch located on the Chairman unit's bottom side.

Setting switch	Factory-preset position
Priority operation setting switch	RESET
Priority chime mute setting switch	OFF
Voting activation setting switch	OFF
Priority speech key operation setting switch	PTT

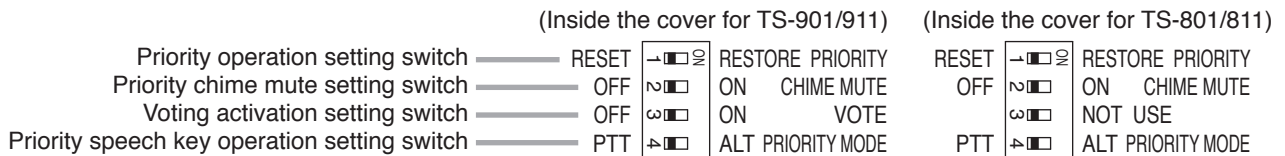
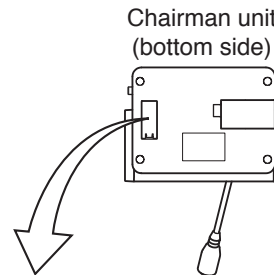

**Step 4.** Turn on the same number of microphones on the Conference units as the maximum number of simultaneous speakers set at the Central unit. Speaking into the microphone, adjust the Central unit's Speech volume control to an appropriate level.

**Step 5.** Initiate speech from the microphones of all Conference units, and confirm that acoustic feedback is not produced. If feedback occurs, widen the distance between the Chairman unit and the Delegate unit or reduce the output volume to prevent feedback. When feedback still remains, use the FBS function built in the Central unit, or an external graphic equalizer to suppress it. (Refer to the separate Operating instructions.)

## 11. INFRARED CONFERENCE UNIT POWER SUPPLY

Use either the optional BP-900 Lithium-Ion Battery or the AD-0910 AC Adapter for the power supply of the Infrared Conference units.

### 11.1. BP-900 Lithium-Ion Battery

#### Note

Before using the BP-900 battery, be sure to carefully read the instructions on its use described in the manual enclosed with the BP-900.

#### 11.1.1. Inserting the lithium-ion battery

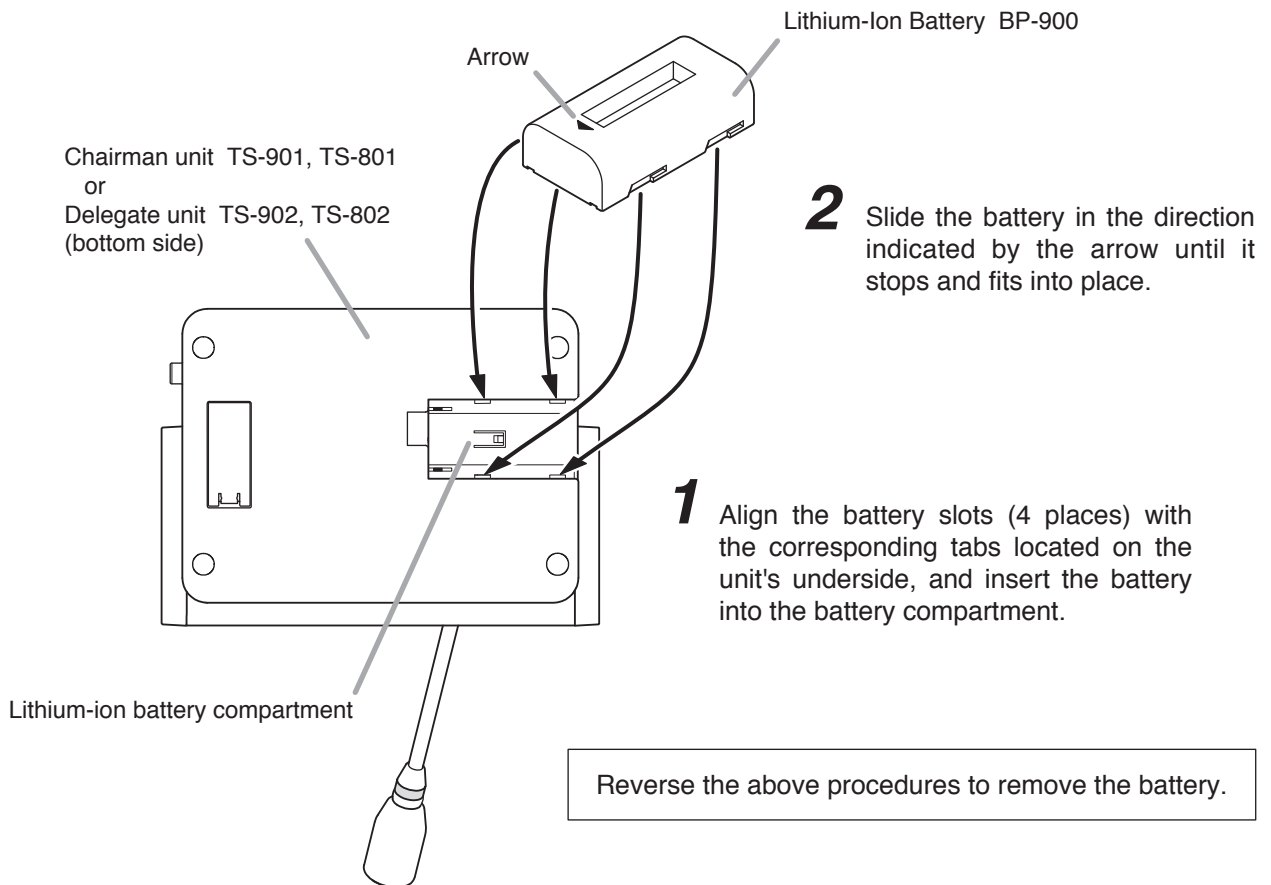

**Note:** A fully charged battery can be continuously used for about 10 hours.

### 11.1.2. Recharging

Use the BC-900 Battery Charger to recharge the BP-900 Lithium-Ion Battery.

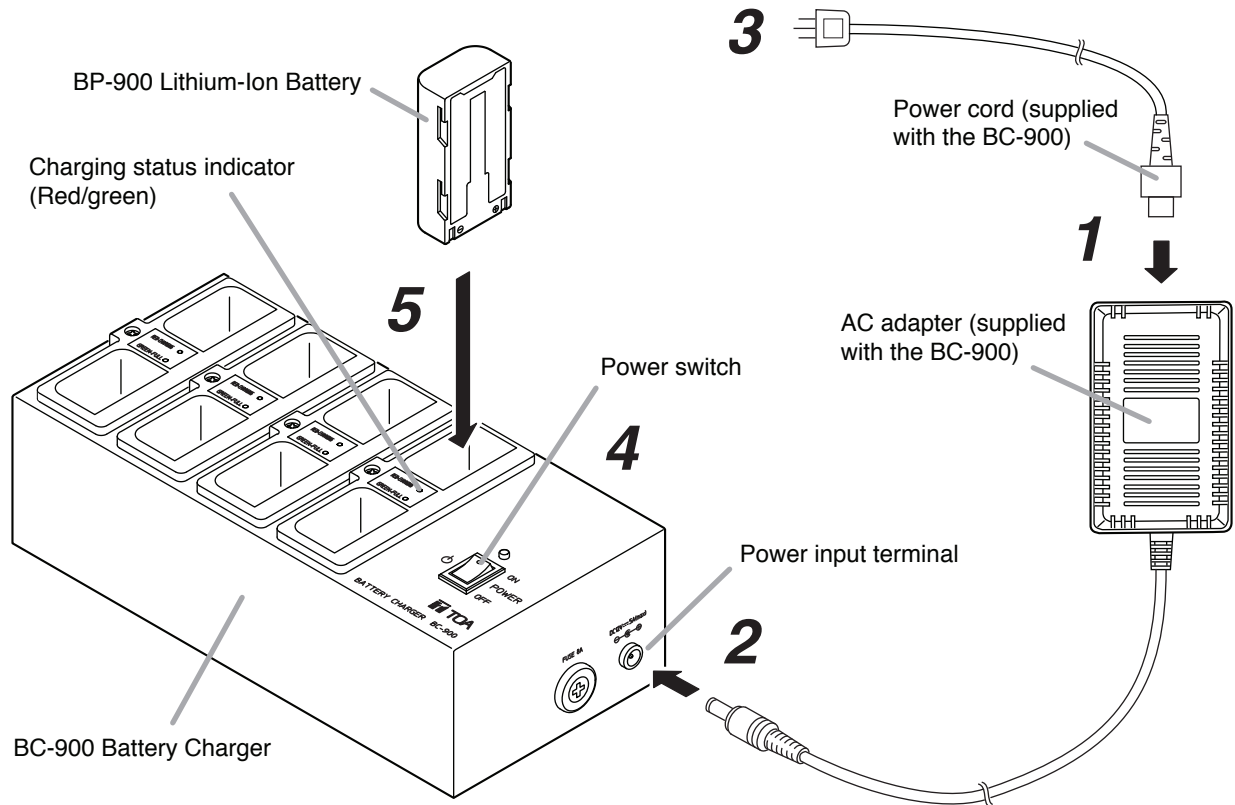

**Step 1.** Connect the power cord to the supplied AC adapter.

**Step 2.** Connect the AC adapter to the Charger's power input terminal.

**Step 3.** Insert the AC plug into the AC wall outlet.

**Step 4.** Turn on the power switch.  
The Power indicator lights green.

**Step 5.** Insert the battery fully into one of the Charger's battery receptacles with the battery oriented to the proper direction.  
Ensure that the charging status indicator lights red. If it does not light, check to see if the battery is correctly inserted.

Charging is completed within 5 hours and the charging status indicator lights green.



## WARNING

Stop charging if batteries are not fully charged within 5 hours. Continuously charging over 5 hours may cause batteries to fire, explode, leak, or heat.



## CAUTION

Remove the power supply plug of charger from the AC outlet after charging completion, as doing otherwise may cause a fire.

### Note

Switching the Charger's power OFF and back ON again with fully-charged (charging completed) batteries inserted will result in repeated recharge of the batteries. Battery life could deteriorate from this repetitive charging.

## 11.2. AD-0910 AC Adapter

Connect the AD-0910 AC Adapter to the DC Inlet located on the left side panel of the Infrared Conference units.

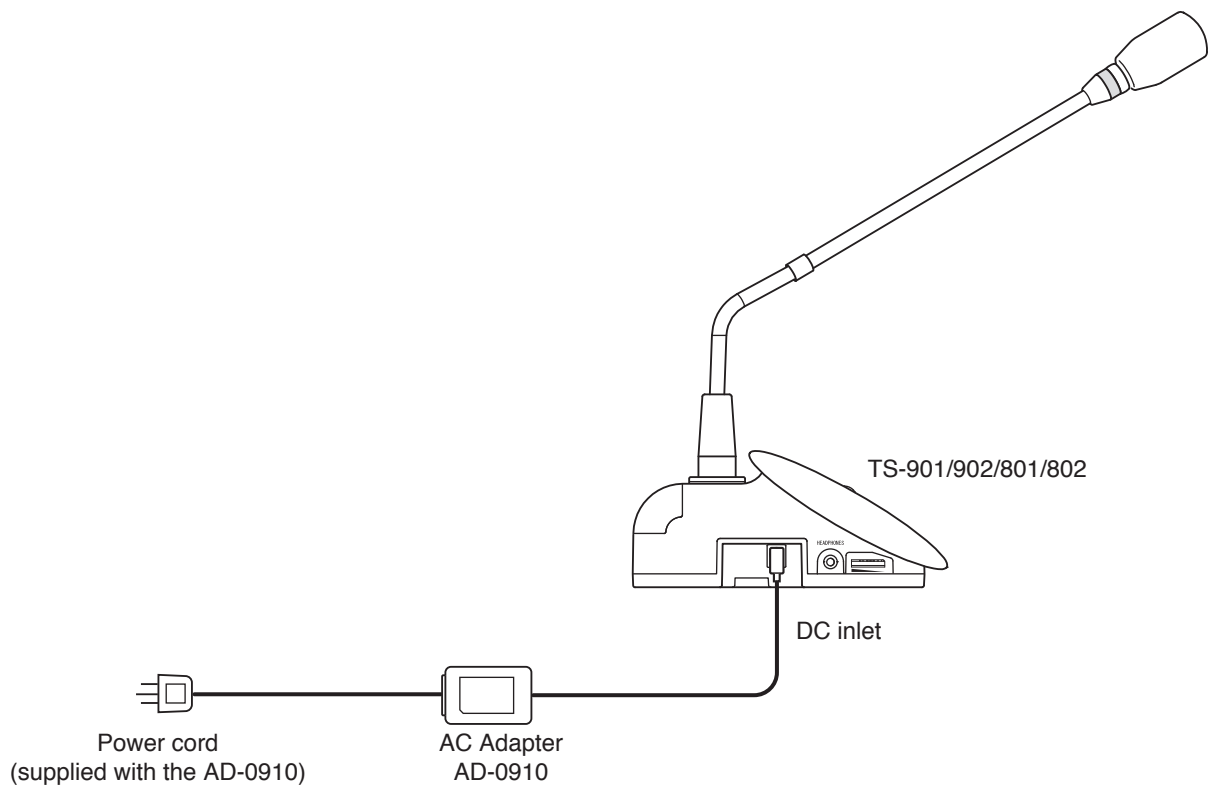

## 12. RACK MOUNTING

### 12.1. Mounting the Central Unit on a Rack

**Step 1.** Detach both side panels of the TS-910 Central Unit.  
Removed screws are used in Step 2.

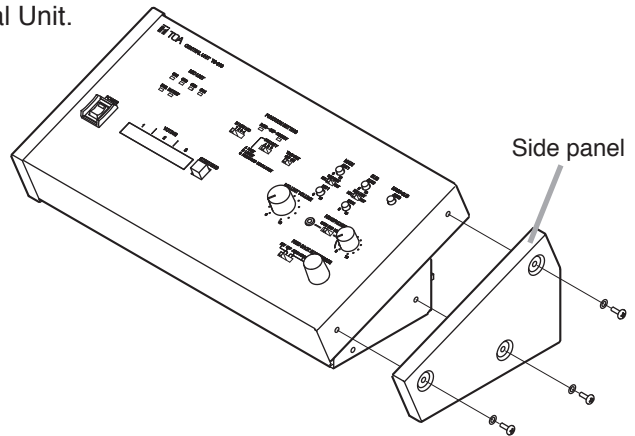

**Step 2.** Attach the MB-TS900 Rack Mounting Bracket to both sides of the Central Unit.  
Use the screws removed in Step 1.

**Step 3.** Mount the Central unit equipped with the mounting brackets in the rack.  
Use the rack mounting screws and fiber washers supplied with the rack mounting bracket.

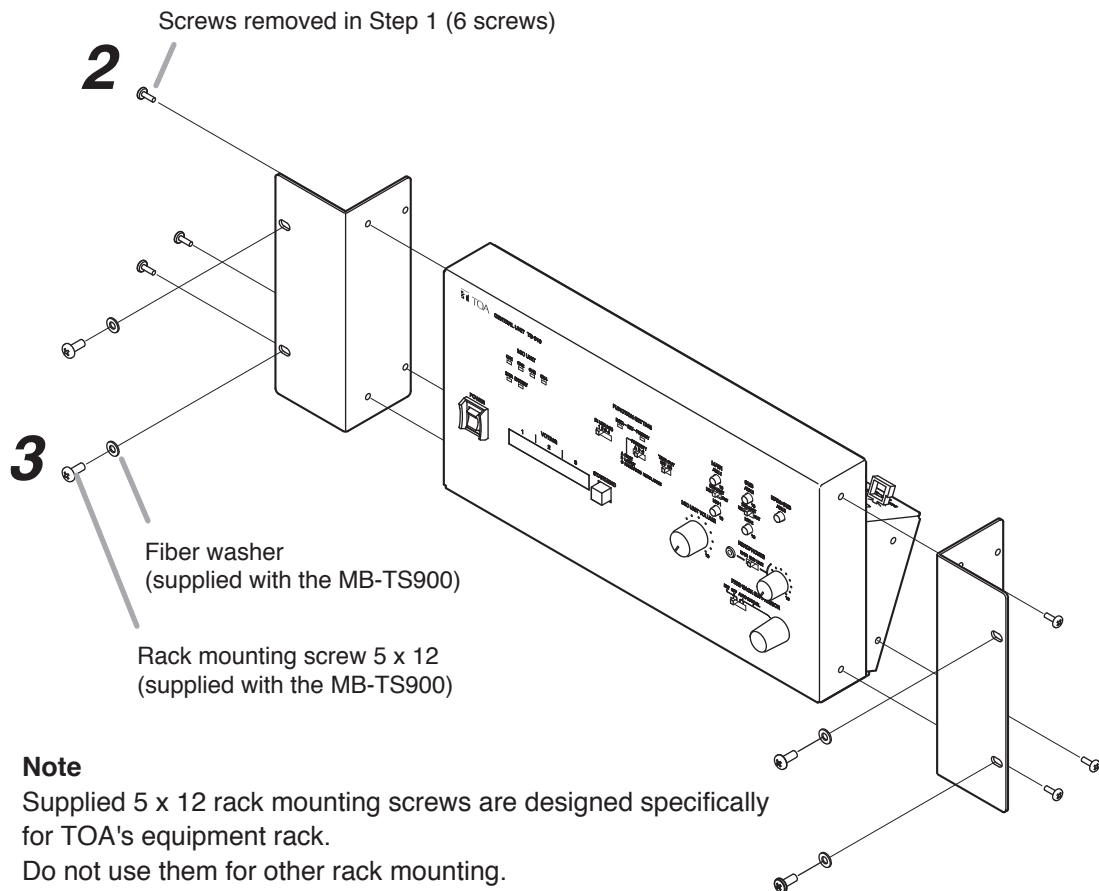

## 12.2. Mounting the Expansion Unit on a Rack

- Use the optional MB-15B-BK hardware set when mounting a single unit.

Remove 8 screws located on both sides of the unit, then attach the optional hardware as shown below.

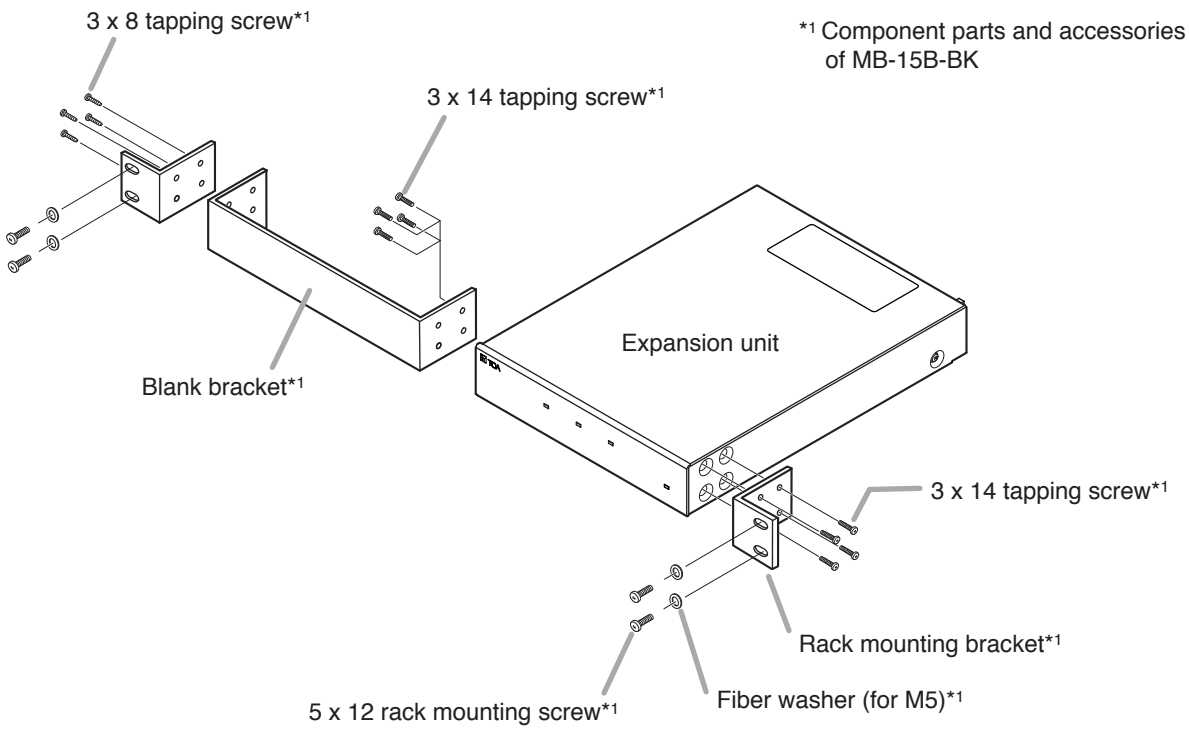

- Use the optional MB-15B-J hardware set when mounting 2 units.

Remove 4 screws each located on left or right side of the unit, then attach the optional hardware as shown below.

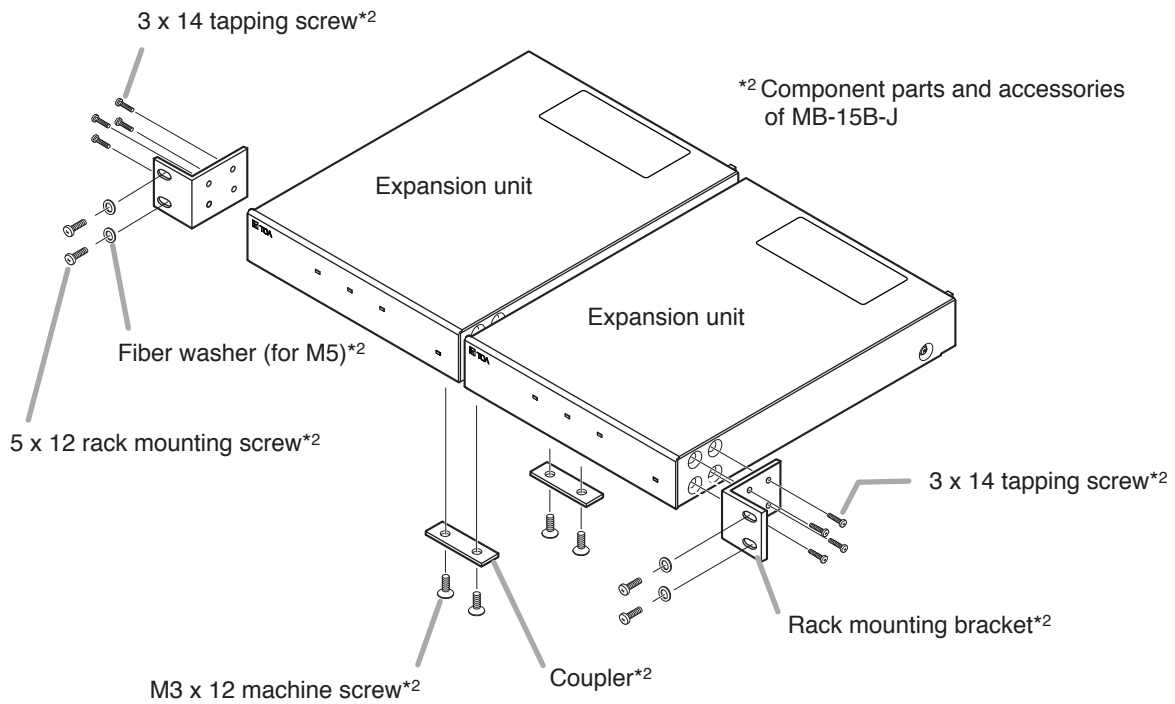



# 13. INSTALLATION STATUS CONFIRMATION

Installation status for the Expansion unit, Bridge unit, Infrared Transmitter/Receiver unit, and Conference units can be checked from the Central unit. Switch on the power to the Conference units to confirm their installation status after completing installation and connection.

**Note**

None of the unit's functions can be used while in installation status confirmation mode, except Priority Speech initiated from the Chairman unit.

**Step 1.** Switch on the power to the Central unit while holding down its Voting Start/End button.

The Central unit's Battery indicator lights, placing the unit in installation confirmation mode.

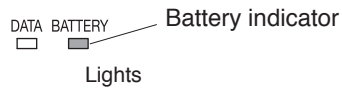

**1-1.** Each segment (1 – 3) of The Central unit's Voting Result display shows [0] and flashes.

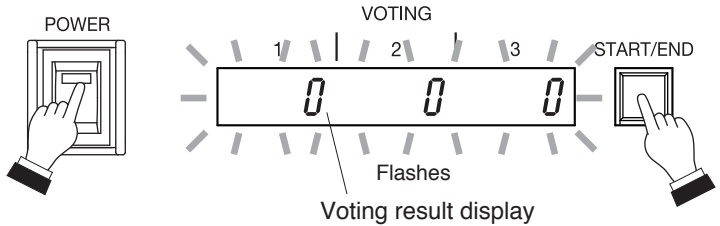

**1-2.** When a connection check signal is output from the Central unit, the microphone in-use indicator on the Conference unit that has received the signal flashes.

**1-3.** An acknowledgement signal is transmitted from each Conference unit.

**1-4.** A response confirmation signal is output from the Central unit that has received the acknowledgement signal, and the microphone in-use indicator on the Conference unit that has received the signal changes from flashing to steady ON.

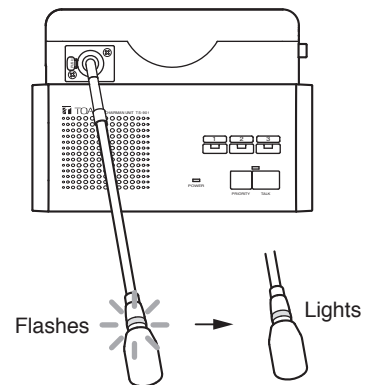

**1-5.** Each segment (1 – 3) of the Voting Result display provides a flashing indication of [the number of installed Chairman units], [the number of installed Delegate units], and [the total number of installed Chairman and Delegate units], respectively.

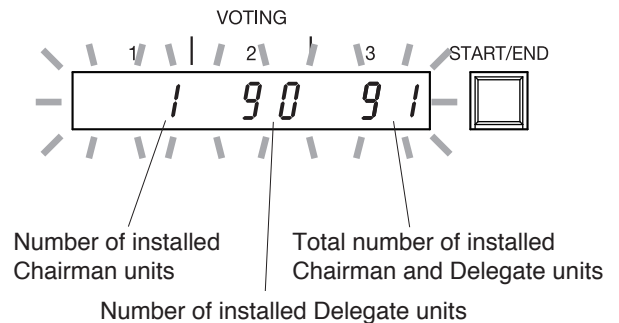

**Step 2.** Press the Voting Start/End button for 1 second or more after confirming the indication.

The Central unit's Battery indicator and Voting Result display (1 – 3) turn off. The microphone in-use indicators on the Conference units also go out, and the installation status confirmation mode is terminated, returning the system to normal operation mode.

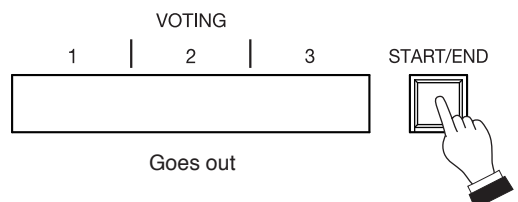

## 14. APPENDIX (INFRARED TRANSMITTER/RECEIVER CONNECTION)

This chapter describes how to find the maximum cable length between the Central unit and the Infrared Transmitter/Receiver unit.

Values calculated here are given only as guidelines, since they can vary depending on ambient building conditions and the Infrared Transmitter/Receiver unit.

### 14.1. Wiring Design

#### 14.1.1. Confirming the wiring design

To obtain the maximum cable length between the Infrared Transmitter/Receiver unit and the Central unit, calculate the cable length on the following each condition. The shorter length of the two results is the required extendable length.

- (1) Maximum allowable wiring loss: 20 dB (Total cable and distributor loss)
- (2) Maximum allowable DC voltage drop: 5 V

Values necessary for each calculation are as follows.

- Values necessary for calculating the loss

- (1) 2-branch distributor (YW-1022) loss: 4.5 dB
- (2) 4-branch distributor (YW-1024) loss: 8.5 dB
- (3) Coaxial cable loss per 100 m (table shown below)

RG-59/U	3.3 dB
RG-6/U	2.7 dB
RG-11/U	2.0 dB

**Note:** The values in the table above are losses at 10 MHz.

- Values necessary for calculating the voltage drop

- (1) Operating current per Infrared Transmitter/Receiver unit: 0.1 A (TS-905), 0.13 A (TS-907)
- (2) Distributor resistance loss: 0  $\Omega$
- (3) Coaxial cable loop resistance per 100 m (table shown below)

RG-59/U	16.82 $\Omega$
RG-6/U	12.82 $\Omega$
RG-11/U	2.4 $\Omega$

**Note:** The values in the table above are losses at 10 MHz.

**Note:** Coaxial cable loss and loop resistance values used here are based on our investigation.

**14.1.2. Computational equation**

- Finding the wiring loss

Requirement: Total loss  $\leq 20$  dB

Cable loss = (Length / 100) x Loss per 100 m

Total loss = Cable 1 loss + Cable 2 loss + Cable 3 loss + Distributor 1 loss + Distributor 2 loss

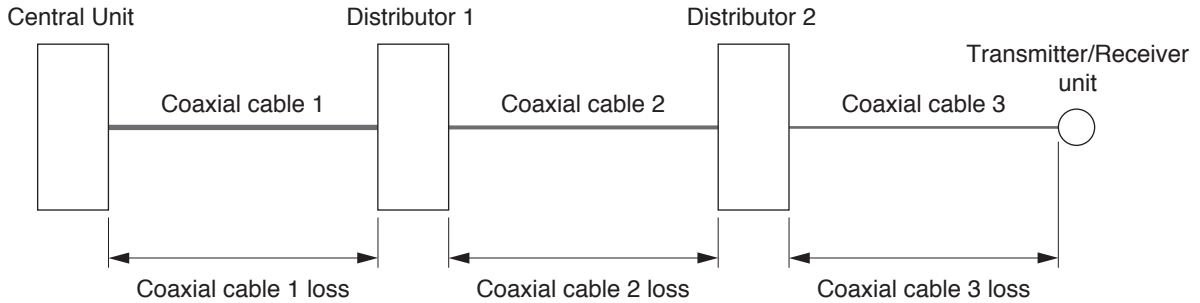

- Finding the wiring voltage drop

Requirement: Total voltage drop  $\leq 5$  V

Cable voltage drop = (Length / 100) x Loop resistance per 100 m x Current

Cable current = Number of the connected Infrared Transmitter/Receiver units x 0.1 (TS-905) or 0.13 (TS-907)

Total voltage drop = Voltage drop 1 + Voltage drop 2 + Voltage drop 3

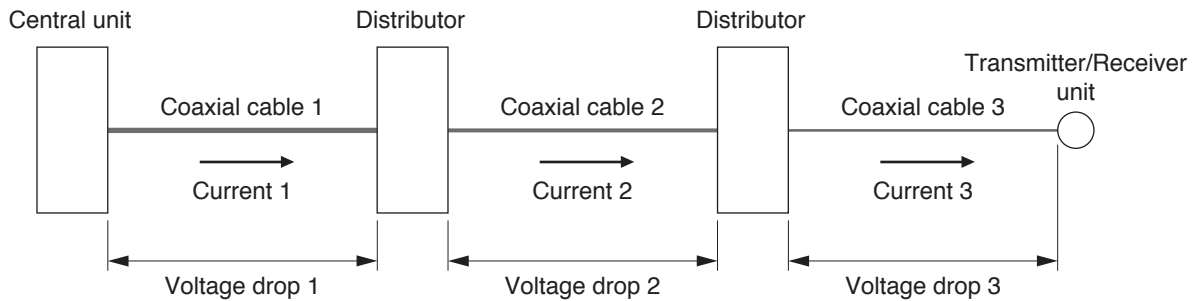

**Note:** For the coaxial cable required to carry a large current, use a cable of low loop resistance type.

**[Finding the cable current]**

Cable current = Number of the connected Infrared Transmitter/Receiver units x 0.1 (TS-905) or 0.13 (TS-907)

The cable current changes when the Distributor is used, as shown below.

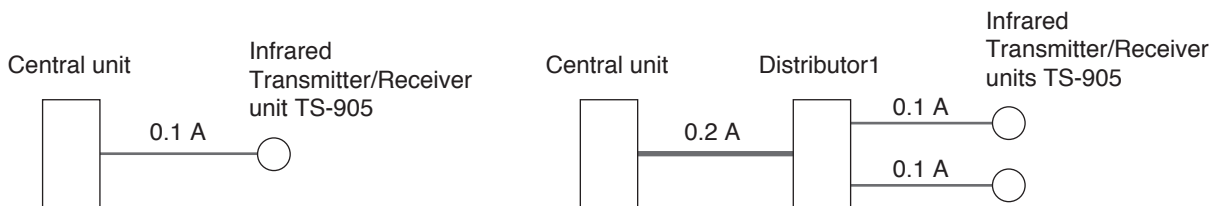

## 14.2. Design Examples

### 14.2.1. Example : When installing 4 TS-905 Infrared Transmitter/Receiver units using 4 coaxial cables reaching from the Central unit:

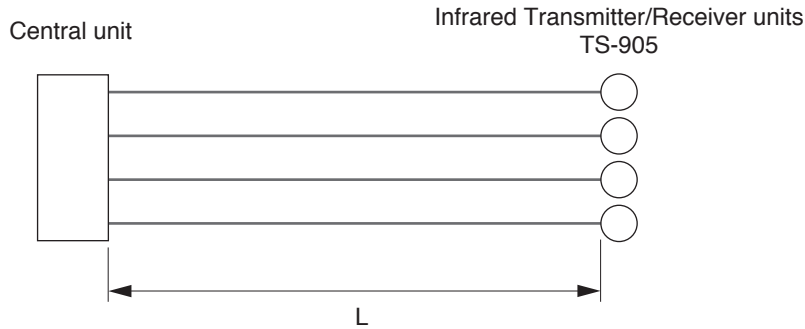

#### 1) Finding the maximum cable length using maximum allowable cable losses

Assuming that the type of coaxial cable used is RG-59/U,

$$\begin{aligned} \text{Maximum cable length } L &= (\text{Coaxial cable loss} / \text{its cable loss per } 100 \text{ m}) \\ &= (20 \text{ dB} / 3.3 \text{ dB}) \times 100 \text{ m} \\ &= 606 \text{ m} \end{aligned}$$

The following table shows the maximum allowable cable length for each type of coaxial cable.

RG-59/U	606 m
RG-6/U	740 m
RG-11/U	1000 m

#### 2) Finding the maximum cable length using voltage drop

Since one TS-905 Infrared Transmitter/Receiver unit is connected per coaxial cable, the current that flows through each coaxial cable is 0.1 A.

Assuming that the type of coaxial cable used is RG-59/U,

$$\begin{aligned} \text{Maximum length } L &= \{ (\text{Voltage drop } 1 / \text{Current } 1) / \text{Coaxial cable loop resistance } 1 \text{ for } 100 \text{ m} \} \\ &= \{ (5 \text{ V} / 0.1 \text{ A}) / 16.82 \Omega \} \times 100 \text{ m} \\ &= 297 \text{ m} \end{aligned}$$

The following table shows the maximum allowable cable length for each type of coaxial cable.

RG-59/U	297 m
RG-6/U	390 m
RG-11/U	2083 m

The table below shows the required maximum cable length for the example 1, the shorter length of the calculation results (1) and (2) above.

RG-59/U	297 m
RG-6/U	390 m
RG-11/U	1000 m

**14.2.2. Example 2: When installing 4 TS-905 Infrared Transmitter/Receiver units using 1 coaxial cable reaching from the Central unit (one 4-branch distributor connected):**

Condition: Cable length between the Distributor and the TS-905 Infrared Transmitter/Receiver unit is assumed to be 50 meters.

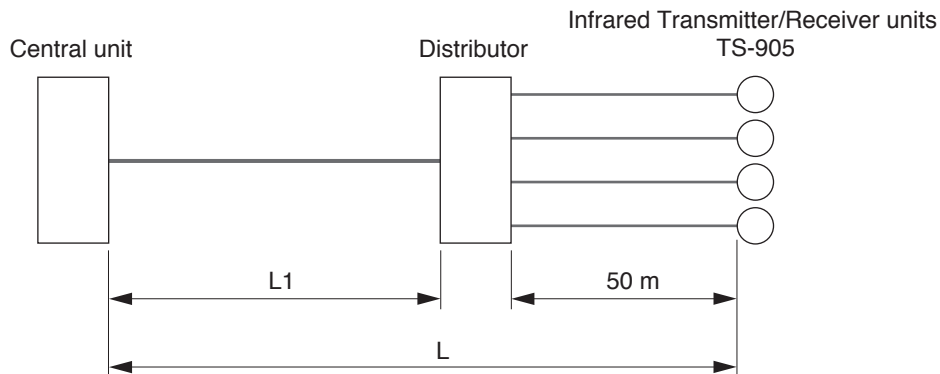

**1) Finding the maximum cable length using maximum allowable cable losses**

Assuming that RG-59/U coaxial cable is used between the Distributor and the Infrared Transmitter/Receiver unit, the cable loss between the two is calculated by the following equation:

$$\text{Cable loss} = 3.3 \text{ dB} \times (50 \text{ m} / 100 \text{ m}) = 1.65 \text{ dB}$$

Since the Distributor's internal loss is 8.5 dB, the maximum allowable loss between the Central unit and the Distributor becomes 9.85 dB (20 dB – 1.65 dB – 8.5 dB).

When RG-6/U coaxial cable is used between the Central unit and the Distributor, the length L1 between the two is,

$$\begin{aligned} L1 &= (\text{Coaxial cable loss} / \text{its cable loss per } 100 \text{ m}) \\ &= (9.85 \text{ dB} / 2.7 \text{ dB}) \times 100 \text{ m} \\ &= 364 \text{ m} \end{aligned}$$

Maximum cable length L between the Central unit and the Infrared Transmitter/Receiver unit is calculated by the following equation:

$$\begin{aligned} L &= L1 + 50 \text{ m} \\ &= 364 \text{ m} + 50 \text{ m} \\ &= 414 \text{ m} \end{aligned}$$

Similarly calculated for other types of coaxial cables, the maximum cable length between the Central unit and the Infrared Transmitter/Receiver unit is found in the following table.

RG-59/U	348 m
RG-6/U	414 m
RG-11/U	542 m

## 2) Finding the maximum cable length using voltage drop

The current flowing from the Distributor into each coaxial cable connected to the TS-905 Infrared Transmitter/Receiver unit is 0.1 A, since the number of Infrared Transmitter/Receiver units connected to each coaxial cable is 1.

Assuming that RG-59/U coaxial cable is used, the voltage drop between the Distributor and the Infrared Transmitter/Receiver unit is calculated by the following equation:

$$\begin{aligned} \text{Voltage drop} &= 16.82 \, \Omega \times (50 \, \text{m} / 100 \, \text{m}) \times 0.1 \, \text{A} \\ &= 0.841 \, \text{V} \end{aligned}$$

A remaining voltage of 4.159 V (5 V – 0.841 V) is the maximum allowable voltage drop between the Central unit and the Distributor. The current that flows between the two is 0.4 A.

When RG-6/U coaxial cable is used between the Central unit and the Distributor, the cable length L1 between the two is,

$$\begin{aligned} L1 &= \{ (\text{Voltage drop } 1 / \text{Current } 1) / \text{Coaxial cable loop resistance } 1 \text{ per } 100 \, \text{m} \} \\ &= \{ (4.159 \, \text{V} / 0.4 \, \text{A}) / 12.82 \, \Omega \} \times 100 \, \text{m} \\ &= 81 \, \text{m} \end{aligned}$$

Maximum cable length L between the Central unit and the Infrared Transmitter/Receiver unit is calculated by the following equation:

$$\begin{aligned} L &= L1 + 50 \, \text{m} \\ &= 81 \, \text{m} + 50 \, \text{m} \\ &= 131 \, \text{m} \end{aligned}$$

Similarly calculated for other types of coaxial cables, the maximum cable length between the Central unit and the Infrared Transmitter/Receiver unit is found in the following table.

RG-59/U	111 m
RG-6/U	131 m
RG-11/U	483 m

The table below shows the required maximum cable length for the example 2, the shorter length of the calculation results (1) and (2) above.

RG-59/U	111 m
RG-6/U	131 m
RG-11/U	483 m

**14.2.3. Example 3: When installing each 4 TS-905 Infrared Transmitter/Receiver units using 4 coaxial cables reaching from the Central unit (four 4-branch distributors connected):**

Condition: Cable length between the Distributor and the TS-905 Infrared Transmitter/Receiver unit is assumed to be 50 meters.

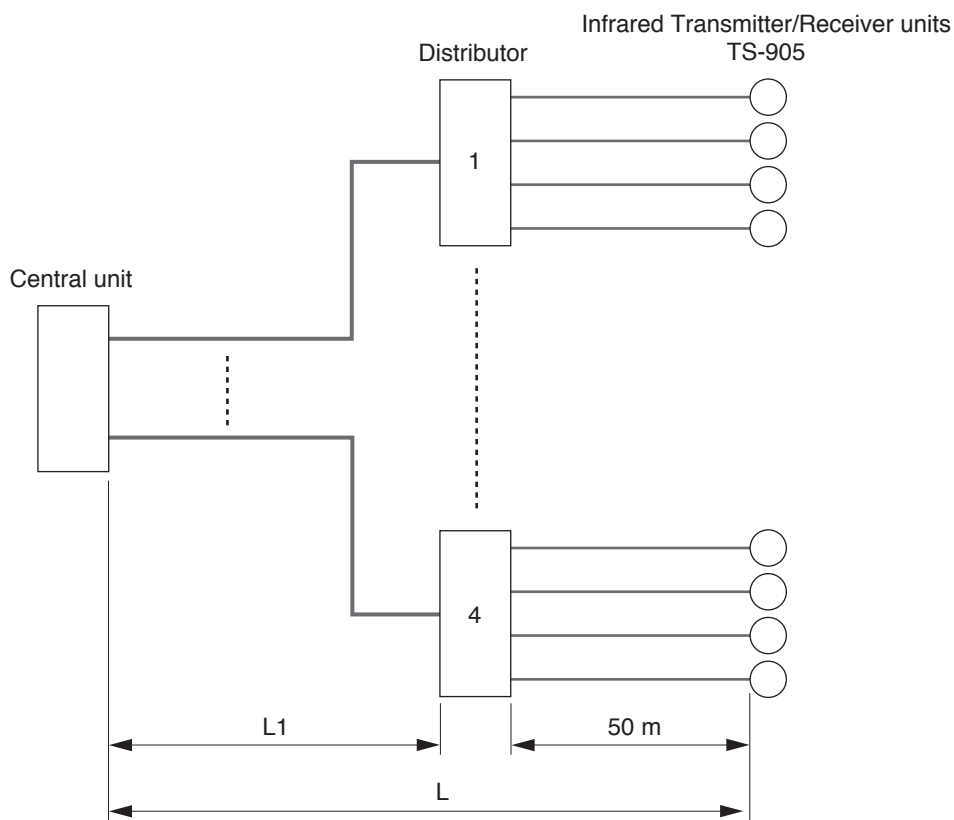

The equation and maximum cable length in this example are the same as those in Example 2 in the previous section on p. 57.

**14.2.4. Example 4: When installing 16 TS-905 Infrared Transmitter/Receiver units using 1 coaxial cable reaching from the Central unit (five 4-branch distributors connected):**

Condition: Length between the Distributor 2 and the TS-905 Infrared Transmitter/Receiver unit is assumed to be 50 meters, and the length between Distributor 1 and Distributor 2 10 meters.

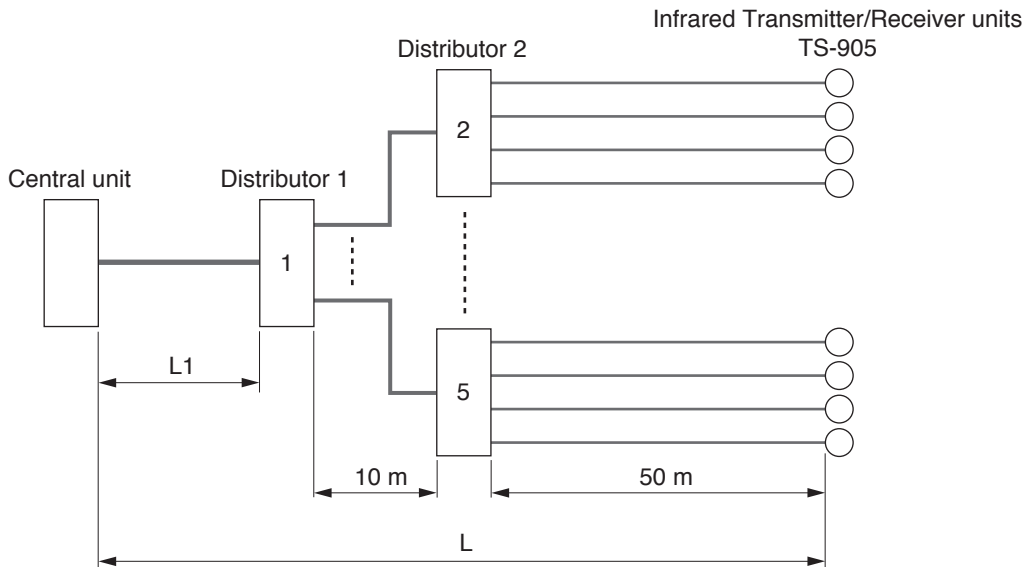

**1) Finding the maximum length using maximum allowable cable losses**

Assuming that RG-59/U coaxial cable is used, the cable loss between the Distributor 2 and the Infrared Transmitter/Receiver unit is calculated by the following equation:

$$\text{Cable loss} = 3.3 \text{ dB} \times (50 \text{ m} / 100 \text{ m}) = 1.65 \text{ dB}$$

Assuming that RG-6/U coaxial cable is used, the cable loss between the Distributor 1 and Distributor 2 is calculated by the following equation:

$$\text{Cable loss} = 2.7 \text{ dB} \times (10 \text{ m} / 100 \text{ m}) = 0.27 \text{ dB}$$

Because of the 2 serially-connected 4-branch distributors, their loss is 17 dB (8.5 dB + 8.5 dB), which is added to the above cable loss, causing a total loss of 18.92 dB (1.65 dB + 0.27 dB + 17 dB). Therefore, the maximum allowable cable loss between the Central unit and the Distributor 1 is calculated to be 1.08 dB (20 dB – 18.92 dB).

- Assuming that RG-11/U coaxial cable is used,  $L_1$  between the Central unit and the Distributor 1 is calculated by the following equation:

$$\begin{aligned} L_1 &= (\text{Coaxial cable loss} / \text{its cable loss per } 100 \text{ m}) \\ &= (1.08 \text{ dB} / 2 \text{ dB}) \times 100 \text{ m} \\ &= 54 \text{ m} \end{aligned}$$

$$\begin{aligned} \text{Maximum cable length } L \text{ (Length between the Central unit and the Infrared Transmitter/Receiver unit)} \\ &= 54 \text{ m} + 10 \text{ m} + 50 \text{ m} = 114 \text{ m} \end{aligned}$$

- Assuming that RG-6/U coaxial cable is used,  $L_1$  between the Central unit and the Distributor 1 is calculated by the following equation:

$$\begin{aligned} L_1 &= (\text{Coaxial cable loss} / \text{its cable loss per } 100 \text{ m}) \\ &= (1.08 \text{ dB} / 2.7 \text{ dB}) \times 100 \text{ m} \\ &= 40 \text{ m} \end{aligned}$$

$$\begin{aligned} \text{Maximum cable length } L \text{ (Length between the Central unit and the Infrared Transmitter/Receiver unit)} \\ &= 40 \text{ m} + 10 \text{ m} + 50 \text{ m} = 100 \text{ m} \end{aligned}$$

Similarly calculated for other types of coaxial cables, the maximum cable length between the Central unit and the Infrared Transmitter/Receiver unit is found in the table.

RG-59/U	92 m
RG-6/U	100 m
RG-11/U	114 m



## 2) Finding the maximum cable length using voltage drop

The current flowing from the Distributor 2 into each coaxial cable connected to the TS-905 Infrared Transmitter/Receiver unit is 0.1 A, since the number of Infrared Transmitter/Receiver units connected to each coaxial cable is 1.

Assuming that RG-59/U coaxial cable is used, the voltage drop between the Distributor 2 and the Infrared Transmitter/Receiver unit is calculated by the following equation:

$$\begin{aligned} \text{Voltage drop} &= 16.82 \, \Omega \times (50 \, \text{m} / 100 \, \text{m}) \times 0.1 \, \text{A} \\ &= 0.841 \, \text{V} \end{aligned}$$

When RG-6/U type coaxial cable is used, since the current flowing into each coaxial cable between Distributor 1 and Distributor 2 is 0.4 A, the voltage drop between the two is calculated by the following equation:

$$\begin{aligned} \text{Voltage drop 2} &= 12.82 \, \Omega \times (10 \, \text{m} / 100 \, \text{m}) \times 0.4 \, \text{A} \\ &= 0.513 \, \text{V} \end{aligned}$$

$$\text{Voltage drop 1} + \text{Voltage drop 2} = 1.354 \, \text{V}$$

A remaining voltage of 3.646 V (5 V – 1.354 V) is the maximum allowable voltage drop between the Central unit and the Distributor 1. The current that flows between the two is 1.6 A.

- Assuming that RG-11/U coaxial cable is used, L1 between the Central unit and the Distributor 1 is calculated by the following equation:

$$\begin{aligned} L1 &= \{ (\text{Voltage drop 1} / \text{Current 1}) / \text{Coaxial cable loop resistance 1 per 100 m} \} \\ &= \{ (3.646 \, \text{V} / 1.6 \, \text{A}) / 2.4 \, \Omega \} \times 100 \, \text{m} \\ &= 94 \, \text{m} \end{aligned}$$

$$\begin{aligned} \text{Maxim cable length L (Length between the Central unit and the Infrared Transmitter/Receiver unit)} \\ &= 94 \, \text{m} + 10 \, \text{m} + 50 \, \text{m} = 154 \, \text{m} \end{aligned}$$

- Assuming that RG-6/U coaxial cable is used, L1 between the Central unit and the Distributor 1 is calculated by the following equation:

$$\begin{aligned} L1 &= \{ (\text{Voltage drop 1} / \text{Current 1}) / \text{Coaxial cable loop resistance 1 per 100 m} \} \\ &= \{ (3.646 \, \text{V} / 1.6 \, \text{A}) / 12.82 \, \Omega \} \times 100 \, \text{m} \\ &= 17 \, \text{m} \end{aligned}$$

$$\begin{aligned} \text{Maxim cable length L (Length between the Central unit and the Infrared Transmitter/Receiver unit)} \\ &= 17 \, \text{m} + 10 \, \text{m} + 50 \, \text{m} = 77 \, \text{m} \end{aligned}$$

Similarly calculated for other types of coaxial cables, the maximum cable length between the Central unit and the Infrared Transmitter/Receiver unit is found in the following table.

RG-59/U	73 m
RG-6/U	77 m
RG-11/U	154 m

The table below shows the required maximum cable length for the example 4, the shorter length of the calculation results (1) and (2) above.

RG-59/U	73 m
RG-6/U	77 m
RG-11/U	114 m

# 15. SIGNAL FLOW DIAGRAM INSIDE THE CENTRAL UNIT

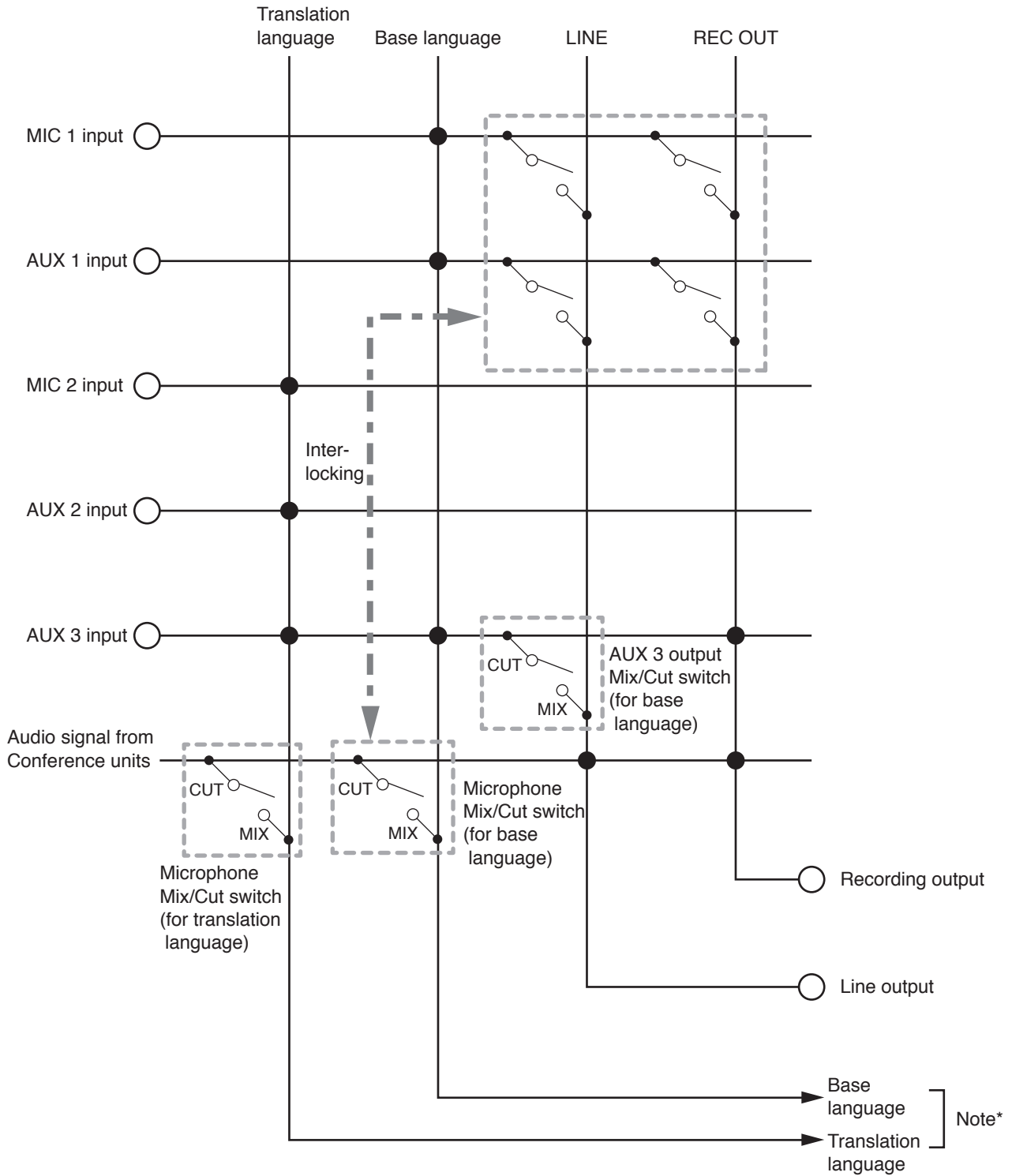

\* Sent to each Conference unit via Infrared Transmitter/Receiver or Expansion unit.



**Traceability Information for Europe**

Manufacturer:  
TOA Corporation  
7-2-1, Minatojima-Nakamachi, Chuo-ku, Kobe, Hyogo,  
Japan

Authorized representative:  
TOA Electronics Europe GmbH  
Suederstrasse 282, 20537 Hamburg,  
Germany