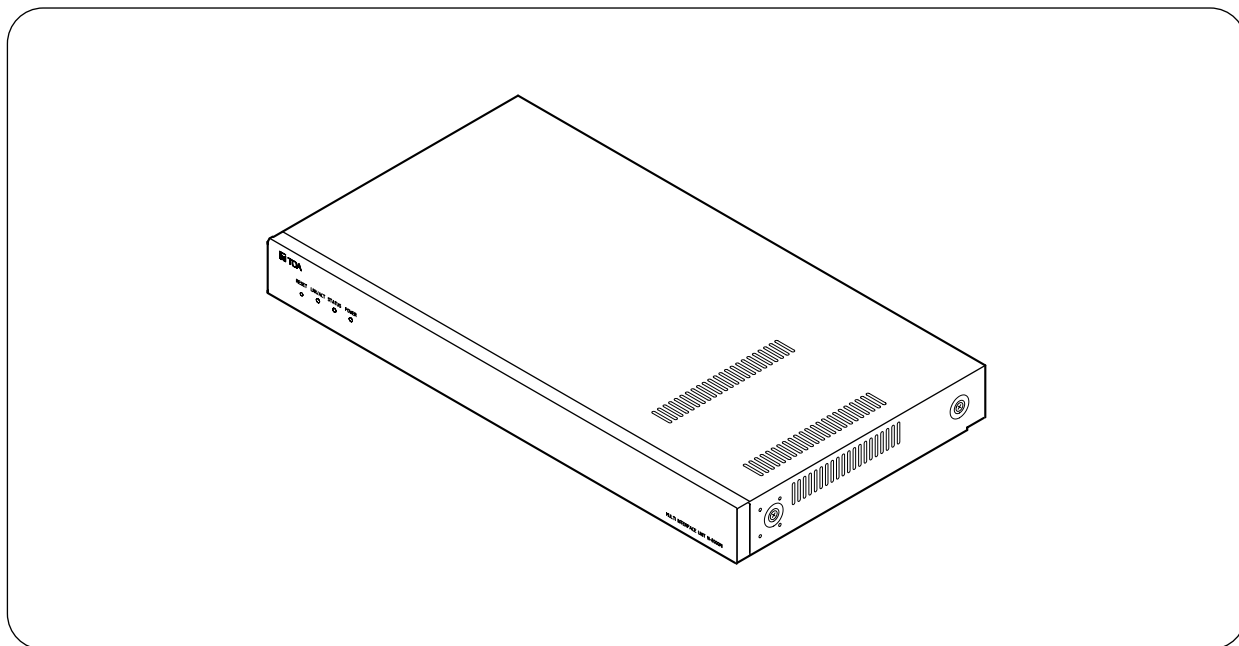

**MULTI INTERFACE UNIT**
**N-8000MI**

**TABLE OF CONTENTS**

<b>1. SAFETY PRECAUTIONS</b> .....	2	<b>7. INSTALLATION</b>	
<b>2. GENERAL DESCRIPTION</b> .....	3	7.1. Equipment Rack Mounting .....	6
<b>3. FEATURES</b> .....	3	7.2. Desk-Top Installation .....	7
<b>4. SPECIFICATIONS</b> .....	3	7.3. Wall Mounting .....	7
<b>5. SYSTEM CONFIGURATION EXAMPLE</b> ....	4	<b>8. Wiring</b>	
<b>6. NOMENCLATURE AND FUNCTIONS</b>		8.1. Connection Diagram .....	8
Front .....	5	8.2. Type of Cable .....	11
Rear .....	5	8.3. Connector Connection .....	11
		<b>9. ACCESSORIES</b> .....	12

Thank you for purchasing TOA's Multi Interface Unit.

Please carefully follow the instructions in this manual to ensure long, trouble-free use of your equipment.

# 1. SAFETY PRECAUTIONS

- Before installation or use, be sure to carefully read all the instructions in this section for correct and safe operation.
- Be sure to follow all the precautionary instructions in this section, which contain important warnings and/or cautions regarding safety.
- After reading, keep this manual handy for future reference.

## Safety Symbol and Message Conventions

Safety symbols and messages described below are used in this manual to prevent bodily injury and property damage which could result from mishandling. Before operating your product, read this manual first and understand the safety symbols and messages so you are thoroughly aware of the potential safety hazards.

### **WARNING**

Indicates a potentially hazardous situation which, if mishandled, could result in death or serious personal injury.

#### When Installing the Unit

- Do not expose the unit to rain or an environment where it may be splashed by water or other liquids, as doing so may result in fire or electric shock.
- Use the unit only with the voltage specified on the unit. Using a voltage higher than that which is specified may result in fire or electric shock.
- Do not cut, kink, otherwise damage nor modify the power supply cord. In addition, avoid using the power cord in close proximity to heaters, and never place heavy objects -- including the unit itself -- on the power cord, as doing so may result in fire or electric shock.
- Avoid installing or mounting the unit in unstable locations, such as on a rickety table or a slanted surface. Doing so may result in the unit falling down and causing personal injury and/or property damage.
- Install the unit only in a location that can structurally support the weight of the unit and the mounting bracket. Doing otherwise may result in the unit falling down and causing personal injury and/or property damage.

#### When the Unit is in Use

- Should the following irregularity be found during use, immediately switch off the power, disconnect the power supply plug from the AC outlet and contact your nearest TOA dealer. Make no further attempt to operate the unit in this condition as this may cause fire or electric shock.
  - If you detect smoke or a strange smell coming from the unit.
  - If water or any metallic object gets into the unit
  - If the power supply cord is damaged (exposure of the core, disconnection, etc.)
  - If it is malfunctioning (no tone sounds.)
- To prevent a fire or electric shock, never open nor remove the unit case as there are high voltage

components inside the unit. Refer all servicing to your nearest TOA dealer.

- Do not touch a plug during thunder and lightning, as this may result in electric shock.

### **CAUTION**

Indicates a potentially hazardous situation which, if mishandled, could result in moderate or minor personal injury, and/or property damage.

#### When Installing the Unit

- Never plug in nor remove the power supply plug with wet hands, as doing so may cause electric shock.
- When unplugging the power supply cord, be sure to grasp the power supply plug; never pull on the cord itself. Operating the unit with a damaged power supply cord may cause a fire or electric shock.
- Do not block the ventilation slots in the unit's cover. Doing so may cause heat to build up inside the unit and result in fire.
- Be sure to follow the instructions below when rack-mounting the unit. Failure to do so may cause a fire or personal injury.
  - Install the equipment rack on a stable, hard floor. Fix it with anchor bolts or take other arrangements to prevent it from falling down.
  - To rack-mount the unit, use the supplied rack mounting hardware.
  - When connecting the unit's power cord to an AC outlet, use the AC outlet with current capacity allowable to the unit.

#### When the Unit is in Use

- Do not place heavy objects on the unit as this may cause it to fall or break which may result in personal injury and/or property damage. In addition, the object itself may fall off and cause injury and/or damage.
- Do not stand or sit on, nor hang down from the unit as this may cause it to fall down or drop, resulting in personal injury and/or property damage.

## 2. GENERAL DESCRIPTION

The N-8000MI is a multi interface unit designed for use with TOA's packet intercom system (IP network-compatible intercom system) that employs the packet audio technology\*. Connecting the multi interface to a local area network permits the ideal system for in-house or wide-area information transmission applications, such as paging, periodical broadcasts, and background music broadcasts, to be built between the multi interface and IP intercom exchange or other multi interface unit. The contact bridge function can be realized through contact input and output control.

\* Technology related to audio transmission over a network.

### Warning

This is a class A product. In a domestic environment this product may cause radio interference in which case the user may be required to take adequate measures.

## 3. FEATURES

- N-8000MI units can be distributed over a data communications network.
- Can be connected to an existing local area network (LAN) or wide-area network (WAN). The unit can also be easily connected to fiber-optic networks without restrictions on operating distance.
- The dedicated software program enables centralized control with a personal computer.
- System maintenance (verifying operation log and Line supervision) can also be performed with a personal computer and Internet browser.
- Can be connected to the Exchange of the EXES-2000 or EXES-6000 Intercom System by a tie-line, or the PBX exchange via the OD (out-band-dialing) trunk.
- The unit can interlock with an electronic lock system or CCTV surveillance system by way of contact input/output control function.

## 4. SPECIFICATIONS

Number of Units	
Connectable to LAN:	Maximum 80 (a total of Exchanges and Multi Interface Units)
Speech Link Capacity	2 links Speech: Maximum 2 links Audio input: Maximum 2 links Audio output: Maximum 2 links
	<b>Note</b> The above links can be simultaneously used. (Refer to the table in the next page.)
	Simultaneous access capacity for paging links Multicast paging: Maximum 2 links Unicast paging: 1 link
Paging Zones:	Maximum 160 (With 80 Multi Interface Units)
Paging Zone Via Network:	Maximum 79 (Multicast paging), Maximum 16 (Unicast paging)
BGM Input:	Maximum 8 channels (Number of inputs per exchange)
PBX Interface:	Maximum 160 (When 80 Multi Interface Units are connected)
Tie-line Interface:	Maximum 160 (When 80 Multi Interface Units are connected)
External Contact Output:	Maximum 160 (When 80 Multi Interface Units are connected)
External Contact Input:	Maximum 160 (When 80 Multi Interface Units are connected)
System Settings:	Personal computer setting using a dedicated software program (over LAN)
(Network Related)	
Voice Delay Time:	80 or 320 ms, selectable
Connection Delay Time:	Maximum 1 second (When multicast paging is made to 79 zones)
Usage Bandwidth:	Maximum 2.08 Mbps (one way)/When 16 Unicast paging are made Maximum 130 kbps (two-way)/one call

## 5. SYSTEM CONFIGURATION EXAMPLE

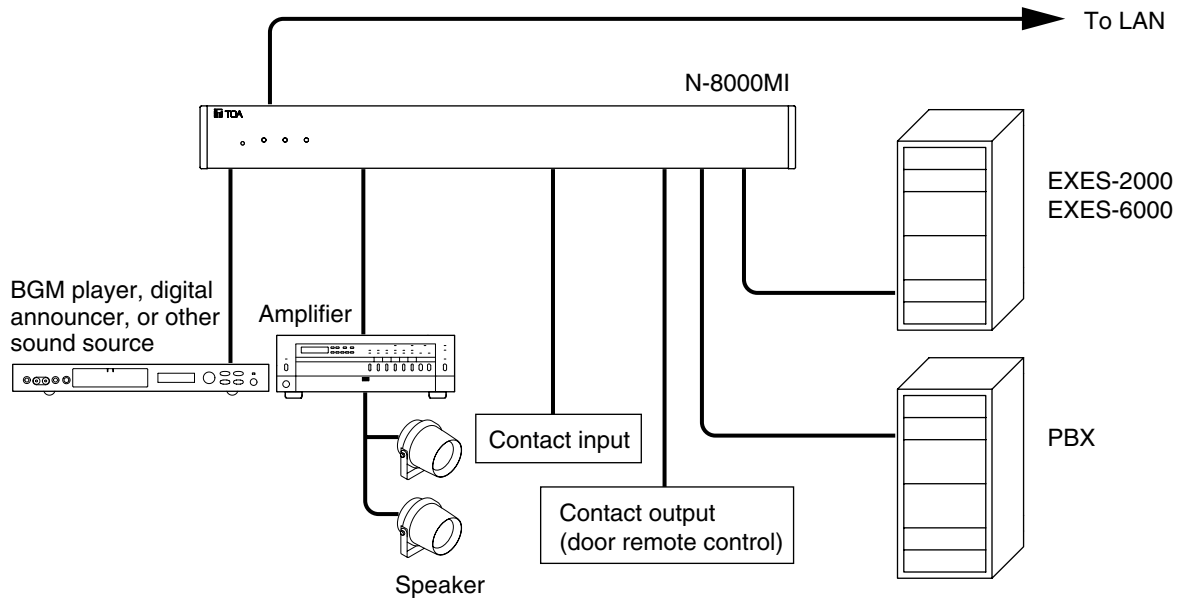

Having 2 channels each for audio input and output, and 16 contacts each for control input and output, the N-8000MI performs the following interface functions\*.

- Tie-line interface for connection with the EXES-2000 and EXES-6000 systems.
- PBX interface for connection with the PBX via the OD trunk.
- PA paging interface for connection with PA equipment
- External input broadcast interface for connection with a music player (chime unit) or paging microphone irrespective of with or without remote control function.
- Interface to control an indicator or external equipment such as a CCTV's switcher using relay contacts.

The N-8000MI also features Network interface for connection with an IP intercom exchange or other multi interface unit.

\* The interface functions can be combined in the following 9 patterns.

Interface function	Combination pattern								
	1	2	3	4	5	6	7	8	9
PBX 1	✓	✓	✓	—	—	—	—	—	—
PBX 2	✓	—	—	✓	✓	—	—	—	—
Tie-line 1	—	—	—	✓	—	✓	✓	—	—
Tie-line 2	—	✓	—	—	—	✓	—	✓	—
Audio output 1	—	—	—	—	✓	—	—	✓	✓
Audio output 2	—	—	✓	—	—	—	✓	—	✓
Audio input 1	—	—	—	—	✓	—	—	✓	✓
Audio input 2	—	—	✓	—	—	—	✓	—	✓
Contact IN/OUT	✓	✓	✓	✓	✓	✓	✓	✓	✓

# 6. NOMENCLATURE AND FUNCTIONS

## [Front]

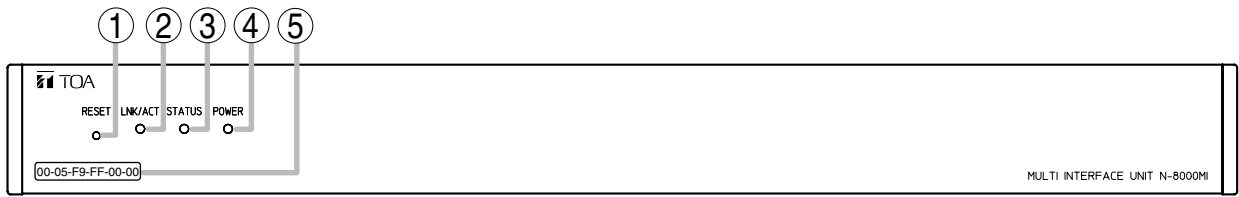

### 1. Reset key [RESET]

Pressing this key reactivates the exchange.

### 2. LNK/ACT indicator [LNK/ACT] (Green)

Lights when connected to a network, and flashes while transmitting or receiving data.

### 3. Status indicator [STATUS] (Red)

Continuously lights while data is written to an internal storage medium (FlashMemory).  
Flashes if there is a failure.

### 4. Power indicator [POWER] (Green)

Lights when power is supplied to the unit.

### 5. MAC address

This is the address\*1 used by the unit. Since the relationship of each exchange location to its MAC address is established when setting the network attributes, keep track of this relationship for later use.

\*1 The inherent address assigned to each network component, expressed in 12-digit hexadecimal notation.

## [Rear]

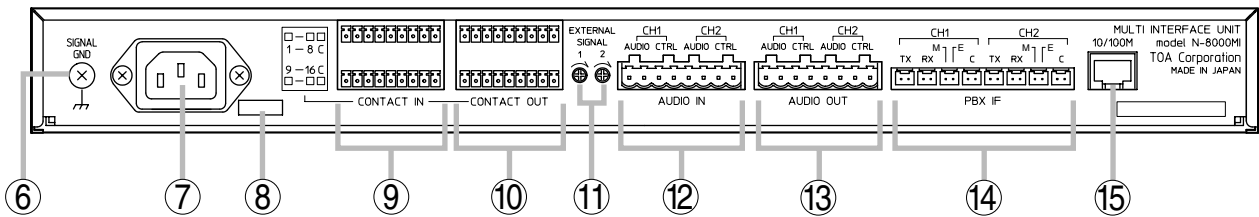

### 6. Functional earth terminal [SIGNAL GND]

Be sure to ground this terminal unless the unit connects to a PBX.

**Note:** This terminal is not for protective earth.

### 7. AC inlet

Connects the supplied power cord.

### 8. Cord clamp

Pass the power cord through this clamp to ensure that the plug does not pull out when the unit is mounted to a wall. (Refer to p. 7.)

### 9. Contact input terminals [CONTACT IN]

No-voltage make contact inputs.

Short-circuit current: 10 mA, Open-circuit voltage: 12 V

### 10. Contact output terminals [CONTACT OUT]

Relay contact outputs.

Withstand voltage: 24 V DC, Control current: Maximum 0.5 A

### 11. Audio input level controls [EXTERNAL SIGNAL 1, 2]

Use these controls to adjust the audio input

levels for channels 1 and 2 according to the input sources.

### 12. Audio input terminal [AUDIO IN]

Includes audio inputs (maximum 0 dB\*2, over 10 kΩ, balanced) and contact inputs (no-voltage make contact, short-circuit current: 10 mA, open-circuit voltage: 12 V).

### 13. Audio output terminal [AUDIO OUT]

Includes audio outputs (maximum 0 dB\*2, under 600 Ω, balanced) and control outputs (relay contact withstand voltage: 24 V DC, control current: maximum 0.5 A).

### 14. PBX interface terminal [PBX IF]

Connects to the Exchange of the EXES-2000 or EXES-6000 system by a tie-line, or the PBX exchange via the OD (out-band-dialing) trunk.

### 15. Network connection terminal [10/100M]

Connects to a 10BASE-T- or 100BASE-TX-compatible network. (Ethernet RJ45 jack)

\*2 0 dB = 1 V

## 7. INSTALLATION

The N-8000MI can be installed in any of three ways: (1) equipment rack mounting, (2) wall mounting, and (3) desk-top installation.

### 7.1. Equipment Rack Mounting

- A) Elevated Operating Ambient - If installed in a closed or multi-unit rack assembly, the operating ambient temperature of the rack environment may be greater than room ambient. Therefore, consideration should be given to installing the equipment in an environment compatible with the maximum ambient temperature (T<sub>ma</sub>) specified by the manufacturer.
- B) Reduced Air Flow - Installation of the equipment in a rack should be such that the amount of air flow required for safe operation of the equipment is not compromised.
- C) Mechanical Loading - Mounting of the equipment in the rack should be such that a hazardous condition is not achieved due to uneven mechanical loading.
- D) Circuit Overloading - Consideration should be given to the connection of the equipment to the supply circuit and the effect that overloading of the circuits might have on overcurrent protection and supply wiring. Appropriate consideration of equipment nameplate ratings should be used when addressing this concern.
- E) Reliable Earthing - Reliable earthing of rack-mounted equipment should be maintained. Particular attention should be given to supply connections other than direct connections to the branch circuit (e.g. use of power strips)."

The N-8000MI can be mounted on the CR-273 or CR-413 or standard EIA 19" Equipment rack. For the CR-273 and CR-413 Equipment rack assembly, read the installation manual supplied with the rack.

#### Note

When installing the N-8000MI, lay the equipment rack down face-up to do installation work safely.

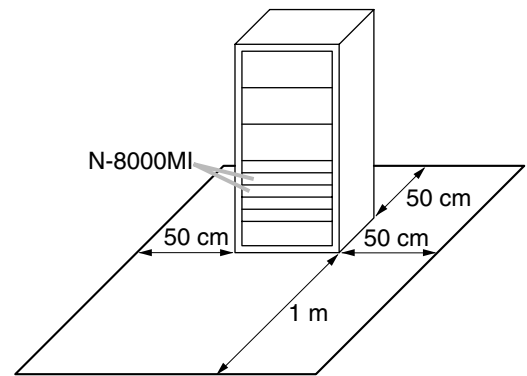

#### 7.1.1. Setting space

For maintenance works, allow much space between the wall and Equipment rack.

#### 7.1.2. Caution when installing the unit

#### **CAUTION**

Do not block the ventilation slots. Doing so may cause heat to build up inside the unit and result in fire.

Do not stack up 3 units or more. If 2 or more units are mounted in the Equipment rack, be sure to mount the perforated panel of 1 U size (PF-013B) or more above and below every 2 units.

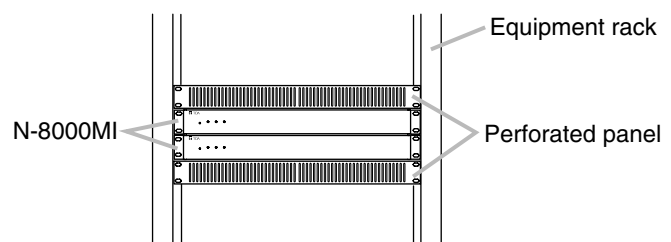

#### 7.1.3. N-8000MI mounting

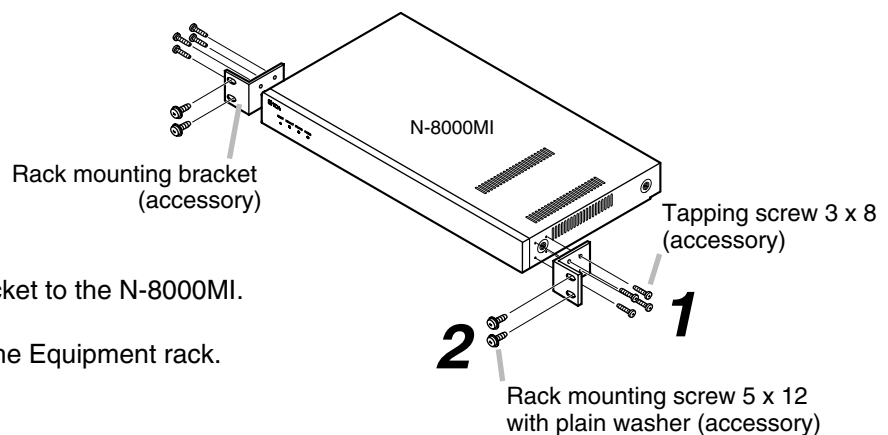

**Step 1.** Install rack-mounting bracket to the N-8000MI.

**Step 2.** Mount the N-8000MI on the Equipment rack.

## 7.2. Desk-Top Installation

When installing the N-8000MI on a desk, secure the supplied plastic feet to the unit's bottom using the supplied tapping screws.

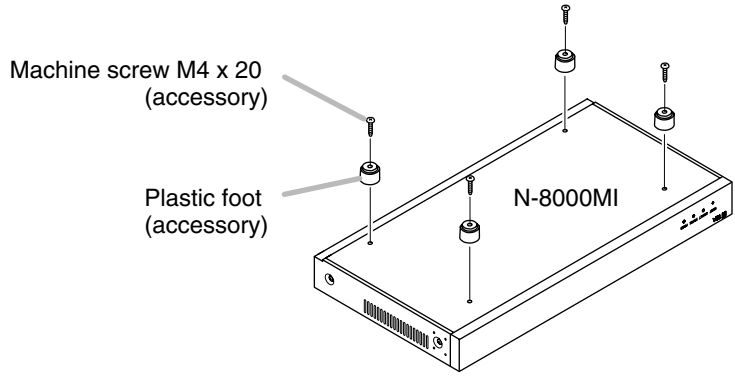

## 7.3. Wall Mounting

**Step 1.** Install the supplied wall-mounting bracket to the N-8000MI using 4 removed screws from the case.

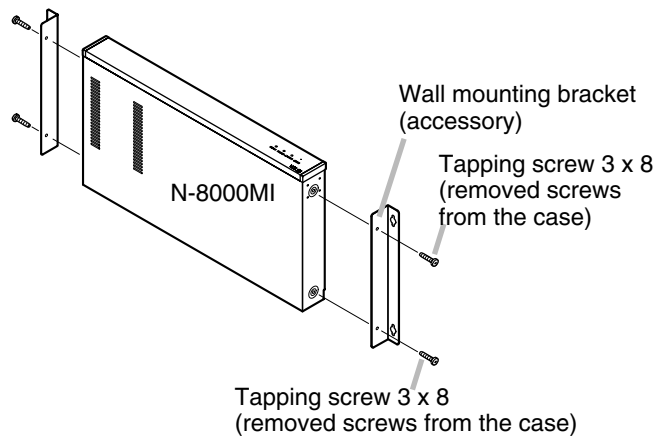

**Step 2.** Mount the N-8000MI on the wall.

### Notes

- Use appropriate screws for the construction of wall.
- Wooden screws 3.5 x 20 are supplied with the N-8000MI.
- The socket-outlet shall be installed near the equipment and shall be easily accessible.

**Protect against disconnection (Power supply plug)**

Unlock cord clamp and run the power supply cord through it.

**Note**  
Keep the cable length between a power supply plug and cord clamp as short as possible.

Power supply cord

Cord clamp

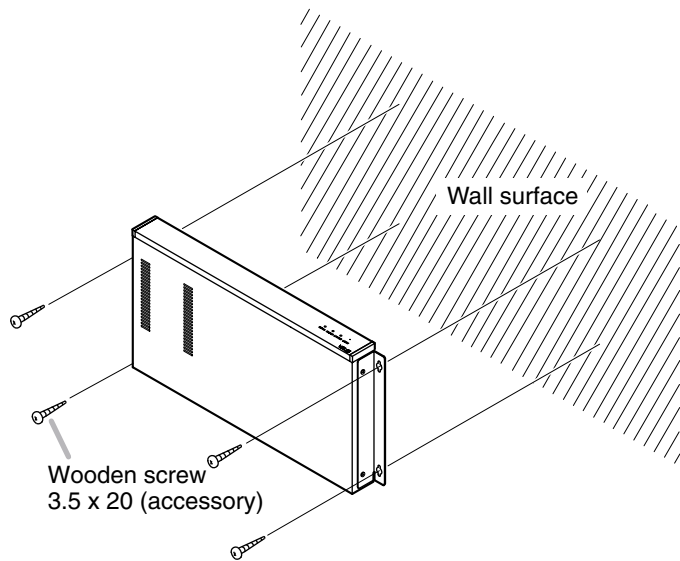

# 8. WIRING

## 8.1. Connection Diagram

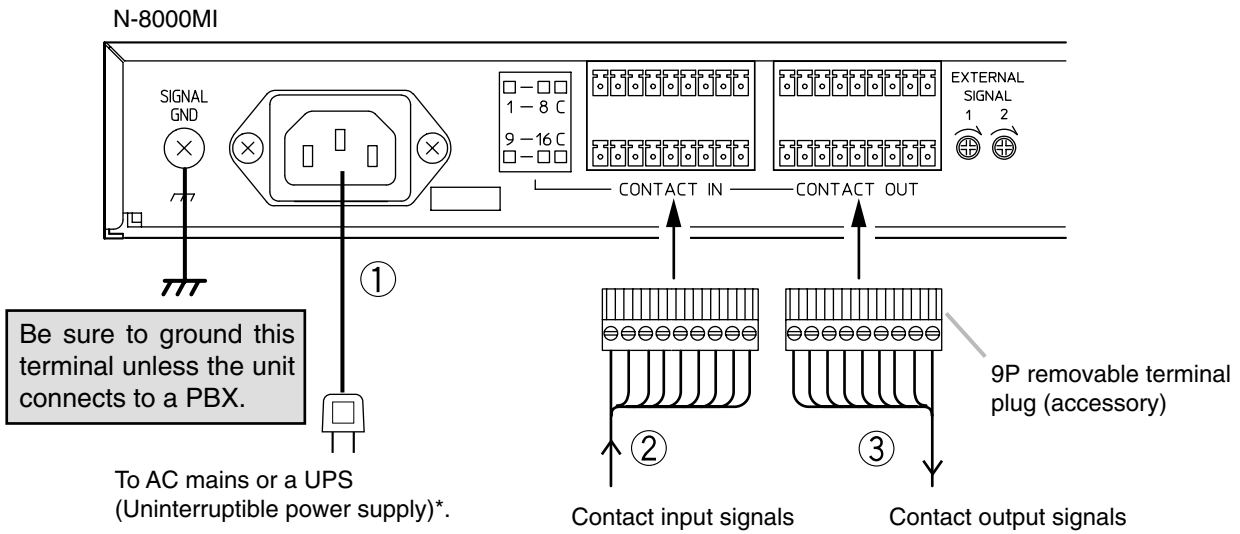

**Note**  
If there is a danger of lightning strikes, insert an appropriate surge arrester into the power line.

### [General description of connection]

For cables, refer to p. 11.

#### 1. Power supply connection

Connect the supplied power supply cord to AC Mains or a UPS (Uninterruptible power supply).

#### About power supply cord handling

The supplied power supply cord is designed for exclusive use with the N-8000MI. Use the supplied power supply cord only with the N-8000MI.

#### 2. Contact input terminal connection

(Refer to p. 12, Connector connection.)

#### [Specification of no-voltage make contact input]

Short-circuit current: 10 mA

Open-circuit voltage: 12 V

#### 3. Contact output terminal connection

Contact output terminals have no polarity. (Refer to p. 12, Connector connection.)

#### [Specification of relay contact output]

Withstand voltage: 24 V DC

Control current: Max. 0.5 A

\* Select an appropriate UPS taking into consideration the total power consumption of all system components and the required backup time, and also the requirement that the UPS should employ the on-line power system.

#### Reference

Multi Inertface Unit: Maximum 19 W.

8-Port 10M/100M Switching Hub: 10 W (Differs depending on products.)



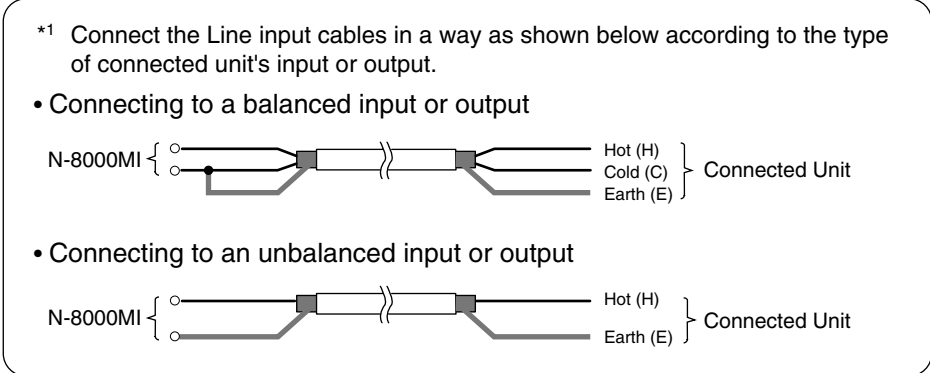
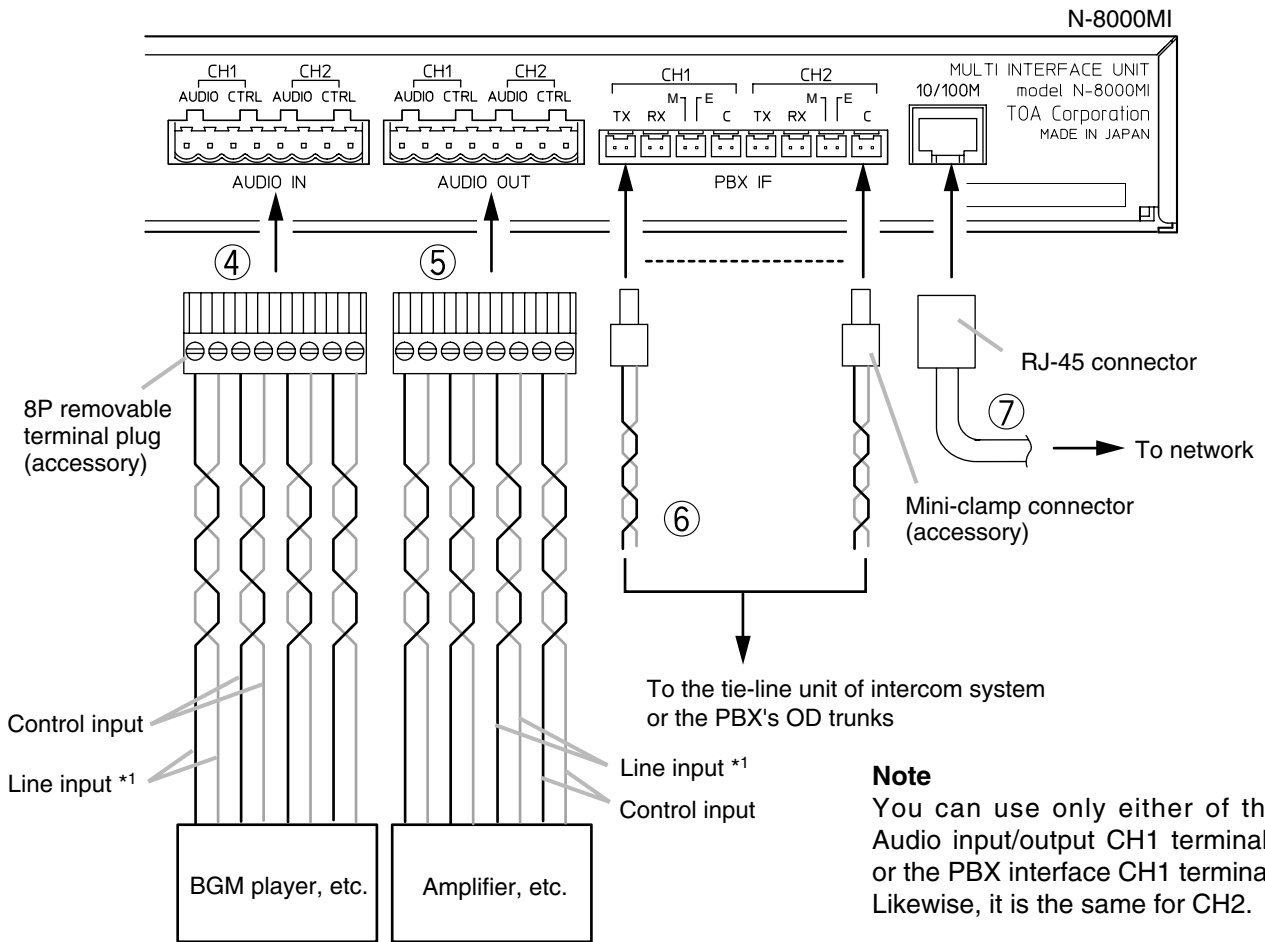

**4. Audio input terminal connection**  
Audio input terminals have no polarity.  
(Refer to p. 12, Terminal plug connection.)  
**[Specification of audio input]**  
Max. 0 dB\*2, over 10 kΩ, balanced  
**[Specification of control input]**  
No-voltage make contact  
Short-circuit current: 10 mA  
Open-circuit voltage: 12 V

**5. Audio output terminal connection**  
Audio output terminals have no polarity.  
(Refer to p. 12, Terminal plug connection.)  
**[Specification of audio output]**  
Max. 0 dB\*2, under 600 Ω, balanced  
**[Specification of control output]**  
Relay contact  
Withstand voltage: 24 V DC  
Control current: Max. 0.5 A

**6. PBX interface terminal connection**  
Differs depending on the connections to the Exchange of the EXES-2000 or EXES-6000 by a tie-line, or to the PBX exchange via the OD (out-band-dialing) trunk.  
(Refer to p. 11, Connector connection.)

**7. Network connection**  
Can be connected to a network of 10BASE-T/100BASE-TX in auto-sensing.  
Use a UTP category 5 straight-through cable for this connection.

\*2 0 dB = 1 V

**[Connecting to the PBX's OD trunk]**

Connect the PBX's transmitting line to the unit's RX terminal, and the PBX's receiving line to the TX terminal. Also connect the PBX's M (Mouth) line to the unit's E (Ear) terminal, and the PBX's E line to the M terminal.

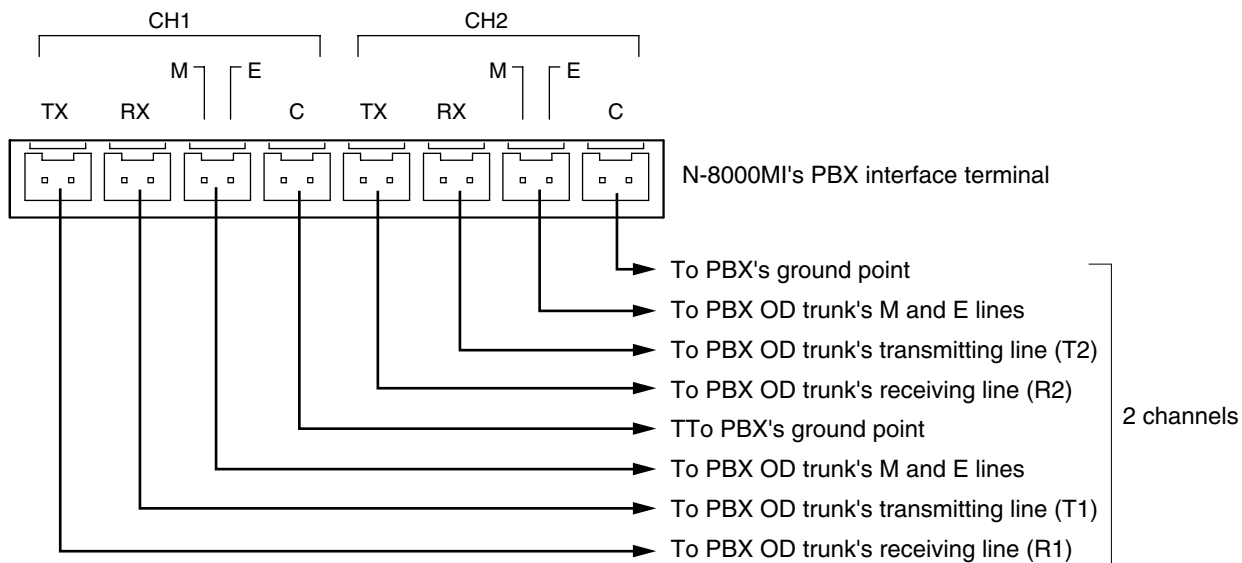

**Note**

Do not ground the Functional earth terminal (No. 6 on p. 5) in this PBX connection.

**[Connecting to the Intercom's Tie-Line Unit]**

Connect the intercom's transmitting line to the unit's RX terminal, and the receiving line to the TX terminal.

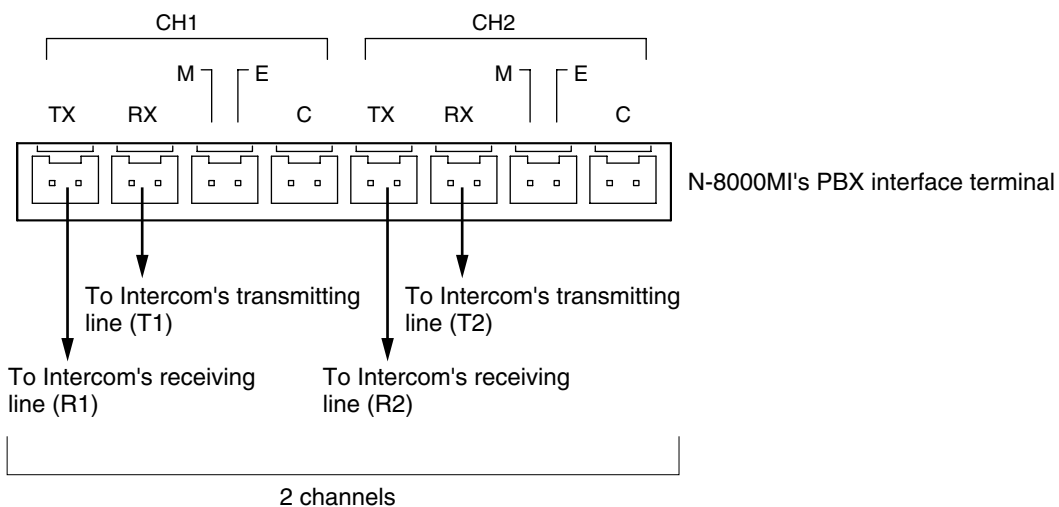

## 8.2. Type of Cable

The types of cables are to be determined according to the following conditions.

- Twisted pair wires (such as those used for electronic push-button telephone) are to be used for wiring to the audio input/output terminals and PBX interface terminal.
- UTP category 5 Straight through cables with RJ45 connector are to be used for wiring the equipments connected to IP network.
- The number of cables pairs laid should be determined considering the possibility of future expansion of the system.
- Outdoor wires should be used where wiring passes through inaccessible areas such as ceilings or under floors where the maintenance is not performed. Indoor wires may also be used, however, in case where there is no risk of deterioration due to exposure to heat, etc.

### Note

Specifications related to each junction are as follows.

Mini-clamp connector (PBX interface terminal)

Conductor diameter:  $\varnothing$  0.4 – 0.65 mm (AWG22 – 26), Solid wire

Outside diameter:  $\varnothing$  1.05 mm or below

Removable terminal plug (Control input/output terminals and audio input/output terminals)

Conductor diameter:  $\varnothing$  0.5 – 2 mm (AWG12 – 24), Solid wire/Stranded wire

## 8.3. Connector Connection

Mini-clamp connectors for PBX interface terminals and removable terminal plugs for line input and output terminals are supplied with the N-8000MI.

Perform each connector connection as follows.

### 8.3.1. Mini-clamp connector connection

**Step 1.** Cut off two-cable ends in equal length, and insert them securely to a cover section (transparent side) of the mini-clamp connector.

#### Note

Insert the cable without stripping the cable jacket.

For cables, refer to the above section, Type of Cable.

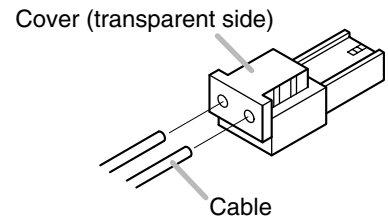

**Step 2.** With a pair of pliers, lightly pinch the mini-clamp cover and, after ensuring that the cable is securely inserted, firmly squeeze on the cover.

#### Note

Squeeze on the mini-clamp cover until it is correctly locked.

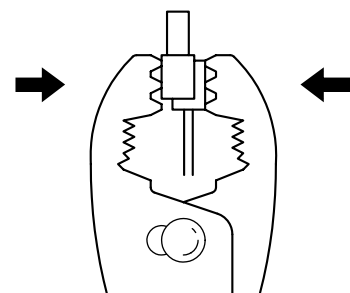

**Step 3.** Insert the wired plug into the N-8000MI's socket until it locks into place.

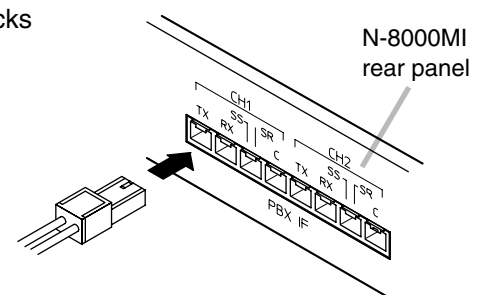

### 8.3.2. Terminal plug connection

**Step 1.** Strip a cable jacket of approx. 7 mm from the cable end.

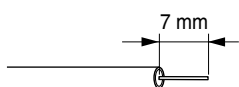

For cables, refer to p. 11, Type of Cable.

**Note**

Do not solder plate on exposed inner cables when using a stranded wire.

**Step 2.** Loosen the terminal screws and insert the cables.

**Step 3.** Tighten the terminal screws securely.

**Notes**

- Tug lightly on the cable to be sure that it does not pull free. If the cable pulls free, loosen the terminal screw again and reconnect from **Step 2**.
- Use the screwdriver appropriate to the screws tightened into the terminal plug.

**Step 4.** Insert the wired terminal plug into the terminal block.

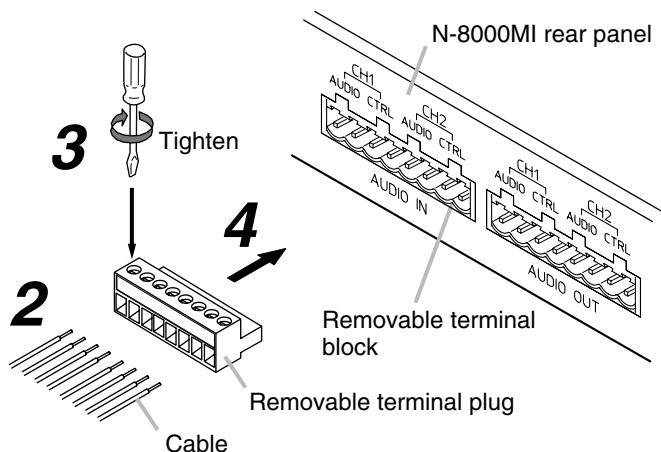

## 9. ACCESSORIES

AC power cord (2 m) .....	1	Machine screw M4 x 20 .....	4
CD* .....	1	Rack mounting bracket .....	2
Removable terminal plug (9 pins) .....	4	Tapping screw 3 x 8 .....	8
Removable terminal plug (8 pins) .....	2	Rack mounting screw 5 x 12 with plain washer .....	4
Mini-clamp connector (2 pins) .....	10	Wall mounting bracket .....	2
Plastic foot .....	4	Wooden screw 3.5 x 20 .....	4

\* Contains the N-8000 setting software program and the N-8000 series instruction manual. The Setup Launcher is automatically started when the supplied CD-ROM is inserted into the PC's drive.

**Note**

If your PC's CD drive is not compatible with the AutoRun function, the setup guide is not automatically started even when the CD is inserted. Use either "Explorer" or "My Computer" to execute the following files, or use [Start → Run] in the Task Bar and enter the following command.

<Drive where CD is placed> \index.html

For example, when placing the CD in the "d" drive, → d:\index.html

### Version update information

- Download our TOA Products Data, web site (<http://www.toa-products.com/international/>) to get the up-to-date version for N-8000 software, firmware, and Instruction manuals.
- The software version number can be confirmed using the Help menu.
- The current firmware version can be confirmed on the system management screen displayed when the browser establishes the connection to the Multi Interface Unit.
- The instruction manual version number can be confirmed by checking the preparation date (month and year) shown at the lower right corner of the last page.  
Example: Prepared in November 2004: 200411