



MONITOR SPEAKER

ME-160/ME-120

Delivering accuracy and musicality

safe&sound



Delivering accuracy and musicality

Designed to fulfill the demanding requirements for accurate and low-colouration monitor speakers for nearfield monitoring applications in control rooms, TOA's new ME-160 and ME-120 monitor speakers set a new level of excellence for applications requiring optimal sound quality whether professional or consumer.

Ideal for mixing and evaluating sound quality

Both the ME-160 and ME-120 are capable of producing a spacious, deep soundstage with outstanding ambience retrieval. Notable are the excellent low-level dynamics and resolution that facilitate effective monitoring. In most environments where monitoring program playback is important, nearfield monitoring is an ideal method as it minimizes room acoustic effects and other problems of the location while offering a useful sound quality evaluation tool for professionals as well as significant musical enjoyment for any listener. Flat frequency response and high resolving power make these speakers exceptional transducers. Shielded construction allows positioning of the speakers close to video monitors and CRT displays for audiovisual applications. Compact and easy to position in various locations with specialized hardware, the ME-160 and ME-120 are supplied as mirror-imaged pairs in single cartons.

Quality construction throughout.

Speaker cabinets are constructed from MDF (Medium Density Fiberboard) and the interior reinforced for maximum rigidity. On the back panel, gold-plated input terminals also accept dual banana jacks. The removable grilles feature acoustically transparent thin black jersey material.

Diverse installation possibilities

Versatile installation possibilities are possible with optional metal hardware for securing speaker on the base or side. Speakers can also be suspended from a wall or ceiling.



ME-160

ME-160 - dedicated features

- The woofer in the ME-160 utilizes newly developed composite cone material that incorporate natural fibers and resin to achieve an ideal stiffness, helping to generate an optimal piston motion.
- The soft fabric (Tetoron) dome tweeter utilizes an acrylic-based damping process in order to produce smooth, uncoloured and extended high frequencies.
- The ME-160 is a time-aligned speaker system so that all the sounds from the speaker reach the listener at the same time. This allows the speaker to achieve the best possible imaging with phase coherency.
- The crossover has been designed with specially selected components to ensure excellent transient response with minimal smearing and phase problems. The crossover undergoes a rigorous testing program that included listening evaluations in order to design a crossover that would obtain the best possible performance from the drivers.
- The speaker's high efficiency design partners the carefully designed combination of driver units and passive crossover components to achieve a flat frequency response over the useable frequency range, making the ME-160 a valuable tool in sound production tasks.
- The bass reflex cabinet design results in a tuning frequency of 50Hz for accurate low frequency reproduction within design parameters.

ality.



ME-120

ME-120-dedicated features

- Its smaller dimensions are optimized to house a single high-performance full-range driver unit that performs as a point source for the best possible dispersion.
- The single drive unit in the ME-120 makes good use of the natural material Chitosan in the cone material.
- Coupled with a copper ribbon edge-wound speaker voice coil, the ME-120 produces a magnetic flux density of 1.3T with its single driver delivering accurate low frequency energy within its range and allows the driver to extend its midrange frequency reproduction capability as well.
- Wide usable frequency range and superb balanced sound belies the ME-120's diminutive size and offers reproduction that is highly accurate and precise, making it a superb sound monitoring tool for various applications.
- The bass reflex cabinet design results in a tuning frequency of 75Hz for accurate low frequency reproduction within design parameters.

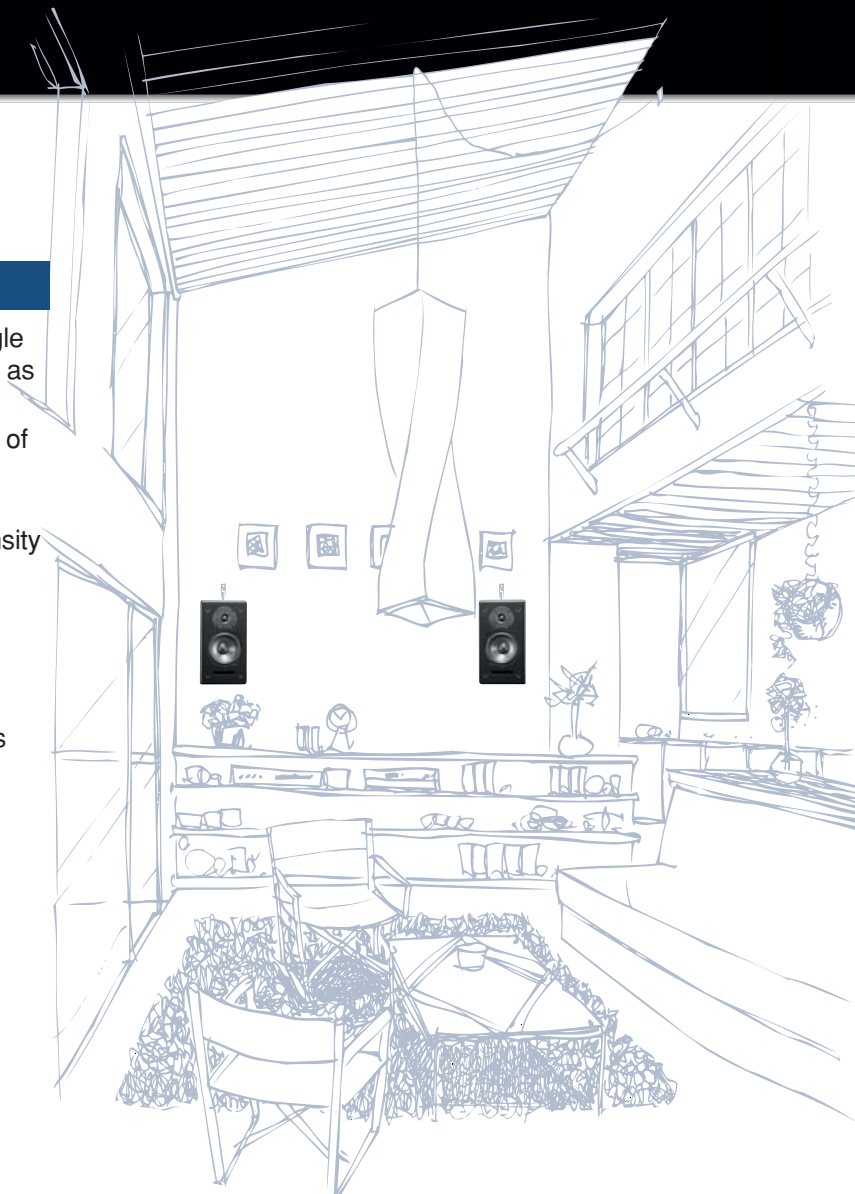



Rear



Rear

SPECIFICATIONS

	ME-160	ME-120
Enclosure		Bass reflex type
Power Handling Capacity		Continuous pinknoise: 50W, Continuous program: 150W
Rated Impedance		6 ohms
Sensitivity		88dB (1W, 1m)
Frequency Response	50 – 20,000Hz	60 – 18,000Hz
Crossover Frequency	2,000Hz	—
Speaker Component	16cm resin-impregnated natural fiber cone woofer (magnetically shielded) 2.5cm soft-dome type (magnetically shielded)	12cm cone-type (magnetically shielded) —
Input Terminals	Screw terminals (compatible with a dual-banana plug), gold plated	
Finish	Enclosure: MDF, black, paint Front grill: Cloth, black	
Dimensions	216 (W) × 376 (H) × 244 (D) mm	170 (W) × 264 (H) × 194 (D) mm
Weight	7.5kg (per unit)	3.6kg (per unit)
Mounting Brackets (option)	WCB-31, CMB-31	WCB-12, WCB-31, CMB-31

Note 1: Use screws inserted into an enclosure to mount the optional speaker holder.

Note 2: Both the ME-160 and ME-120 do not incorporate protective circuitry which could affect sound quality.

Care must be taken to pair the speakers with amplification within the recommended range. In no circumstances should the speakers be used for public address applications.

Optional Brackets

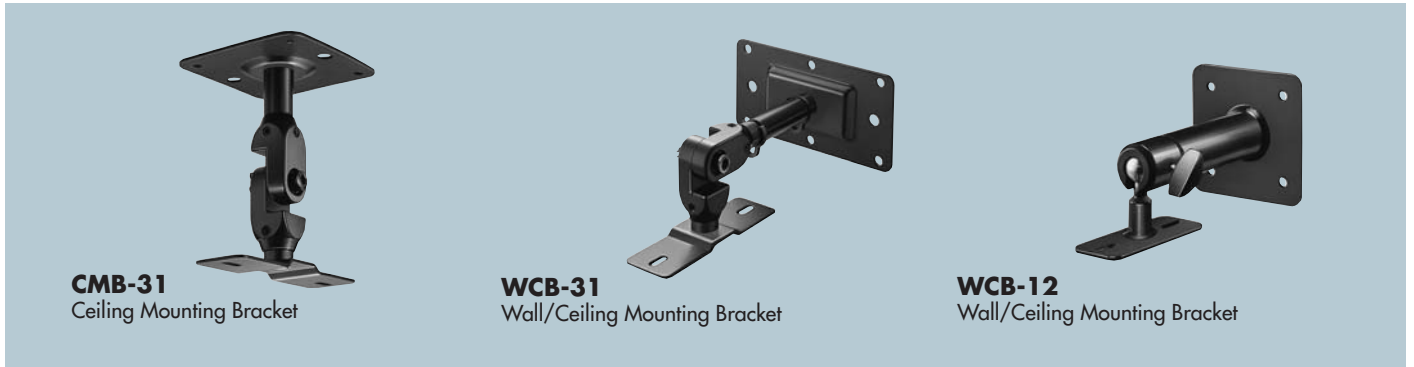

CMB-31
Ceiling Mounting Bracket

WCB-31
Wall/Ceiling Mounting Bracket

WCB-12
Wall/Ceiling Mounting Bracket