TOA INSTITUTIONAL COMMUNICATION SYSTEM

IC-100 Series

System Specifications



SYSTEM DESCRIPTION

The TOA IC-100 Series is a microprocessor-controlled, fully electronic institutional communication system specially designed to enhance administrative efficiency in schools, correctional institutions or other facilities.

The IC-100's modular construction and flexible configuration facilitate small-or large-system installation, maintenance, and system expansion from a single line card supporting one control station and up to 15 sub-stations, to 8 line cards for up to 8 control and 120 sub-stations per exchange, with up to 9 tie-lined exchanges per multi-exchange system. Using the optional CT-100, each exchange can have 2 outside lines, or a C/O line and a PBX extension. The IC-100 can also be connected to an external computer with the RS-232C port included on the MU-110 main control unit.

FEATURES

1. Modular construction for easy installation, maintenance and system expansion.
2. Exchange unit may be rack- or wall-mounted.
3. Flexible configurations are available for a variety of applications, from the smallest exchange configuration of 1 control station and up to 15 sub-stations, to up to 8 control stations, and 120 sub-stations per exchange.
4. Two (2) outside (C/O) telephone lines, or one each of C/O line and PBX (internal telephone) extension can be connected.
5. Tie-line capability, up to 9 exchanges, 72 control stations and 1,080 sub-stations.
6. RS-232C port for connection of a PC, for easy programming and system maintenance.
7. Eight speech links (4 through tie-line) for full-duplex or voice switch conversation.
8. Built-in programmable clock with 8 schedules x 32 events.
9. High fidelity Westminster Chime and 4-note chime.
10. Up to 60 (59 + all zone) zones can be established for paging, time signal and program source output functions.
11. Random paging, time signal and program source broadcast program for up to 10 sub-stations, 9 zones or 9 combination zones
12. External PA paging capability.
13. Convenient call forwarding, speed dialing, redialing, call transfer, conference and transfer functions.
14. 5 calling priorities available.
15. 12-digit LCD display for calling/called numbers, time functions, programming verification and sub-station mode.
16. Call queuing for up to 120 stations.
17. Message display on control station LCD display and an external display.
18. Control station Duress Alarm.
19. Sub-station emergency status call.
20. Arbitrary stations can be assigned to each zone at random.

IC-100 SERIES EXCHANGE & STATIONS

1. MAIN SYSTEM EQUIPMENT

CK-100B Card Case

The CK-100B houses all system boards and can be installed in an "EIA standard 19" rack.

MU-110 Main Control Unit

The MU-110 Main Control Unit uses a Z80 CPU to automatically control speech path switching functions upon reception of either a dial signal from the control station or a "call" or "privacy" signal from any of the connected sub-stations. The MU-110 also generates time-programmable signal tones. It provides external input/output controls and a computer communication capability via its RS-232C port. The MU-110 also provides the circuitry necessary to interface the DI-100/DI-110 boards.

LU-100 Line Unit

The LU-100 contains interface circuitry for control station connection, relay and talk-back, hybrid circuitry for sub-station connection, and a speech path switch. The control station interface outputs a dial signal to the Main Control Unit when it receives a control station dial signal. Other control station functions include FM signal demodulation, sound amplification and power supply control for control station and sub-station speaker talk-back capability. One control station and up to 15 sub-stations can be connected per Line Unit. The sub-station interface features an AGC-equipped 15W power amplifier (25V line) for sub-station speaker talk-back, relayed switching of up to 15 sub-stations, photocoupled reception of "call" and "privacy" signals, and hybrid circuitry for sub-station handset operation.

LU-200 Line Unit

The LU-200 contains interface circuitry for a control station, and a speech path switch. Control stations include FM signal demodulation, sound amplification, and talk-back capability. Only one control station can be connected per LU-200.

PS-100 Power Supply Unit

The PS-100 receives AC power from the PU-200 Power Transformer Unit, and provides 5V, 15V and 24V DC power to all other boards in the exchange via its rectification and stabilizer circuitry. DC input is also provided for an optional standby battery and charging circuit, that ensures full operating capability in case of a power failure.

PU-200 Power Transformer Unit

The wall-mountable PU-200 provides two 20V/2A AC outputs to the PS-100 Power Supply Unit to drive up to four LU-100 Line Units. A maximum of two PU-200s can be connected to the PS-100.

2. OPTIONAL SYSTEM EQUIPMENT

CT-100 Telephone & Tie-Line Unit

The CT-100 Telephone & Tie-Line Unit functions as an interface for both an outside telephone line and an exchange tie-line. Its C/O telephone line interface is compatible with both loop and ground start systems. It uses DTMF dialing signals for each of its 2 outside lines, or one C/O line and one PBX extension. The CT-100 complies fully with FCC Parts 68 regulations. The tie-line interface permits interconnecting of up to 9 exchanges, with 4 voice paths, 1 program I/O, and 1 control I/O.

DI-100/DI-110 Interface Boards

The Interface Boards allow a control station operator to make or receive calls from other stations via a single switch on a custom or off-the-shelf control panel. Calls to or from corresponding sub-stations can be announced by flashing LED's on the control panel, or by numbers shown on the displays of associated AS-100A or AS-110 control stations.

PN-100 Rack Mount Panel

The PN-100 provides side-by-side rack mounting capability for up to two PU-200 Power Transformer Units.

YC-300 Wall Mounting Frame

The YC-300 is used to mount the CK-100 Cards Case to a wall surface.

3. MASTER CONTROL AND SUB-STATION CONTROL

AS-100A Control Station

The AS-100A Control Station provides full-duplex communication with other control stations and sub-stations via its handset unit. It also features "hands free" communication, and a 12-digit display of the contacting/cd room number, the dialed number, sub-station priority status, a digital clock, and other indicators. The AS-100A utilizes a 4-pin modular telephone connector.

AS-110 Control Station

A flush-mount version of the AS-100A, this control station can be mounted in a console or on a wall.

RS-100 Switch Panel

The RS-100 Switch Panel mounts two switch buttons, a red "call" button and a white "privacy" button, to control an RS-110 Handset or a remote speaker. This flush-mount panel can be installed in a standard 1-gang electrical box and connected via a single-pair shielded cable.

RS-110 Sub-Station Handset

The RS-110 Sub-Station Handset provides full-duplex communication with the Control Station. The wall-mount cradle can be installed in a standard 2-gang electrical box and connected via a single-pair shielded cable.

RS-150 Economy Sub-Station

The RS-150 Economy Sub-Station includes a heavy-duty faceplate, call switch, loudspeaker and matching transformer.

RS-160 Indoor Sub-Station

The RS-160 Indoor Sub-Station includes a heavy-duty faceplate, vandal-resistant call switch, loudspeaker and matching transformer.

RS-170 Outdoor Sub-Station

The RS-170 Outdoor Sub-Station is weather-resistant and includes a heavy-duty faceplate, vandal-resistant call switch, loudspeaker and matching transformer.

RS-180 Panic Sub-Station

The RS-180 Panic Sub-Station is weather-resistant and includes a heavy-duty faceplate, vandal-resistant call switch, loudspeaker, matching transformer, red call LED, red call button and control output.

FUNCTIONS

1. Conversation

Call from a Sub-Station

Pressing the RS-100 switch panel CALL switch or picking up the sub-station handset initiates a call-in to the control station, indicated by a flashing LED on the switch panel.

Pressing the PUSH-TO-TALK switch or picking up the AS-100A or AS-110 control station handset enables conversation, with the LED indicator fully on. Conversations through the sub-station speaker are automatic half-duplex with the voice switch and manual half-duplex with the PUSH-TO-TALK switch. Sub-station handset conversations are full-duplex, converting to half-duplex when the PUSH-TO-TALK switch is used.

The LED indicator goes off at the end of a conversation.

Pressing the CALL switch continuously for more than 3 seconds initiates an emergency call to the control station, setting off the emergency status display at the control station.

Call from a Control Station

Dialing a station number with the keypad initiates a calling tone and sets up a voice link. Hands-free conversation is half-duplex when the PUSH-TO-TALK switch is used, and automatic with the voice switch.

Pressing the [#]/C key or replacing the handset terminates the conversation.

2. Display

The AS-100A/AS-110 control station is equipped with a 12-digit LCD display for the calling party's station number and priority level, or the numbers of the stations on hold. Holding station capacity is 120 per system. Current time, control station privacy status, time schedule status, sub-station mode display or a message from a personal computer can be displayed while the control station is on-hook (in idle status).

3. Privacy

Pressing the RS-100 switch panel PRIVACY switch puts the sub-station in privacy mode and causes the privacy LED to go on. In privacy mode, incoming calls are refused. The sub-station can still be called, but sub-station conversations cannot be heard. Pressing the switch again cancels the privacy mode. Pressing the [*] key on a control station twice puts it into privacy mode, causing incoming calls from other control stations to be refused. Pressing [*] and [#]/C cancels the privacy mode.

4. Alert Tone

While a control station and a sub-station are connected, a periodic alert tone can be sent to the stations to prevent sub-station conversations from inadvertently being overheard by the control station.

5. Time-Out

Conversation, sub-station calling, paging and PBX conversation can be automatically reset within a programmable time frame.

6. Priority

Five levels of priority can be established for all individual station calls, displayed in the following order: (1) Emergency (2) Priority (3) Alarm (4) Normal (5) Staff.

7. Paging

Sub-Station Paging

Permits simultaneous paging of up to 10 individual sub-stations.

Zone Paging

Permits simultaneous paging of pre-programmed combinations of sub-stations in zones. Up to 60 zones (59 zones + all zones) can be established, regardless of the number of tie-lined exchanges.

Combination Zone Paging

Permits simultaneous paging of pre-programmed combinations of zones. Up to 9 combinations can be established, regardless of the number of tie-lined exchanges.

All-Call Paging

Permits simultaneous paging through all the stations assigned to all zones and external PA speakers.

Emergency All-Call Paging

Takes precedence over all other functions to permit simultaneous paging through all the stations assigned to all zones and external PA speakers assigned to all-call.

External Microphone All-Call Paging

All-Call paging can be performed from a connected external microphone after activation with an external switch.

PA Paging

Permits All-Call or zone paging through a connected external PA system. An auxiliary selection device can control PA zone selection output, making up to three different PA zones possible.

8. Program Source Output

Permits broadcast of a selectable program source to individual sub-stations, zones, combination zones and all zones.

9. Time Signal

Permits broadcast of time signals to individual sub-stations, zones, combination zones, and all zones. Time signals can either be automatically output at preset times using the system's programmable clock, six external time signal trigger inputs, or manually output from a control station. The programmable clock permits programming of 8 separate 32-event schedules.

Schedules can be selected at the control station. Built-in time signals are (1) an FM quality, high-fidelity generation of the Westminster Chimes, and (2) a 'trill tone'. Provision exists for input of up to 3 alternate, user-supplied tones. An external bell relay can be driven either by itself, or in conjunction with any tone or tone input.

10. Call Transfer

Calls between control stations or to a sub-station can be transferred to a third station.

11. Call Forwarding

All calls to a control station can be automatically forwarded to any other locally pre-designated control station. This function can also be used to forward calls to/from the external C/O telephone lines.

Auto-Call C/O Transfer

This function permits handset sub-station calls to a control station registered for this function to be automatically forwarded to a programmed C/O telephone number. The auto-call C/O transfer function can be operated in one of two ways, either directly by a control station, or by external make-contact inputs typically controlled by an external timer, etc.

Control Station Group Call (Selectable Function)

All control stations pre-programmed for the same group can be called simultaneously from a sub-station. Up to 8 groups of 8 stations each can be programmed.

12. Speed Dialing

Up to ten station, telephone or paging numbers can be registered for convenient speed dialing.

13. Redialing

The last number dialed at a control station can be automatically re-dialed with a touch of the REDIAL key.

14. Conference

Calls can be made from a control station to up to two other control or sub-station numbers.

15. External Telephone (C/O) Line Communication

Up to 2 external telephone lines can be connected to the exchange via the CT-100 C/O & Tie-Line Unit. External-line incoming or outgoing call capability can be independently assigned to all control stations

PBX Extension Communication

All stations can access the PBX using the CT-100 C/O & tie-line card. The CT-100 features two outside C/O line terminals which can be registered for either C/O line or PBX extension use by system programming. Only one outside C/O line terminal may be connected to the PBX extension

16. Personal Computer Connection

The exchange can be connected to an external personal computer via the RS-232C connector attached to the MU-110 Main Control Unit. System programming and maintenance can then be easily performed at the computer's keyboard, with password protection.

17. Message Display

Messages input at the connected computer can be output at the control station LCD display, and acknowledgments in turn displayed on the computer monitor.

18. Tie-Line Connection

Up to 9 exchanges can be interconnected using the CT-100 C/O & Tie-Line Board to provide extended communication capability to a maximum of 72 control stations and 1,080 sub-stations. The maximum number of 60 programmable zones and 9 combination zones remains limited to 9 each, regardless of the number of interconnected exchanges

19. Duress Alarm

The Control Station can be pre-programmed to automatically transmit an emergency status call to all other control stations when the handset is removed from the cradle and a call or page is not started within 6 seconds. The control station in emergency can then be called by another control station, whether or not the handset of the control station in emergency has been replaced.

20. Emergency Call

Any Sub-Station can be pre-programmed to automatically transmit an emergency status call to the designated control station when the "Call" button is pressed and held for three seconds.

21. Direct Select Interface

With the use of DI-100 or DI-110 Interface Boards, calls may be made or received from other stations at the touch of a single control panel switch. Call announcements are shown by flashing control panel LEDs or AS-100A/AS-110 alphanumeric displays.

22. Off-Hook Indication

Any RS-110 handset left off-hook after conclusion of the conversation will be indicated on the AS-100A/AS-110 LCD display.

23. Busy/Privacy Status Indication

The AS-100A/AS-110 LCD display will indicate the busy or privacy status of called stations.

24. Scan Monitor

Any control station can scan an arbitrary group of sub-stations (in consecutive order) for auditory monitoring of each sub-station at a pre-set time interval.

Main System Equipment

CK-100B Card Case

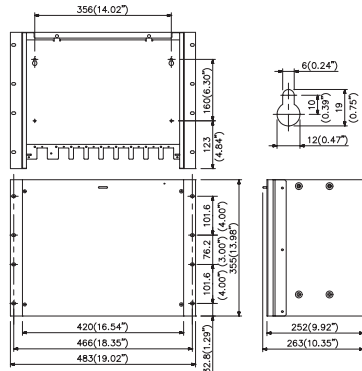
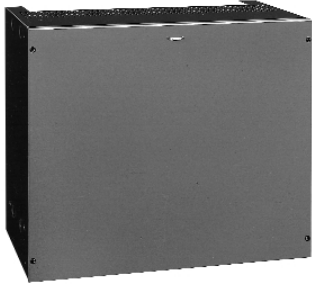

**YC-300 (optional)
Wall Mounting Kit for CK-100B**

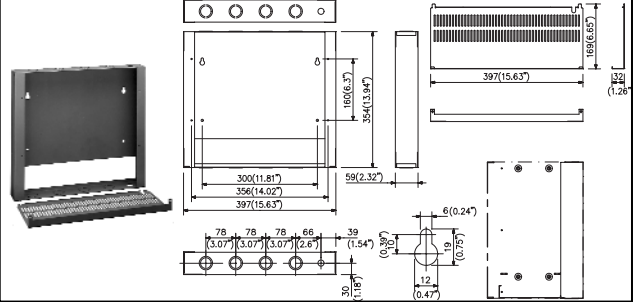

PU-200 Power Transformer Unit

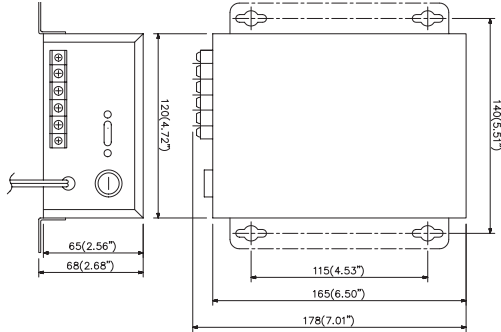

**PN-100 (optional)
Rack Mounting Panel for PU-200**

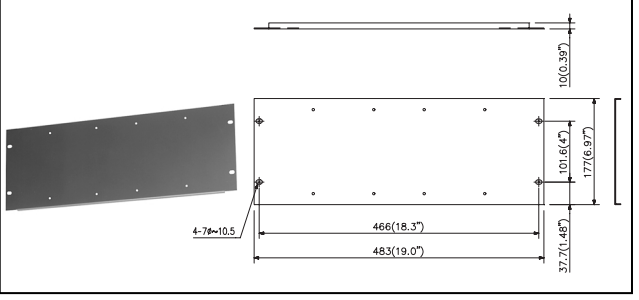

**MU-110
Main Control Unit**

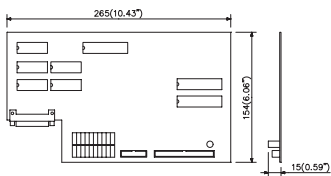
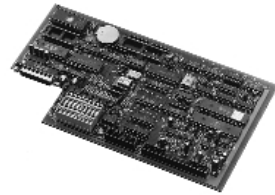

**LU-100
Line Unit**

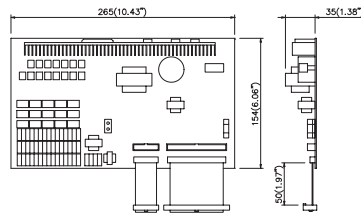
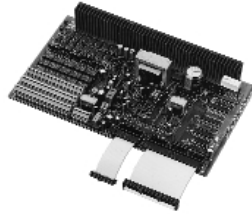

**LU-200
Line Unit**

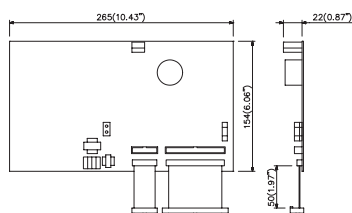
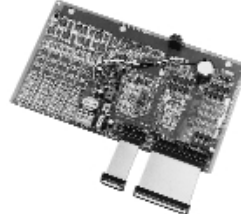

**PS-100
Power Supply Unit**

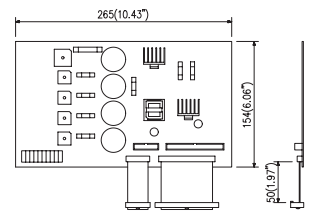
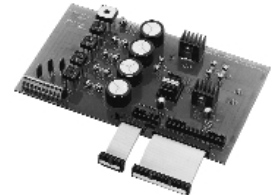

**CT-100
Telephone & Tie Line Unit**

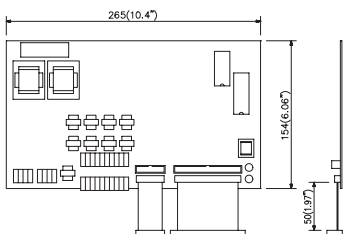
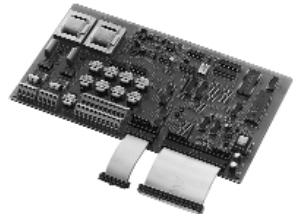

**DI-100
Interface Board**

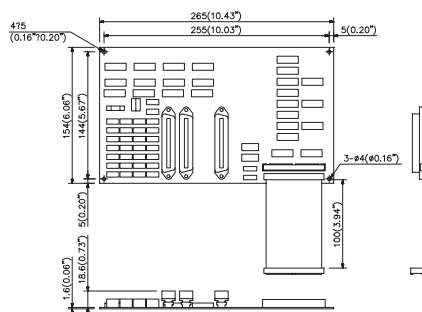

**DI-110
Interface Board**

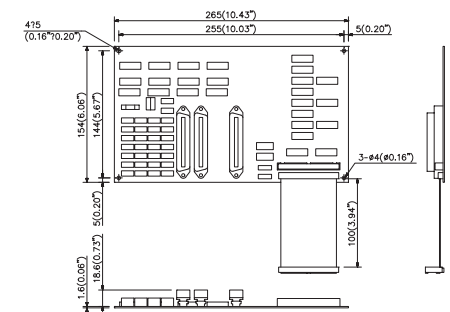

Master Control and Room Station Equipment

AS-100A
Control Station

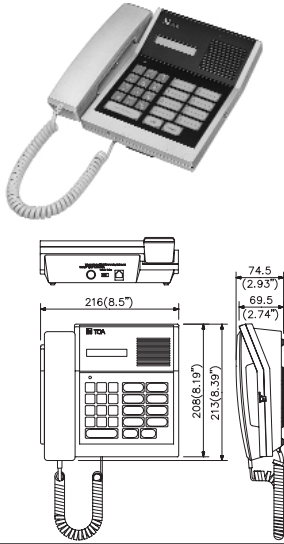

AS-110
Control Station

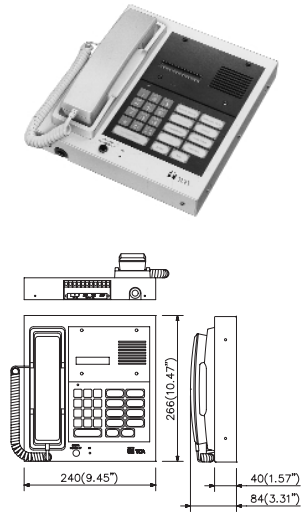

RS-100
Switch Panel

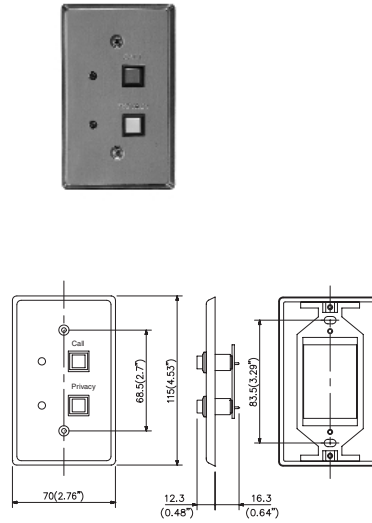

RS-110
Handset

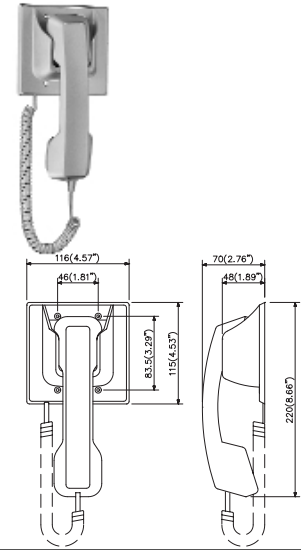

RS-150
Economy Sub-Station

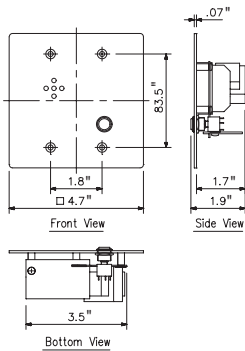

RS-160
Indoor Sub-Station

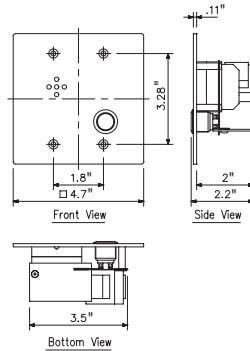

RS-170
Outdoor Sub-Station

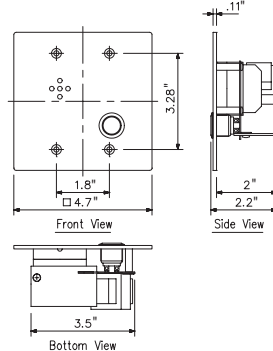

RS-180
Panic Sub-Station

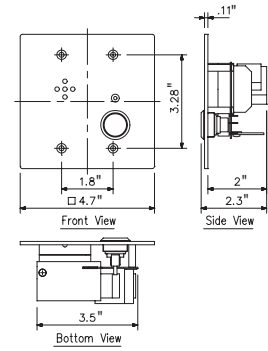

SYSTEM CONSTRUCTION TABLE

Sample System	SET 1	SET 2	SET 3	SET 4	SET 5
No. of Sub-Stations	1-15 max. (N)*1	1-15 max (N)*1	1-15 max (N)*1	1-60 max (N)*1	1-120 max (N)*1
No. of Control Stations	1 max.	1 max.	1 max.	4 max.	8 max.
C/O Lines	0	0	2 max.	2 max.	2 max.
Equipment:					
CK-100B	1	1	1	1	1
YC-300	0	1	0	0	0
PU-200	1	1	1	1	2
PN-100B	1	0	1	1	1
MU-110	1	1	1	1	1
LU-100	1	1	1	4	8
PS-100	1	1	1	1	1
CT-100	0	0	1	1	1
AS-100A or AS-110	1 max.	1 max.	1 max.	4 max.	8 max.
RS-100, RS-150/160/170/180	15 max.	15 max.	15 max.	60 max.	120 max.
Room Speakers	(N)	(N)	(N)	(N)	(N)

SET 1 15 sub-stations—Rack mounting type without C/O line

SET 2 15 sub-stations—Wall mounting type without C/O line

SET 3 15 sub-stations—Rack mounting type with C/O line

SET 4 60 sub-stations—Rack mounting type with C/O line

SET 5 120 sub-stations—Rack mounting type with C/O line

*1 N is the number of sub-stations

SPECIFICATIONS

Exchange Method	Space division
Control Method	Common stored program control
Call Method	Speaker-output call signal or voice
Conversation Method	Voice Switch or PTT-activated talk-back, or full-duplex handset communication
Dialing System	AM-modulated pulse number transmission (control station), and current loop transmission (sub-station) systems
Station Line Capacity	Max 8 sets of 1 control station & 15 substations per exchange
C/O Line Capacity (PBX Extension Capacity)	Max. 2 outside telephone (C/O) lines or one each of C/O line and PBX extension per exchange
Link Capacity	8
Station No. Schedule	No. 00-99 (2-digit) No. 000-999 (3-digit) No. 0000-9999 (4-digit)
Signal Tones	Call/Busy/Hold/Page/Time/(Others)
Wiring	Control station: 2 twisted pairs Sub-station: 1 twisted pair, shielded
Cable Length	Control station: 4,800 ft. (1,464m); 22AWG Sub-station: 2,800 ft. (854m); 22AWG
Speaker Output	1W (25V line)
C/O Line	Start signal: Loop or Ground start Dialing signal: DTMF
Tie Line	Link Capacity: 4 Connection: Multi-drop Number of lines: Voice lines—8 pairs Program lines—1 pair Data lines—1 pair
Power Requirements	AC MAINS 50/60Hz Backup battery: 24 VDC ± 10%
Power Consumption	Max.: 250W, (at All-call to 120 sub-stations) Min.: 40W, (at Stand-by configuration with 120 sub-stations)
Operating Temperature	32° to 104°F (0° to 40°C)
Dimensions (W x H x D)	14.0 x 16.6" x 10.4" (355 x 420 x 263mm)
Weight	35.3 lbs (16kg)
Case Material	Zinc-plated steel
Finish	Front panel: Noland Gray Enamel Case: Dark Gray Enamel

*Specifications are subject to change without notice.

SAMPLE SYSTEM CONFIGURATION

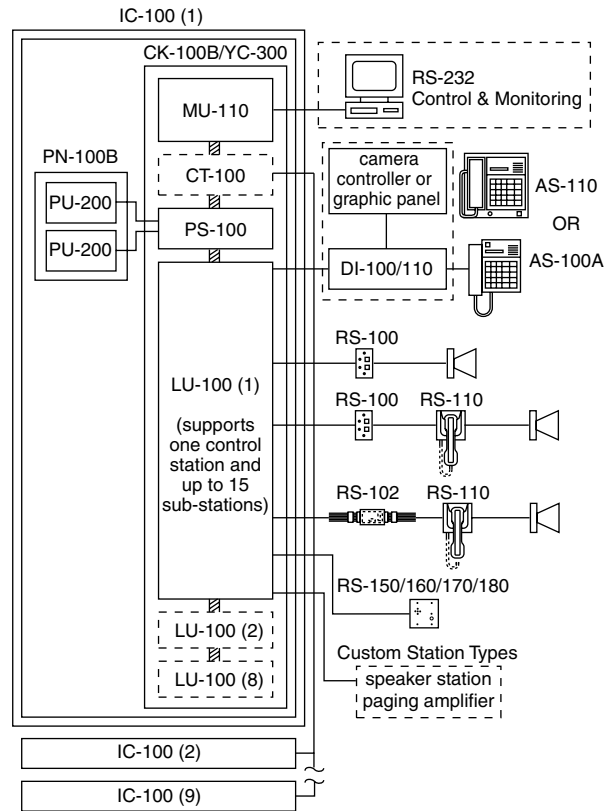

NOTE: [---] shows optional units used according to job requirements



TOA Electronics, Inc.

Phone: 800-733-7088 Fax: 800-733-9766

Web Site: www.toaelectronics.com

TOA Canada Corp.

Phone: 905-564-3570 Fax: 905-564-3569