



SOFTWARE INSTRUCTION MANUAL

DIGITAL PROCESSOR

DP-0206

DACsys2000

Version 2.00

Please follow the instructions in this manual to obtain the optimum results from this unit.
We also recommend that you keep this manual handy for future reference.

TOA Corporation

TABLE OF CONTENTS

1. Before installation	3
2. Installation method	4
3. Launching the application	8
4. Main window	9
5. Outline of the menu functions	10
6. Unit operation	13
7. Unit Viewer	18
8. Memory Viewer	20
9. Flow Viewer	21
10. Contents Viewer	23
11. Response Viewer	38
12. Preset Memory	41
13. Level Monitor Viewer	42
14. Mute All Window	43
15. Communications	44
16. User Level	46
17. Prohibition Settings	48
18. Print	50
19. Export	51
20. DQ-C01 Settings	52
21. Supplement	60
22. Specifications	62

1. Before installation

DACsys 2000 is software created to allow you to change settings for the DP-0206.

This setting software can be used in the following environments: Microsoft Windows 95/Windows 98/Windows ME/Windows NT Ver. 4.0/Windows 2000.

The format for the floppy disk is 1.44 megabytes (MS-DOS format for IBM compatibles).

Make sure your machine is an IBM compatible capable of formatting 3.5-inch floppy disks at 1.44 megabytes (MS-DOS format). This software will not operate on a machine that operates under a different format.

2. Installation method

There are two installation disks (labeled Disk 1 of 2 and Disk 2 of 2).

Proceed with installation as follows:

Be sure to close any applications that are running before beginning the installation process.

1. Click the  **Start** button on the screen and select Settings → Control Panel. The window shown at right will appear.

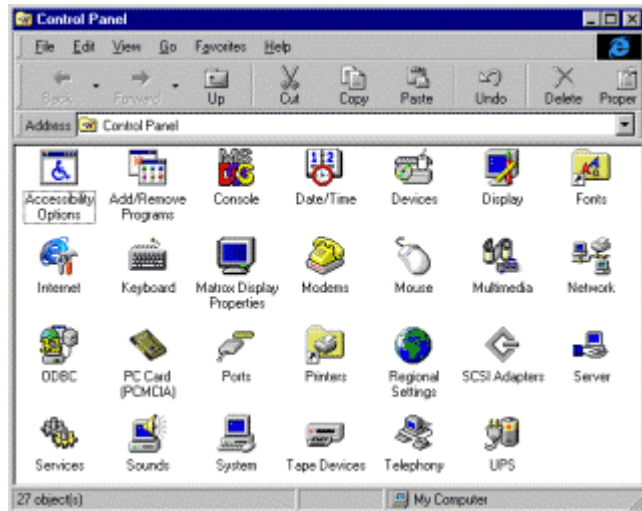

2. Double-click the icon  Add/Remove Programs in the Control Panel window to display the window shown at right.



3. Click **Install...**. The window shown at right will appear.



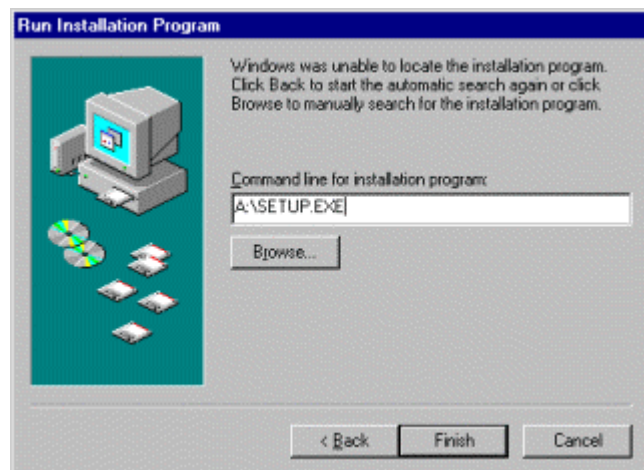

4. At this point, insert the system disk (Disk 1 of 2) in the floppy-disk drive and click **Next >**.

5. The system will search the setup program, and the window shown at right will appear. Then click **Finish**.

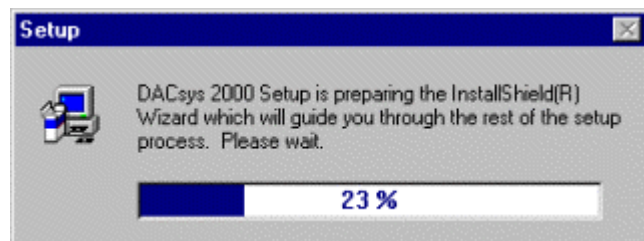

6. During the preparation for installation, the window shown at right will be displayed.



7. If the window shown at right appears, carefully read the information in the window and then click .



8. Carefully read the information in the window and then click .



9. If the window shown at right appears, remove the disk (Disk 1 of 2) from the drive and insert Disk 2 (Disk 2 of 2), then click "OK".

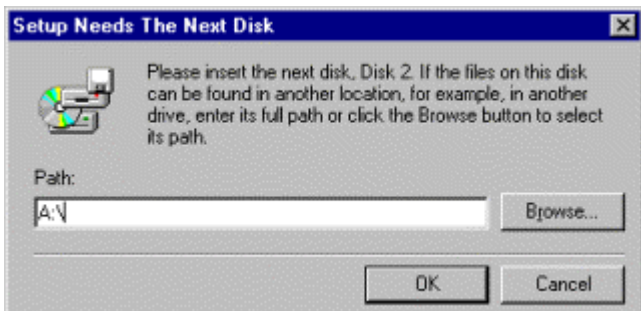

10. If the message indicating completion of setup appears, click



3. Launching the application

To launch the application once it has been installed, follow either of the two procedures described below:

1. Create a desktop shortcut and launch the application by clicking its icon.

Drag the icon DACsys 2000 (which will be displayed immediately when installation is completed) with the mouse while holding the Ctrl key pressed and drop it onto the desktop (to copy the icon). This will set it up as a shortcut on your desktop. Then launch the application by double-clicking this shortcut icon.



DACsys 2000

2. Proceed in steps from the Windows Start button.

Click  on the screen the select Program →TOA Digital Audio Control →DACsys2000 to launch the application.

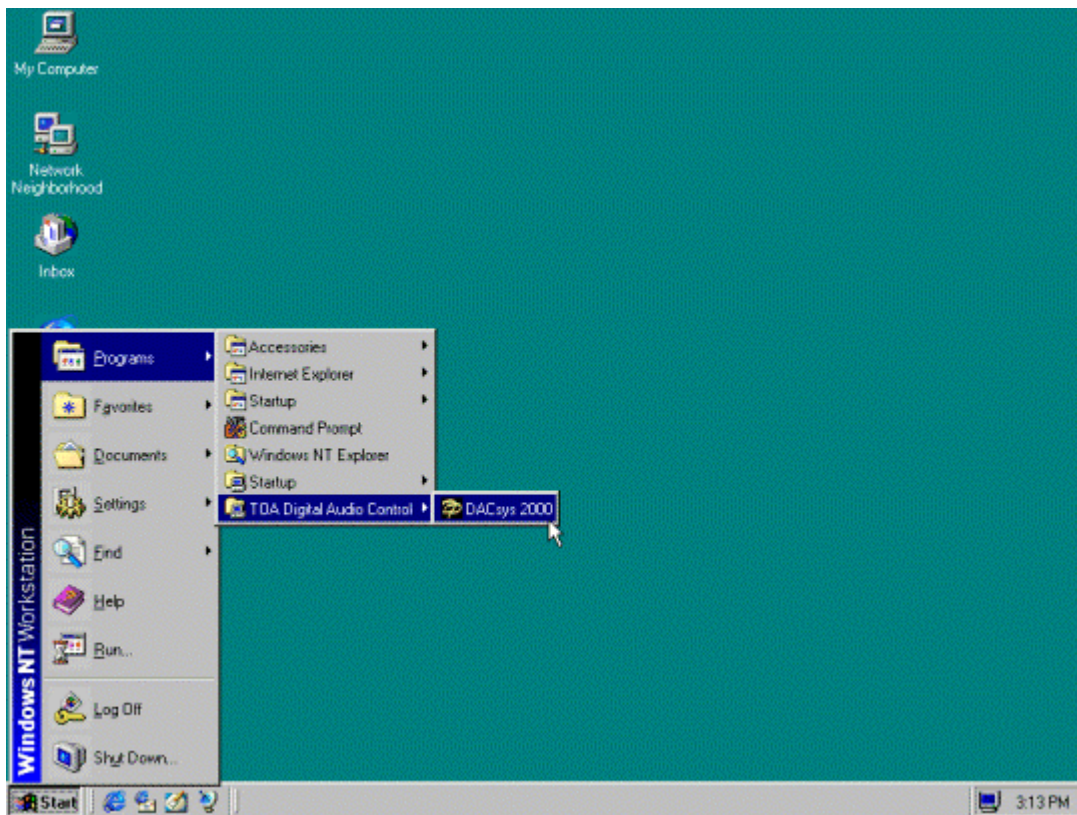

4. Main window

The window shown below will appear when the application is launched.

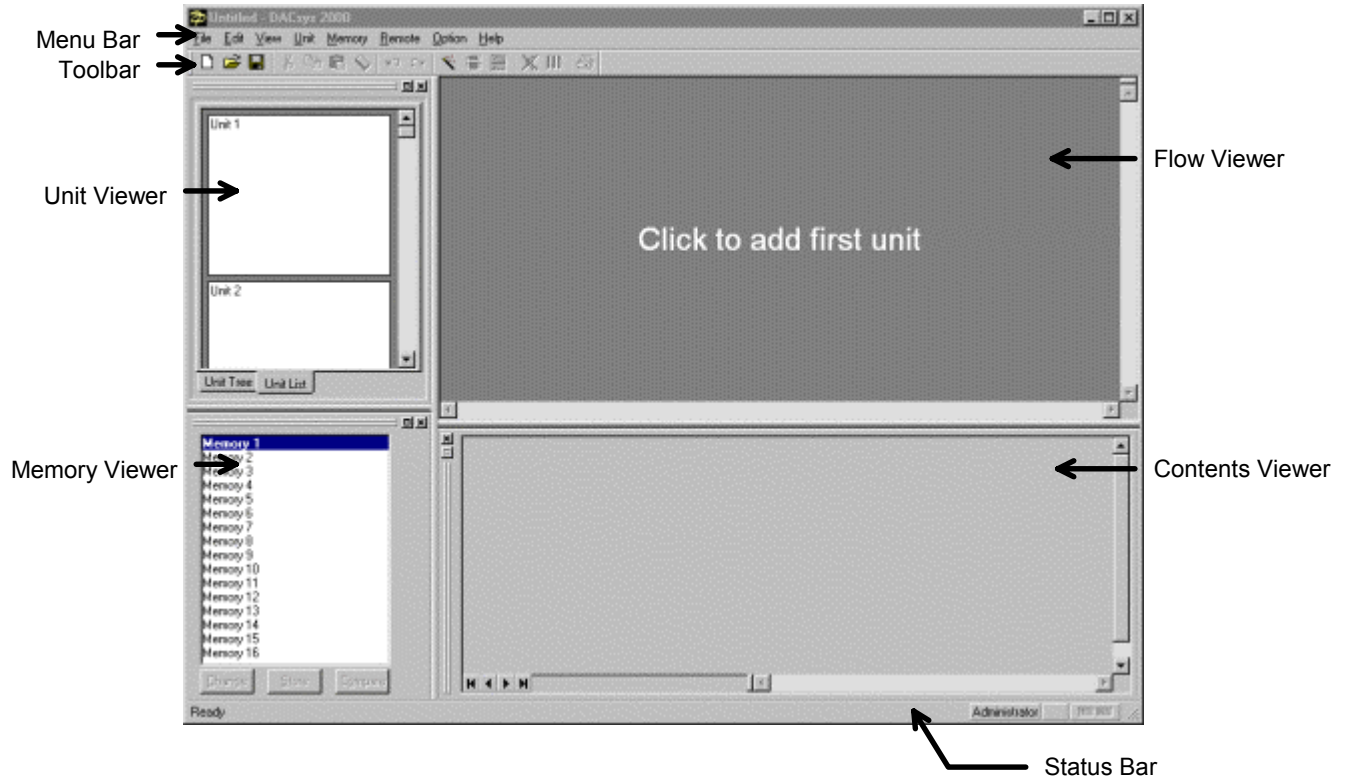

5. Outline of the menu functions

File

<u>N</u> ew...	: Creates (sets) a new data file
<u>O</u> pen...	: Opens an already existing data file
<u>S</u> ave	: Saves the data file in use on a disk
Save <u>A</u> s...	: Saves the data file in use on a disk under a different name
<u>E</u> xport...	: Exports the data of the active document as the Microsoft Excel data. The menu regarding the export appears only when the Microsoft Excel is installed in the PC.
Page Settings...	: Changes the print margin.
<u>P</u> rint...	: Prints the active document
Print <u>P</u> review...	: Displays full pages
<u>E</u> xit	: Closes the application

Edit

<u>U</u> ndo	: Undoes the last action
<u>R</u> edo	: Redoes the previously undone action
<u>C</u> u ^t	: Saves the setting value in the box in which the cursor is located on the clipboard and restores the initial value
<u>C</u> opy	: Copies the setting value in the box in which the cursor is located on the clipboard
<u>P</u> aste	: Pastes the data on the clipboard into the box in which the cursor is located
<u>C</u> lear	: Restores the setting value in the box in which the cursor is located to the default value
<u>S</u> wap Gain < - > C/G	: Makes the Gain and C/G boxes trade positions
<u>F</u> ilter Type	
→ <u>P</u> EQ	: Changes the box in which the cursor is located to a PEQ box (with the default setting for PEQ)
→ <u>G</u> EQ	: Changes the box in which the cursor is located to a GEQ box (with the default setting for GEQ)
→ <u>F</u> ilter	: Changes the box in which the cursor is located to a Filter box
<u>S</u> plit	
→ <u>P</u> EQ+Filter	: Filter is divided into PEQ and Filter
→ <u>G</u> EQ+Filter	: Filter is divided into GEQ and Filter
→ <u>F</u> ilter+Filter	: Filter is divided into Filter and Filter
<u>M</u> erge	: Unites with one Filter

- Set Grouping... : Creates a box group
- Release Grouping : Releases the boxes of the current group and cancels the group
- Write Protect to Box
 - Low : The operator is prohibited from changing of the parameter of Box
 - Mid : The operator is prohibited from changing of Box all
 - High : The change of the parameter in Box by Administrator is prohibited, and the operator is prohibited from changing all.

View

- Toolbar : Shows/hides the toolbar
- Status Bar : Shows/hides the Status Bar
- Unit View : Shows/hides the Unit Viewer
- Contents View : Shows/hides the Contents Viewer
- Response View : Shows/hides the Response Viewer(p. 38)
- Memory View
 - Show/Hide : Shows/hides the Memory Viewer
 - Floating : Floats the Memory Viewer
 - Docking : Docks the Memory Viewer
- Mute All
 - Show/Hide : Shows/hides the Mute All Window(p. 43)
 - Floating : Floats the Mute All Window
 - Docking : Docks the Mute All Window
- Level Monitor View : Shows/hides the Level Monitor Viewer

Unit

- Create New Unit... : Creates a new unit
- Delete Unit : Deletes the unit from the data file
- Change Unit Configuration... : Changes the number of inputs and outputs of existing units
- Change X-over
 - Combination... : Changes the combination of the crossover
 - Slope... : Changes the slope of the crossover
- Names... : Changes the names of the unit and the inputs and outputs
- Save as a Unit Template
 - Unit Template... : Saves the unit settings in a file as a template
 - X-over Template... : Saves the crossover settings in a file as a template

Memory

Change

→ Memory1 - 16 : Recalls a preset from one of the 16 preset -memory cells

Store

→ Memory1 - 16 : Stores the status in one of the 16 preset -memory cells

Names... : Changes the name of a memory cell

Remote

Connect... : Connects the PC with the unit to set online status

Disconnect : Breaks the connection between the PC and the unit for off-line status (any changes in settings made at the PC when off-line will not affect the unit's settings)

Bulk transmission... : The data of the file which is opening now is compelling transmitted

Bulk receiving... : All the data of the unit is received

Auto Connection... : Next time, when the file is opened, connects it automatically

Option

Security Settings... : Setting the user level and the prohibition setting of various operations are done.

External Control... : Makes the setting of the external control

Help

About : Displays the version of DACsys 2000

6. Unit operation

Creating a unit

1. Select from the menu bar Unit → New... to open the Unit Configuration window.

The screenshot shows the 'Unit Configuration' dialog box. It features a title bar with the text 'Unit Configuration'. Below the title bar, there are several input fields and options: a 'Name' text box, a 'Unit ID' dropdown menu currently showing '1 (Master)', a 'Create New' radio button which is selected, and a 'Number of I/O' section containing six radio button options: '2 x 6' (selected), '4 x 6', '2 x 8', '4 x 8', '2 x 10', and '6 x 6'. Below these options is a 'Create from Template' radio button and a 'File Path' text box with a browse button '...'. At the bottom of the dialog are three buttons: '< Back', 'Next >', and 'Cancel'.

2. In the Unit Configuration window, first input the name of the unit then select a unit ID.
3. Select the number of inputs and outputs from among 2 x 6, 2 x 8, 2 x 10, 4 x 6, 4 x 8, and 6 x 6. The initial value is 2 x 6. When using an already existing template file, select "Create from Template". You can directly input a filename, or you can make a selection from the dialog box, which can be displayed by clicking the **...** part.

4. Click "Next". The X-over Combination window will appear.

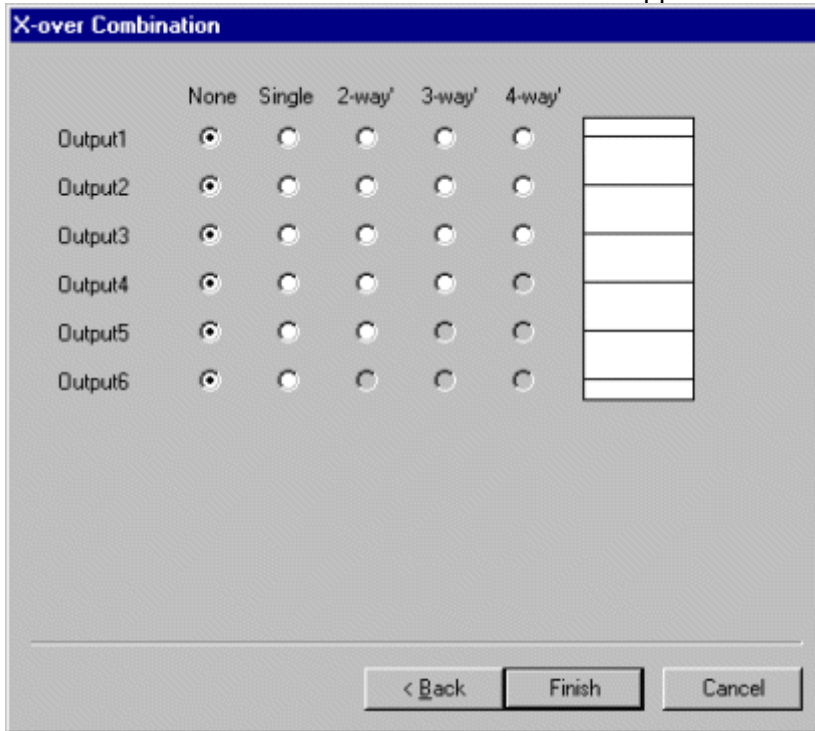

5. Make the crossover combination settings by first clicking the appropriate spaces. The setting status is displayed in the right-hand portion of the window. Below is an example of a 3-way/2-channel setup when 6 outputs are in use.

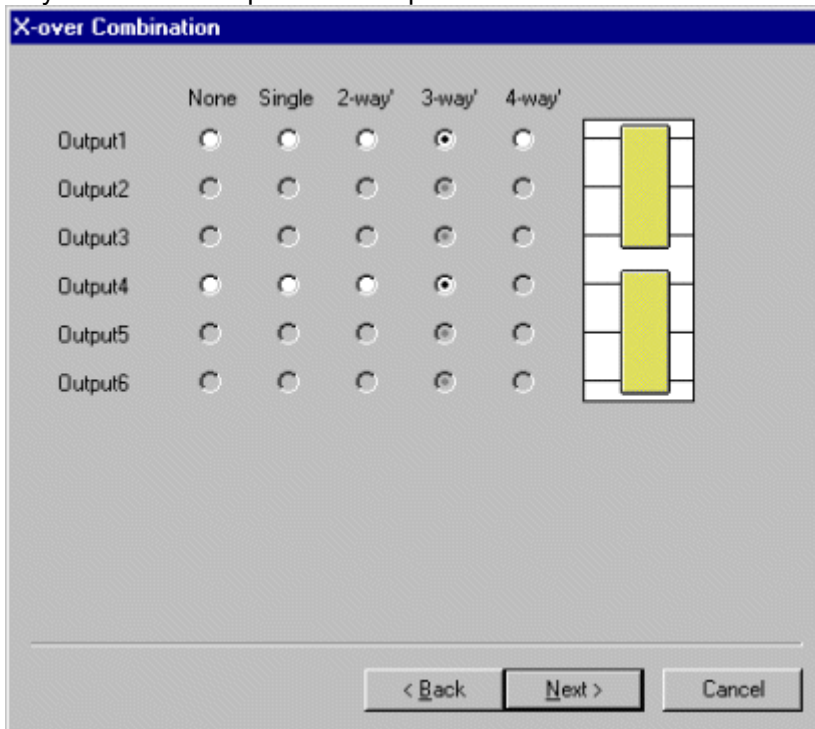

6. Click "Next". The X-over Slope window will then appear.

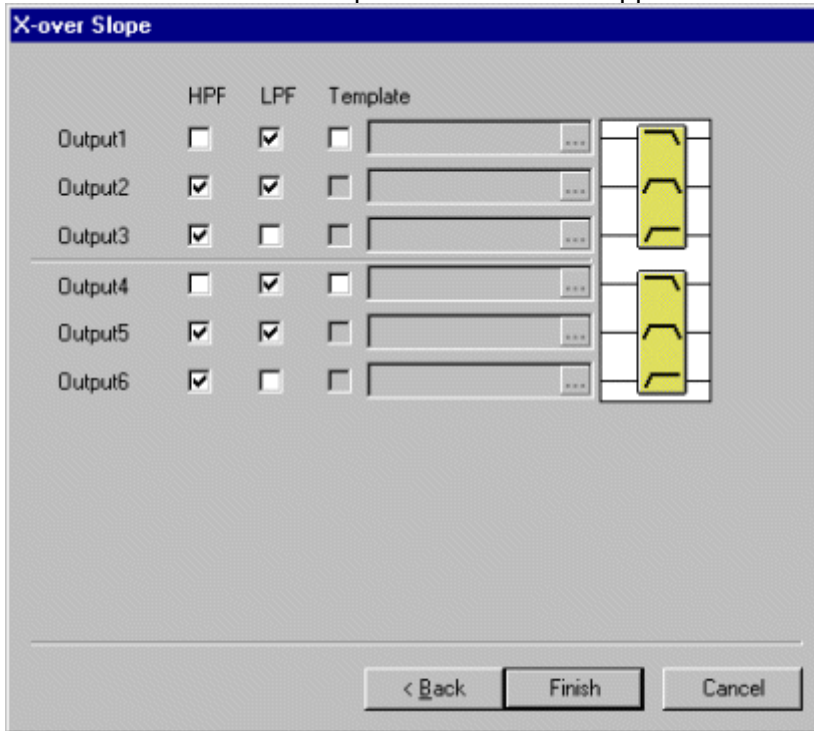

7. Make the X-over slope settings by clicking the appropriate check boxes. The settings status for each output is displayed in the right-hand portion of the window.
8. When using an existing template file, click the check box for the corresponding channel's "Template". You can directly input a filename, or you can make a selection from the dialog box, which can be displayed by clicking the ... part.

- Check the correctness of your settings and click “Finish”. The Signal Flow area will appear, as shown in the figure below.

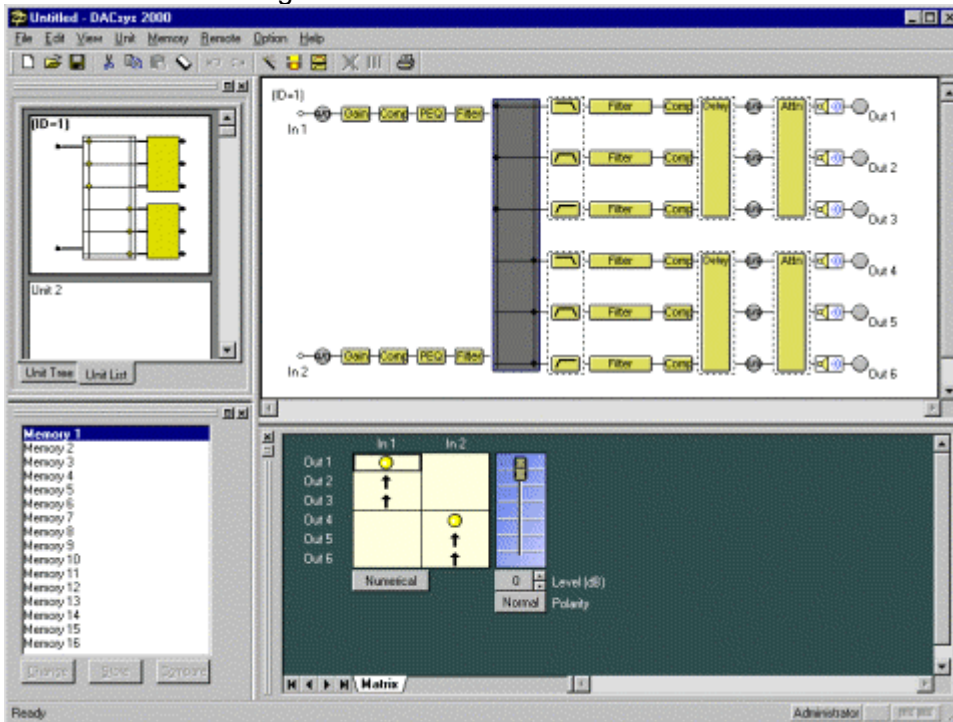

Deleting a unit

Select the unit you wish to delete in the Unit Viewer or Flow Viewer. From the menu bar, select Unit →Delete... to display a confirmation dialog box. Click “OK” to delete the selected unit.

Changing the number of inputs and outputs of the unit

You can change the number of inputs and outputs of an already created unit. Select the unit whose input/output number you want to change in the Unit Viewer or Flow Viewer.

From the menu bar, select Unit →Change Unit Configuration... to display the Unit Configuration window.

Then make the settings just as you would when creating a unit.

Changing the Crossover Combination

You can change the crossover combination of an already created unit.

Select the unit whose crossover combination you want to change in the Unit Viewer or from the Flow Viewer.

From the menu bar, select Unit →Change X-over →Combination... to display the Crossover Combination window. Then make the settings as in the creation procedure.

Changing the Crossover Slope

You can change the crossover slope of an already created unit. Select the unit whose crossover slope you want to change in the Unit Viewer or Flow Viewer.

From the menu bar, select Unit →Change X-over →Slope... to display the Crossover Slope window. Then make the settings as in the creation procedure.

Changing the name of the unit

Select the unit whose name you want to change in the Unit Viewer or Flow Viewer.

From the menu bar, select Unit →Names... to display the Change Name dialog box.

Saving a unit as a template

Select the unit you want to save as a template in the Unit Viewer or Flow Viewer.

From the menu bar, select Unit →Save as a Unit Template → Unit Template... to display the Save File dialog box.

Saving the Crossover settings as a template

Select the Crossover box you want to save as a template in the Flow Viewer.

From the menu bar, select Unit →Save as a Unit Template →X-over Template... to display the Save File dialog box.

7. Unit Viewer

This section explains about the Unit Viewer.

The units are displayed in one column. It is possible to display up to 30 units.

There are two display modes. You can switch between them by clicking the tab at the bottom.

List display

It is possible to reduce size of the signal-processing image of the units and display up to 30 units. The unit name, the number of inputs and outputs, the matrix settings, and the crossover combination information will be displayed abbreviated. By clicking an already created unit, you can scroll through a linked Flow Viewer.

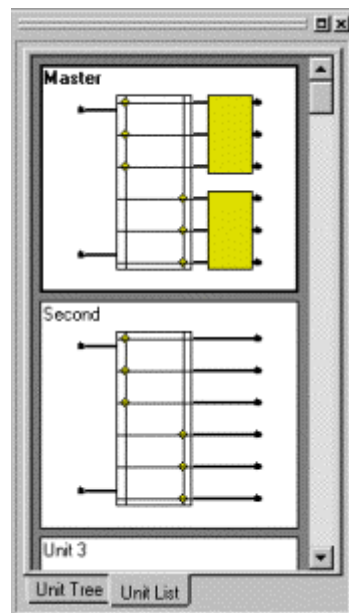

In the list display, the unit can be copied onto an empty unit by the created unit drag & drop.

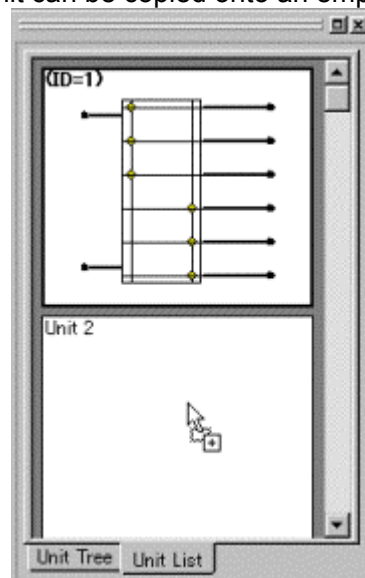

Tree display

You can display up to 30 units in a comparatively small display area. The unit names will be displayed in a tree format. By clicking an already created unit, you can scroll through a linked Flow Viewer.

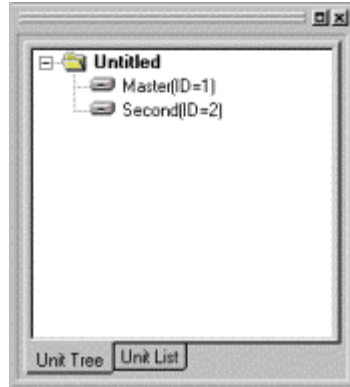

8. Memory Viewer

This section explains about the Memory Viewer.

The name and numbers of selected memory cells are displayed. By recalling a memory cell you can make additions to that cell or compare the content of memory cells.



- The memory cell number selected in the Memory list box is highlighted in bold letters.
- To recall a memory cell, click the desired memory cell number then click "Change".
- To write to a memory cell, click the number of the memory cell in which you wish to store the information then click "Store".
- To perform memory comparison, click the number of the memory cell to compare and click "Compare". The display will then be switched temporarily to the selected preset memory number. To compare the content of a memory with that before edit, click the number of the memory cell highlighted in bold letters and click "Compare". The previous status will be restored when you once again click "Compare".
- The Memory area can be switched between docked and floating indications.

9. Flow Viewer

This section explains about the Flow Viewer.

In the Flow Viewer a box is displayed to indicate the signal-processing functions of the unit and a graphical representation of the unit's signal-processing flow, showing each signal flow as a straight line connecting input and output.

The figure below is one example of the unit with a 2-input/6-output configuration.

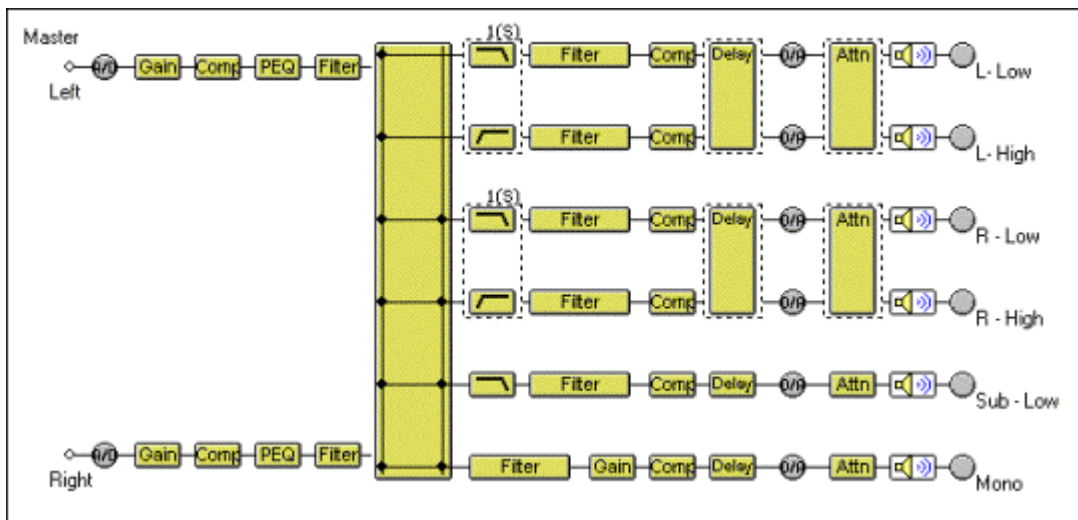



The signal-processing functions of each box are presented below.

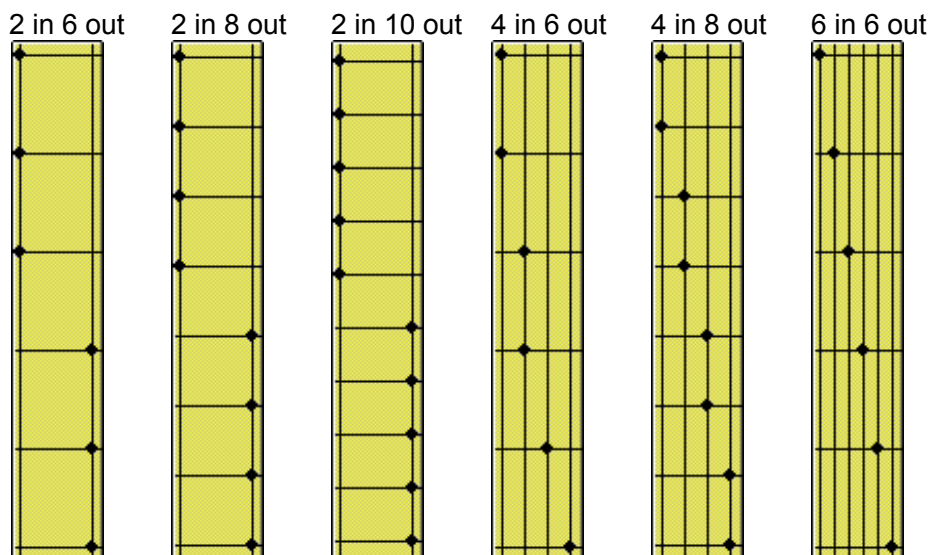







Matrix





Crossover (Xover)



-  ← Low-Pass Filter
-  ← High-Pass Filter
-  ← Band-Pass Filter(Low-Pass Filter + High-Pass Filter)

Other boxes



-  ← Gain
-  ← Compressor/Noise gate
-  ← Parametric equalizer
-  ← Graphic equalizer
-  ← Filters
-  ← Delay
-  ← Attenuator
-  ← Mute (off)
-  ← Mute (on)

Mute settings

To mute a channel, double-click the output's  box. A "X"(cross) will appear in the box, and that channel will be muted.  →  To cancel muting, double-click again on the same box.

 → .

Signal indicator

-  ← Displays the signal level immediately after A/D conversion.
-  ← Displays the signal level immediately after D/A conversion.
-  ← Displays the output level.

Red : The signal level is above 18 dB*

Green : The signal level is above -48 dB* but under 18 dB*

Gray : The signal level is under -48 dB*

* 0dB = 0.775V

10. Contents Viewer

This section explains about each Contents Viewer.

To display the Contents Viewer, click the desired box of the Flow Viewer.

Matrix

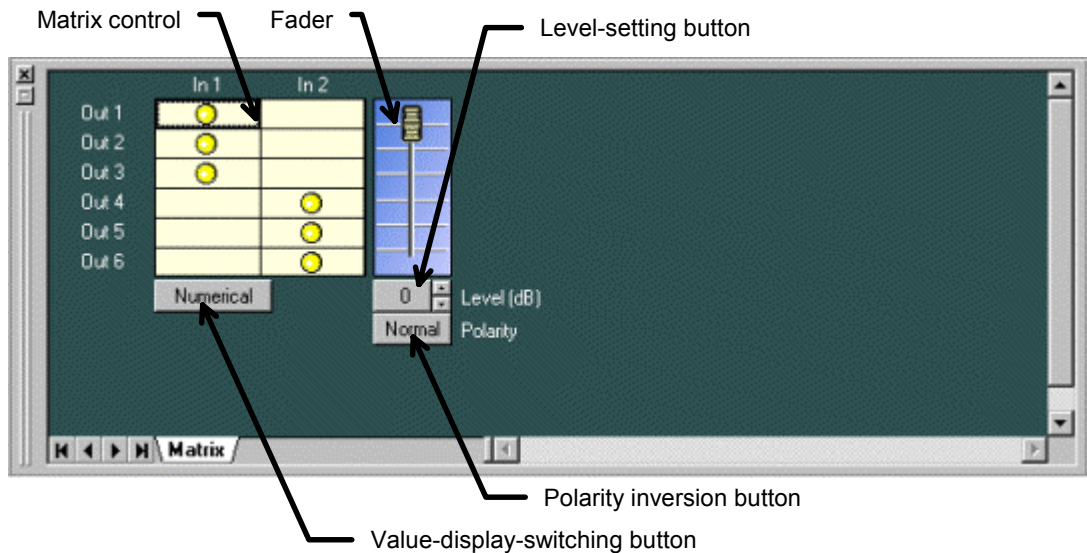

- The  symbols in the matrix-control boxes indicate the input/output routing.
- Double-clicking a matrix-control box toggles the display between on/off.
- The bold line framing a matrix-control box indicates the selected matrix point.
- By moving the fader switch up or down, you can change the level of the selected matrix point.
- The level for the selected matrix point is indicated as a numerical value on the level-setting button. Clicking this button enables you to directly input a numerical value. The spin button on the right allows you to increase or decrease the level in increments of 1 dB.
- The polarity-inversion button displays the polarity status of the selected matrix point. Click this button to invert the polarity.
- Click the value-display-switching button to display the level setting of each matrix point.

	In 1	In 2
Out 1	0 dB	0 dB
Out 2	0 dB	0 dB
Out 3	0 dB	0 dB
Out 4	0 dB	0 dB
Out 5	0 dB	0 dB
Out 6	0 dB	0 dB

Numerical

Gain

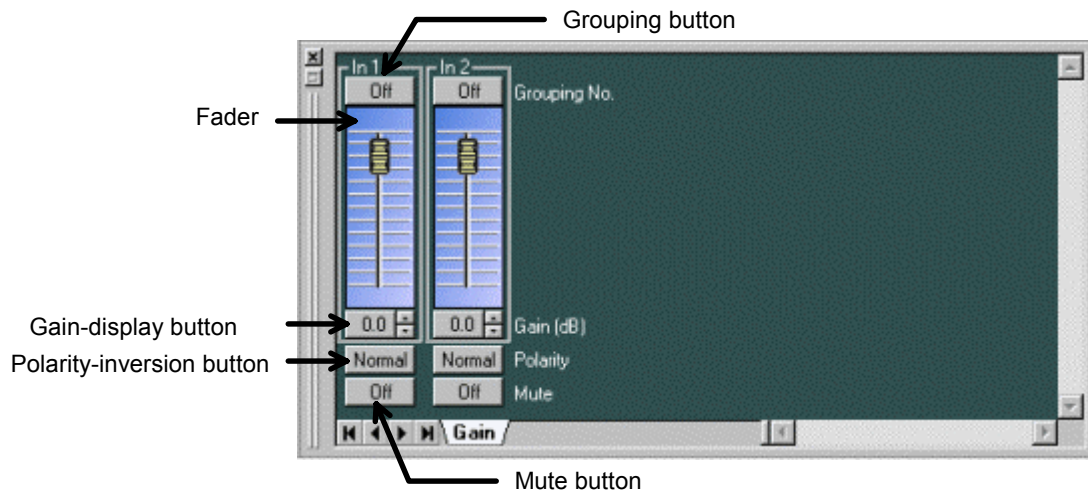

- By moving the fader switches up or down, you can change the level for each channel.
- The grouping number set for each channel is displayed on the grouping button. Clicking this button enables you to set the grouping for each channel. When moving the fader switch up or down for grouped channels, the switch of each fader belonging to the same group moves in the same way.
- The level for each channel is indicated as a numerical value on the level-display button. Clicking the button enables you to directly input a numerical value. Using the spin button on the right, you can move the numerical values up or down in increments of 0.5 dB.
- The Polarity-inversion button displays the polarity setting for each channel. By clicking this button you can invert the polarity.
- The Mute button displays the on/off status of the mute function for each channel. By clicking this button you can switch this function on/off.

Comp/Gate

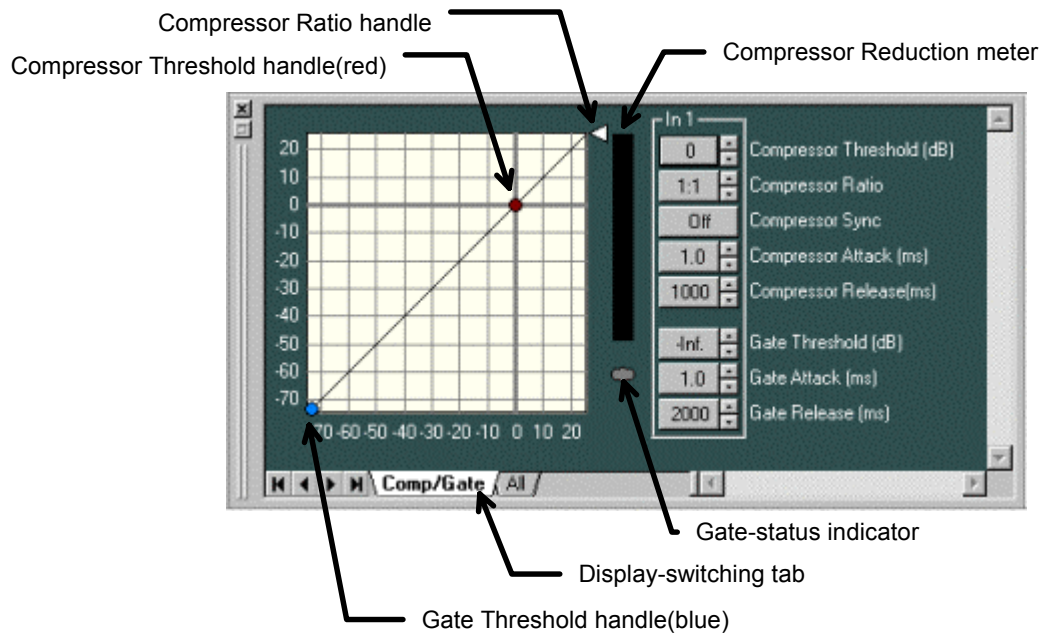

- By dragging the Compressor Threshold handle diagonally, you can change the compressor threshold level.
 - By dragging the Compressor Ratio handle up or down, you can change the compressor ratio.
 - By dragging the Gate Threshold handle diagonally, you can change the noise-gate threshold level.
 - The effectiveness of the compressor is displayed with a yellow graph bar on the Compressor Reduction meter.
- While the Noise Gate is working, the Gate-status indicator lights blue.
- If you click the All tab, the setting window for all the channels of the unit is displayed.

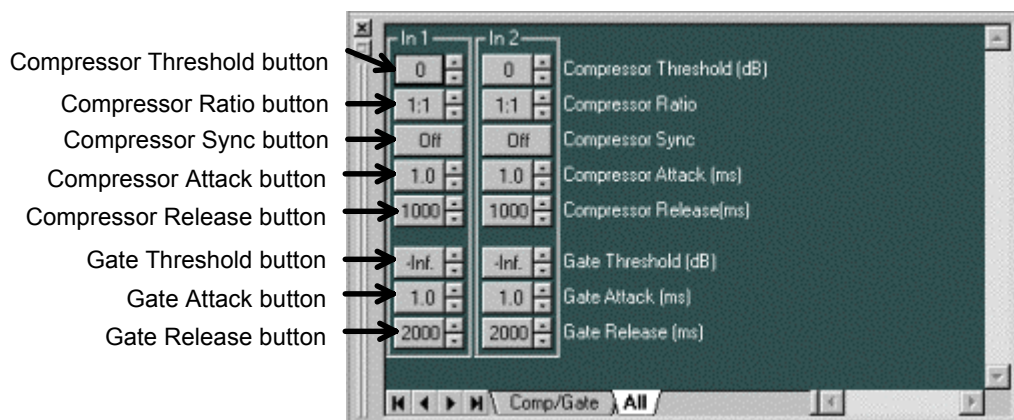

- The compressor threshold level for each channel is indicated as a numerical value on the Compressor Threshold button. Clicking the button enables you to directly input a numerical value. Using the spin button on the right, you can move the numerical values up or down in increments of 1 dB.

- The compressor ratio for each channel is indicated as a numerical value on the Compressor Ratio button. Clicking the button enables you to make a selection from the dropdown menu. You can also make changes by clicking the spin button on the right.
- The compressor sync for each channel is indicated as a numerical value on the Compressor Sync button. Clicking the button enables you to make a selection from the dropdown menu.
- The compressor attack time for each channel is indicated as a numerical value on the Compressor Attack button. Clicking the button enables you to make a selection from the dropdown menu. You can also make changes by clicking the spin button on the right.
- The compressor release time for each channel is indicated as a numerical value on the Compressor Release button. Clicking the button enables you to make a selection from the dropdown menu. You can also make changes by clicking the spin button on the right.
- The gate threshold level for each channel is indicated as a numerical value on the Gate Threshold button. Clicking the button enables you to directly input a numerical value. Using the spin button on the right, you can move the numerical values up or down in increments of 1 dB.
- The gate attack time for each channel is indicated as a numerical value on the Gate Attack button. Clicking the button enables you to make a selection from the dropdown menu. You can also make changes by clicking the spin button on the right.
- The gate release time for each channel is indicated as a numerical value on the Gate Release button. Clicking the button enables you to make a selection from the dropdown menu. You can also make changes by clicking the spin button on the right.

PEQ

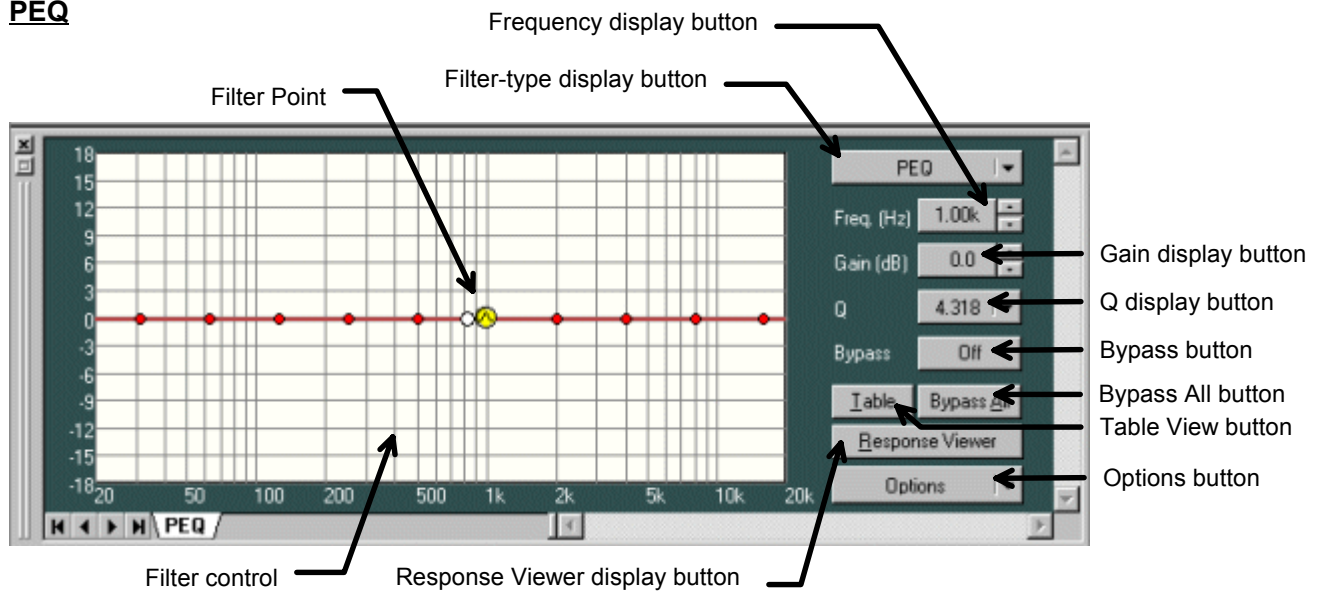

- The points that can be filtered are indicated with a circular symbol in the Filter control.
- The yellow circles indicate the selected filter points.
 - - PEQ
 - - HPF
 - - LPF
- By dragging a filter point up, down, left, or right, you can change the frequency and the gain of the selected filter point.
- When there is a white circle to the right of the filter point, by dragging it up or down, you can change the Q value of the filter point.
- The filter-type display button displays the filter type of the selected filter point. Clicking the button enables you to make a selection from the dropdown menu.
- The frequency of the selected filter point is indicated as a numerical value on the frequency display button. Clicking the button enables you to directly input a numerical value. Using the spin button on the right, you can move the numerical values up or down in increments of 1/24 octave (It is possible to change to a minimum unit).
- The gain of the selected filter point is indicated as a numerical value on the gain display button. Clicking the button enables you to directly input a numerical value. Using the spin button on the right, you can move the numerical values up or down in increments of 0.5 dB (It is possible to change to 0.1 dB).
- The Q button displays the Q value type of the selected filter point. Clicking the button enables you to make a selection from the dropdown menu.
- The Bypass button displays the on/off bypass status of the selected filter point. Clicking the button enables you to switch between on and off status.
- The Bypass All button displays the on/off bypass status of all the filter points in the filter control.

Clicking the button enables you to switch between on and off status.

- When the Table View button is pushed, Filter Control is displayed by the table form.
- Response Viewer display button shows or hides the Response Viewer(p. 38).
- The Options button changes the scale of the response graph, switches the Q display method, and sets the high resolution (frequency and gain).

GEQ

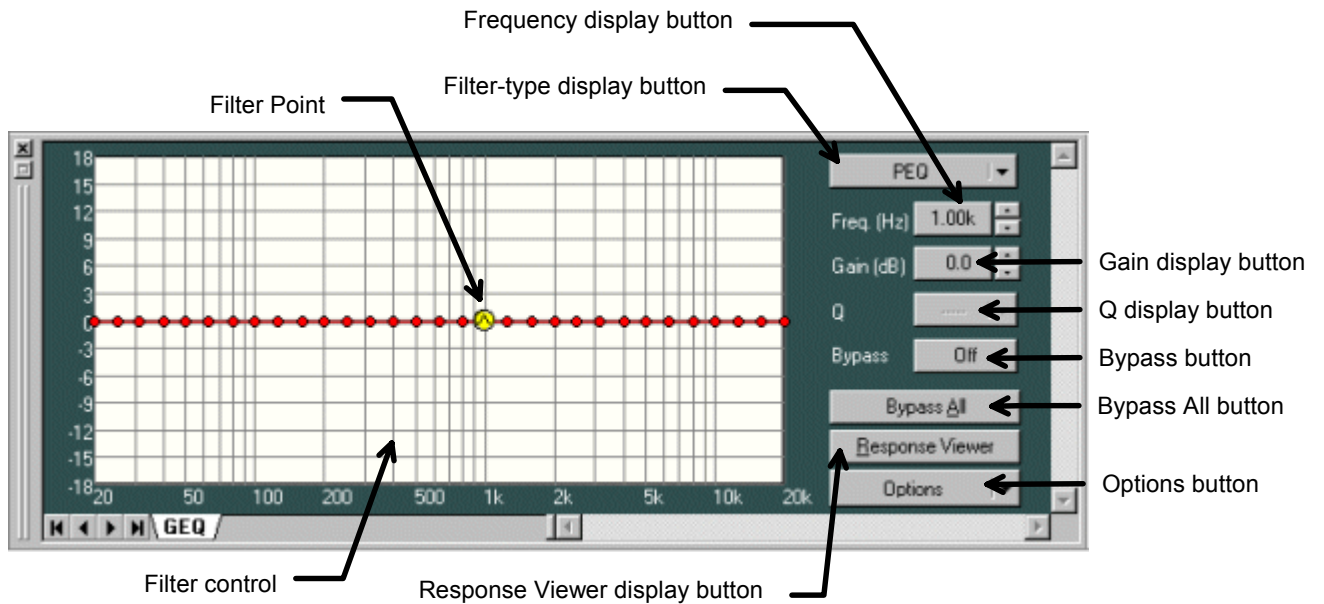

- The points that can be filtered are indicated with a circular symbol in the Filter control.

- The yellow circles indicate the selected filter points.

● - PEQ

● - HPF

● - LPF

- By dragging a filter point up, down, left, or right, you can change the frequency and the gain of the selected filter point.

- When there is a white circle to the right of the filter point, by dragging it up or down, you can change the Q value of the filter point.

- The filter-type display button displays the filter type of the selected filter point. Clicking the button enables you to make a selection from the dropdown menu.

- The frequency of the selected filter point is indicated as a numerical value on the frequency display button.

- The gain of the selected filter point is indicated as a numerical value on the gain display button. Clicking the button enables you to directly input a numerical value. Using the spin button on the right, you can move the numerical values up or down in increments of 0.5 dB (It is possible to change to 0.1dB).

- The Q button displays the Q value type of the selected filter point. Clicking the button enables you to make a selection from the dropdown menu.

- The Bypass button displays the on/off bypass status of the selected filter point. Clicking the button enables you to switch between on and off status.

- The Bypass All button displays the on/off bypass status of all the filter points in the filter control. Clicking the button enables you to switch between on and off status.

- Response Viewer display button shows or hides the Response Viewer(p. 38).
- The Options button changes the scale of the response graph, switches the Q display method, and sets the high resolution (frequency and gain).

Filter

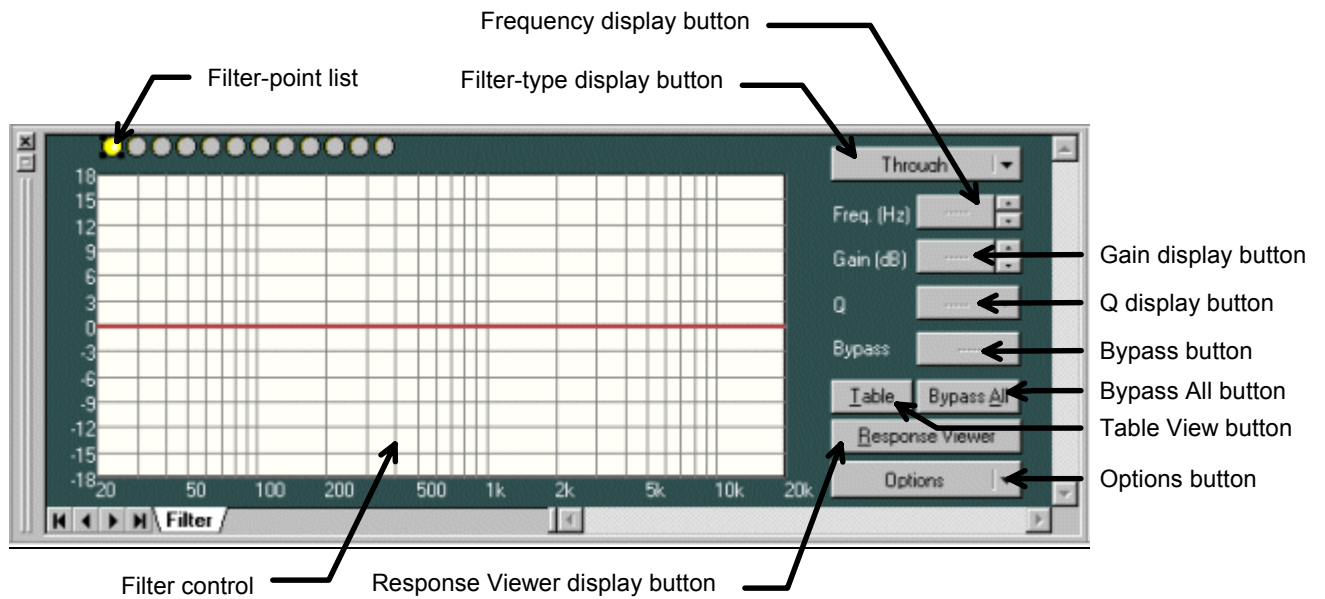

- The filter point is selected as necessary from the filter-point list. You can display the pop-up menu below by clicking the right button of the mouse at the desired point from the filter-point list.



- Any selection made from this list other than through will be displayed on the Filter control with a circle.

- The yellow circles indicate the selected filter points.

- ⦿ - PEQ
- ⦿ - HPF
- ⦿ - LPF
- ⦿ - High Shelving
- ⦿ - Low Shelving
- ⦿ - All Pass
- ⦿ - Notch

- Horn EQ

- By dragging a filter point up, down, left, or right, you can change the frequency and the gain of the selected filter point.
- When there is a white circle to the right of the filter point, by dragging it up or down, you can change the Q value of the filter point.
- The filter-type display button displays the filter type of the selected filter point. Clicking the button enables you to make a selection from the dropdown menu.
- The frequency of the selected filter point is indicated as a numerical value on the frequency display button. Clicking the button enables you to directly input a numerical value. Using the spin button on the right, you can move the numerical values up or down in increments of 1/24 octave (It is possible to change to a minimum unit).
- The gain of the selected filter point is indicated as a numerical value on the gain display button. Clicking the button enables you to directly input a numerical value. Using the spin button on the right, you can move the numerical values up or down in increments of 0.5 dB (It is possible to change to 0.1dB).
- The Q button displays the Q value type of the selected filter point. Clicking the button enables you to make a selection from the dropdown menu.
- The Bypass button displays the on/off bypass status of the selected filter point. Clicking the button enables you to switch between on and off status.
- The Bypass All button displays the on/off bypass status of all the filter points in the filter control. Clicking the button enables you to switch between on and off status.
- When The Table View button is pushed, Filter Control is displayed by the table form.
- Response Viewer display button shows or hides the Response Viewer (p. 38).
- The Options button changes the scale of the response graph, switches the Q display method, and sets the high resolution (frequency and gain).

Xover

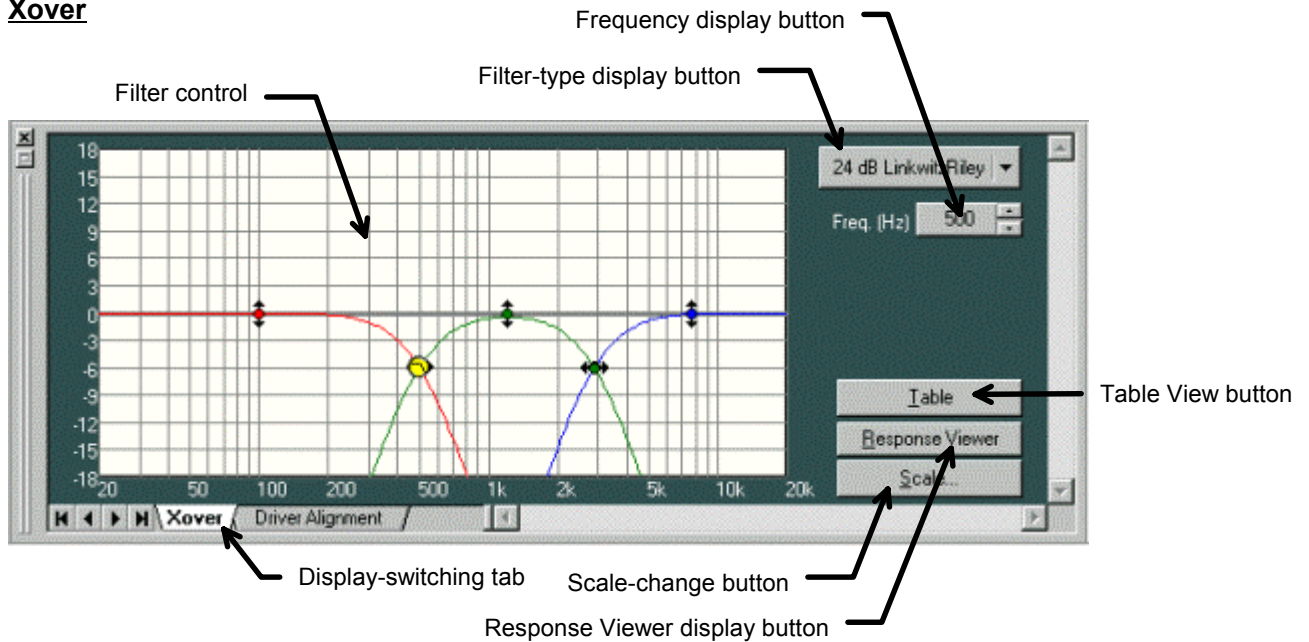

- The points that can be filtered are indicated with a circular symbol in the Filter control.
- The yellow circles indicate the selected filter points.
- (during selection), ◀▶ (when the selection is off): High-Pass Filter
- (during selection), ◀▶ (when the selection is off): Low-Pass Filter
- (during selection), ⬆ (when the selection is off): Gain Control
- By dragging the High-Pass or Low-Pass Filter point left or right, you can change the cut-off frequency of the selected filter point.
- By dragging the Gain Control point up or down, you can change the gain of the selected filter point.
- When a white circle is displayed to the left or right of the filter point, by dragging the white circle up or down you can change the Q value of the selected filter point.
- The display to the right of the Filter Control changes according to the filter type selected.

1. When "12 dB Variable-Q" or "18 dB Variable-Q" is selected

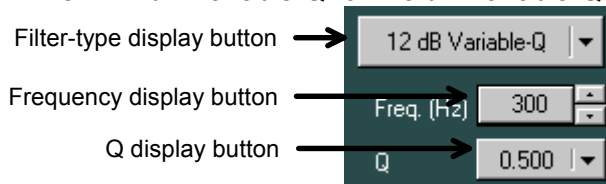

2. When "24 dB Variable-Q" is selected

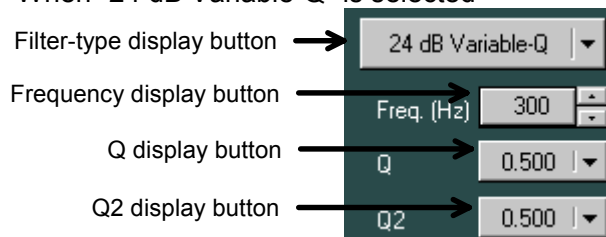

3. When a filter type other than the settings on the previous page is selected

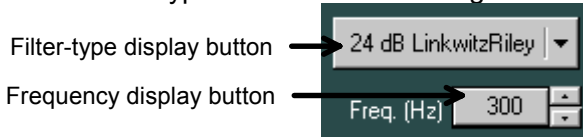

4. When Gain is selected

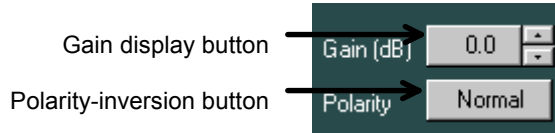

- The Filter-type display button displays the filter type of the selected filter point. Clicking the button enables you to make a selection from the dropdown menu.
- The frequency of the selected filter point is indicated as a numerical value on the Frequency display button. Clicking the button enables you to directly input a numerical value. Using the spin button on the right, you can move the numerical values up or down in increments of minimum unit.
- The Q and Q2 display buttons display the Q values of the selected filter point. Clicking the button enables you to make a selection from the dropdown menu.
- The gain of the selected filter point is indicated as a numerical value on the gain display button. Clicking the button enables you to directly input a numerical value. Using the spin button on the right, you can move the numerical values up or down in increments of 0.5 dB.
- The Polarity-inversion button displays the polarity status of the selected filter point. Click this button to invert the polarity.
- The Response Viewer display button allows you to switch the response-area display on/off.
- The scale-change button allows you to change the graph scale of the Filter control.
- When The Table View button is pushed, Filter Control is displayed by the table form.
- Clicking **Driver Alignment** of the display-switching tabs displays the setting window for time correction with the Xover box.

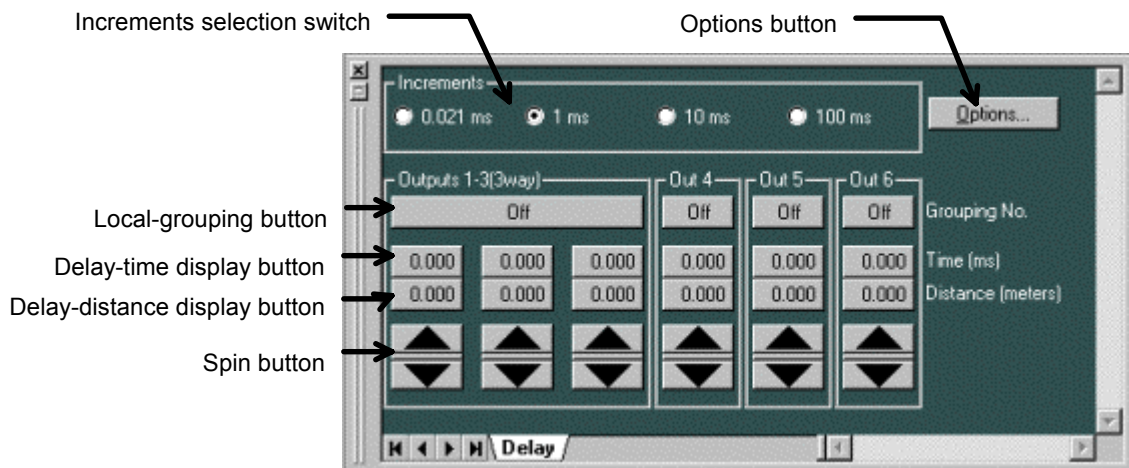

- The local grouping number set for each channel is displayed on the Local Grouping button. Clicking the button enables you to perform the local-grouping settings for each channel.
- The delay time for each channel is indicated as a numerical value on the Delay-time display button. Clicking the button enables you to directly input the desired numerical value.
- The delay distance for each channel is indicated as a numerical value on the Delay-distance display button. Clicking the button enables you to directly input the desired numerical value.
- By using the spin button you can increase or decrease the delay time by the smallest increment.
- Using the Increments selection switch, you can select the smallest increment for the delay time, which can be used to make changes with the spin button.
- Clicking Options displays the dialog box below.

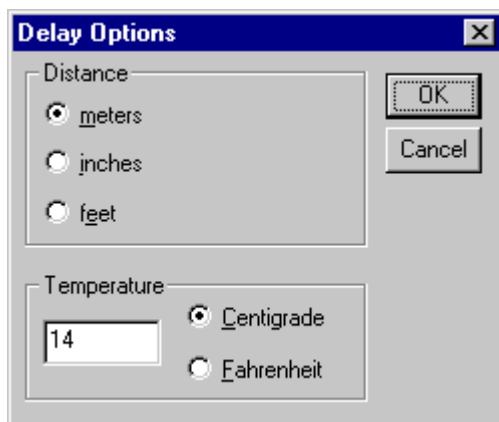

- You can select the distance-measuring unit displayed on the Delay-distance display button, from among meters, inches, and feet.
- You can set the temperature used in the distance calculation Displayed on the delay-distance display button.

Delay

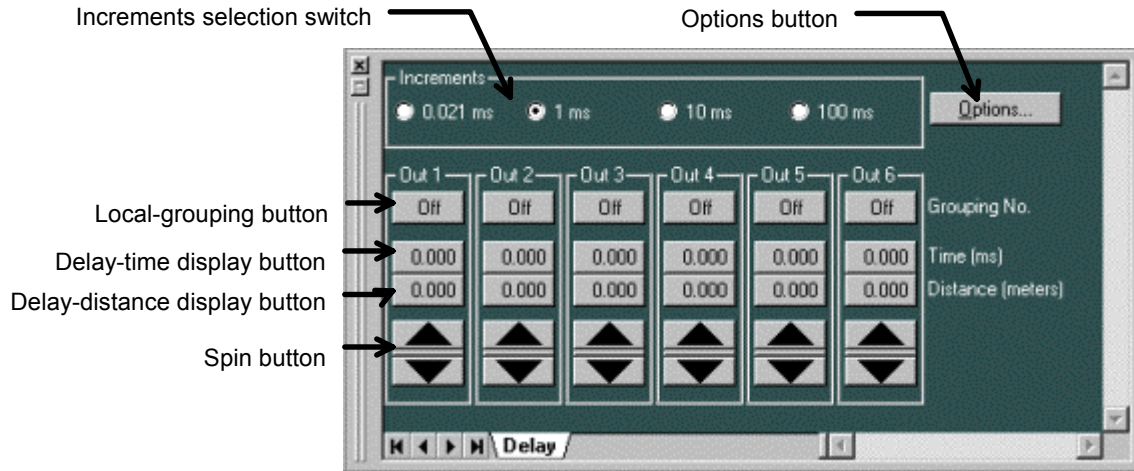

- The grouping number set for each channel is displayed on the grouping button. Clicking this button enables you to set the grouping for each channel.
- The delay time for each channel is indicated as a numerical value on the Delay-time display button. Clicking the button enables you to directly input the desired numerical value.
- The delay distance for each channel is indicated as a numerical value on the Delay-distance display button. Clicking the button enables you to directly input the desired numerical value.
- By using the spin button you can increase or decrease the delay time by the smallest increment.
- Using the Increments selection switch, you can select the smallest increment for the delay time, which can be used to make changes with the spin button.
- Clicking Options displays the dialog box below.

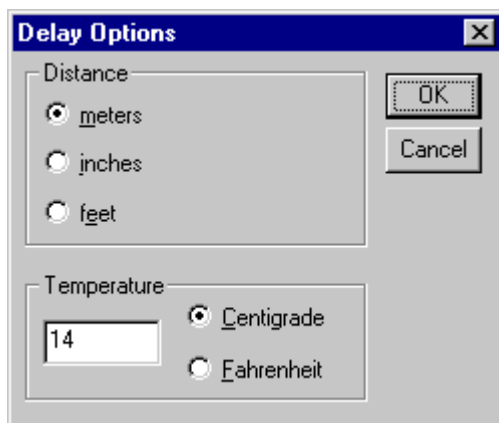

- You can select the distance-measuring unit displayed on the Delay-distance display button, from among meters, inches, and feet.
- You can set the temperature used in the distance calculation displayed on the Delay-distance display button.

Attn

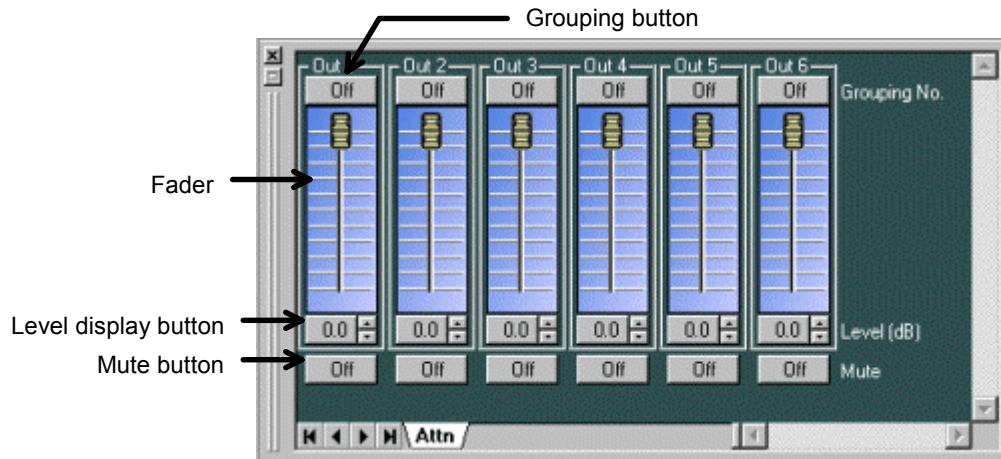

- The grouping number set for each channel is displayed on the Grouping button. Clicking this button enables you to set the grouping for each channel.
- By moving the Fader switches up or down, you can change the level for each channel.
- The level for each channel is indicated as a numerical value on the Level-display button for that channel. Clicking the button enables you to directly input a numerical value. Using the spin button on the right, you can move the numerical values up or down in increments of 0.5 dB.
- The Mute button displays the on/off status of the mute function for each channel. By clicking this button you can switch this function on/off.

11. Response Viewer

This section explains about the Response Viewer.

To show or hide the Response Viewer, select from the menu bar View → Response View or click **Response Viewer** in the PEQ/GEQ/Filter/Xover viewer.

The Response Viewer features the Output Response and the Xover Response.

1. Output Response

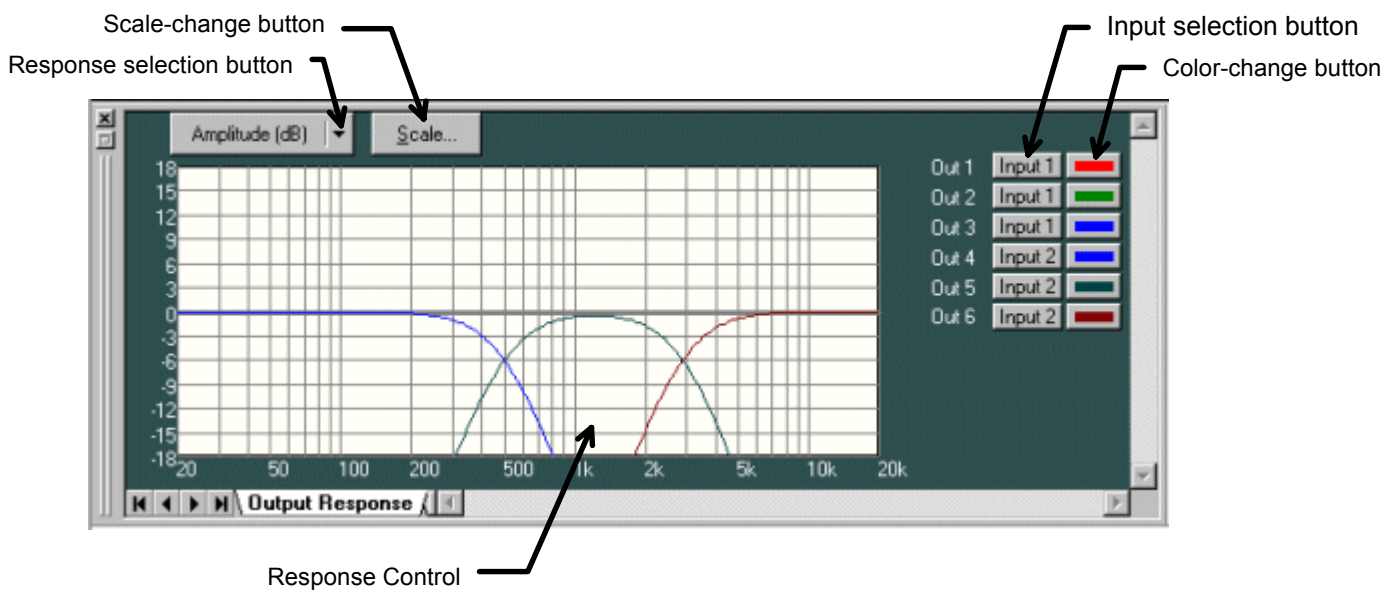

- You can display the total response from the input to the output.
- For each output channel, you can select the input to which the matrix sets the routing.
- You can display three types of response: amplitude, phase and group delay characteristics.
- The Response selection button displays the type of frequency characteristics being currently displayed. Clicking this button enables you to make a selection from the dropdown menu. Two display modes are available to show the characteristics: a single display of the amplitude, the phase, or the group delay, and a dual display of their characteristics combination.
- Using the Scale-change button, you can change the graph scale of the response controller.
- Using the Input selection button, you can turn on/off the response display for each output channel, and select input channels.
- Using the Color-change button, you can change the color of the response curves of each channel.

2.Xover Response

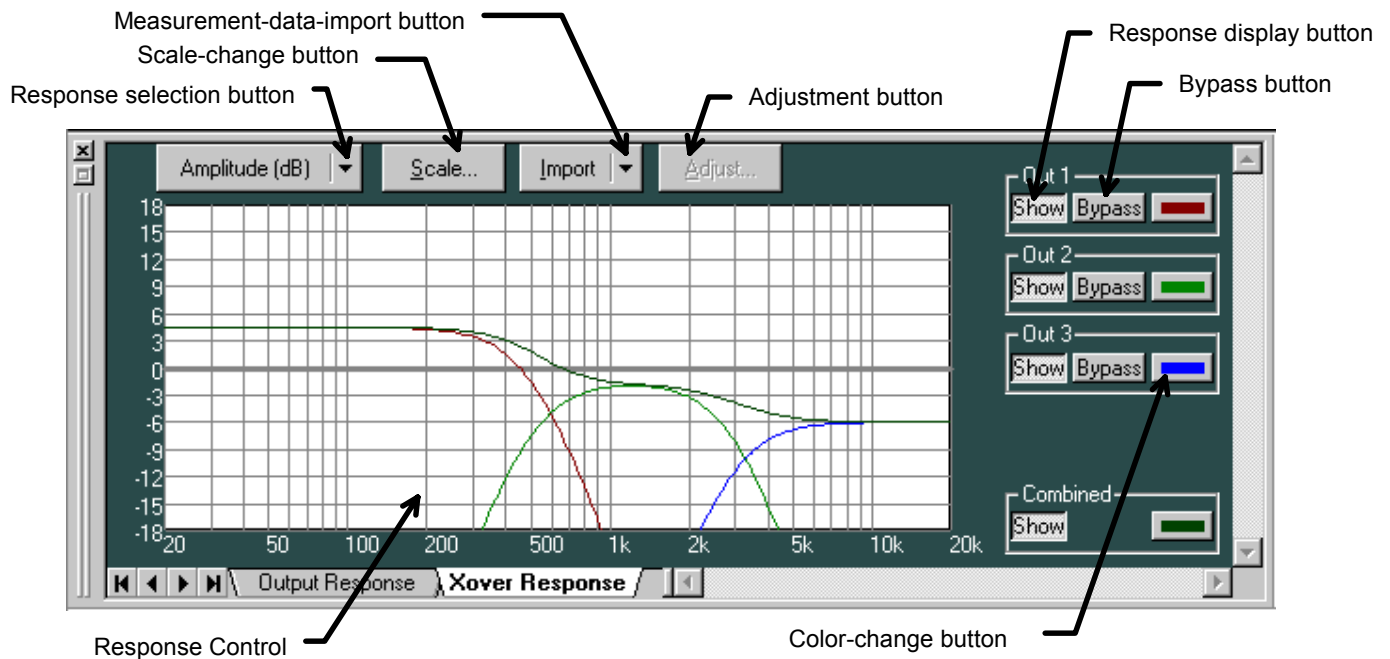

- You can display the response curves of the crossover response and the filter response following it.
- In addition to individual channel responses, you can also display the combined response as the result of adding them together.
- You can display three types of response: amplitude, phase and group delay characteristics.
- By importing measurement data you can conduct a simulation of a crossover setting for the multiple-way speakers.
- The Response selection button displays the type of frequency characteristic being currently displayed. Clicking this button enables you to make a selection from the dropdown menu. Two display modes are available to show the characteristics: a single display of the amplitude, the phase, or the group delay, and a dual display of their characteristics combination.
- Using the Scale-change button, you can change the graph scale of the response controller.
- To import measurement data, click the Measurement-data-import button, and then select the target channel from the dropdown menu.

- The dialog box below appears when you click the Adjustment button.

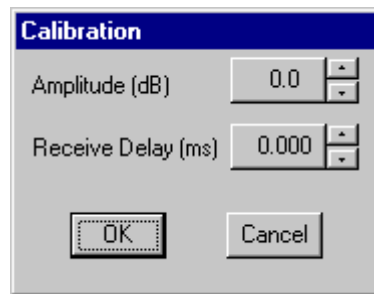

Change **Amplitude** when correcting the amplitude response, and **Receive Delay** when correcting the phase response.

- Using the Response display button, you can turn on/off the response display for each channel.
- Using the Bypass button, you can select whether or not to add individual channel responses to the combined response.
- Using the Color-change button, you can change the color of the response curves of each channel.

12. Preset Memory

There are 16 preset memory cells, which can be freely read from or written to.

Recalling preset memory

From the menu bar, select Memory → Change → Memory (1-16).

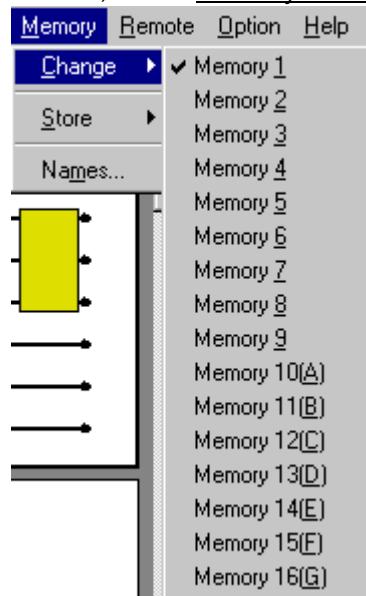

Saving to preset memory

From the menu bar, select Memory → Store → Memory (1-16).

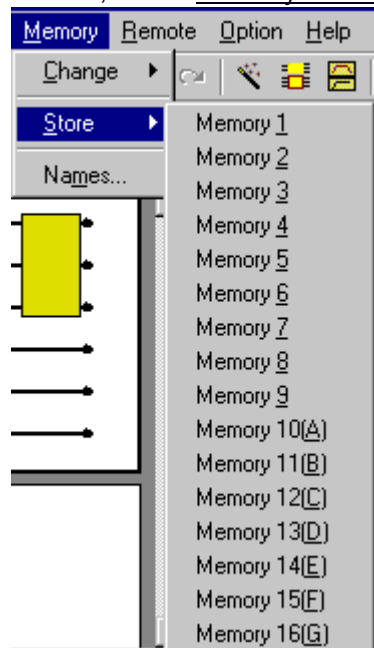

Change name

From the menu bar, select Memory → Change name...

13. Level Monitor Viewer

This section explains about the Level Monitor Viewer.

The Level Monitor Viewer is a window where the I/O level of the unit can be monitored when PC is connecting the unit and the communication.

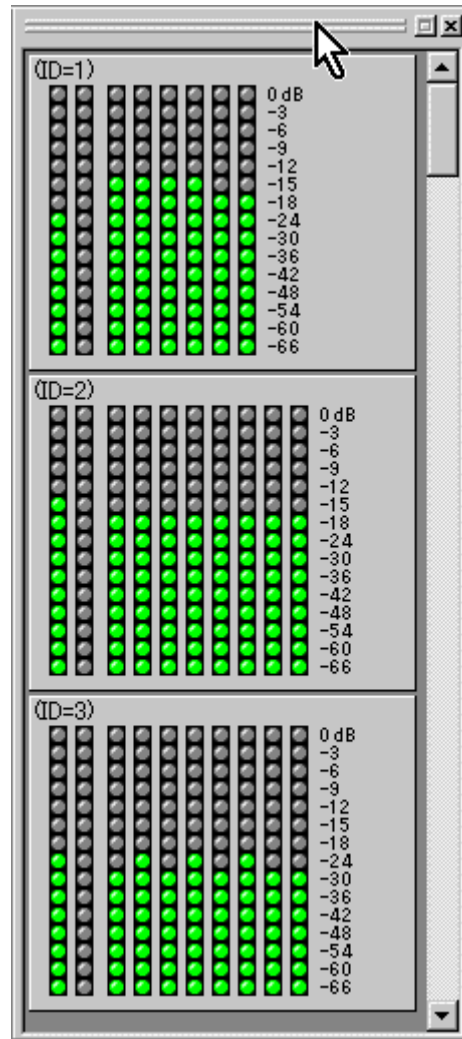

14. Mute All Window

This section explains about the Mute All Window.

The Mute All Window enables you to mute the output of all units while communication between the PC and units is being made.

You can switch the display between docking and floating for the Window.

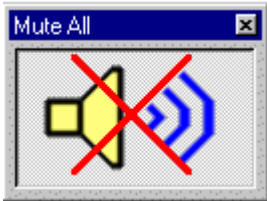

Mute ON: Mutes the output of all units.



Mute OFF: Depends on the mute settings for each output channel (p. 22).

15. Communications

This software automatically sets the communication port and the data-transfer speed. The transfer speed is automatically adjusted to the setting status of the connected DP-0206 unit.

- To initiate communications with the PC, select Remote → Connect from the menu.
- While the window below is displayed, the system is searching for a possible connection.



- If the memory information for the PC and in the unit is different, the dialog box below will appear.

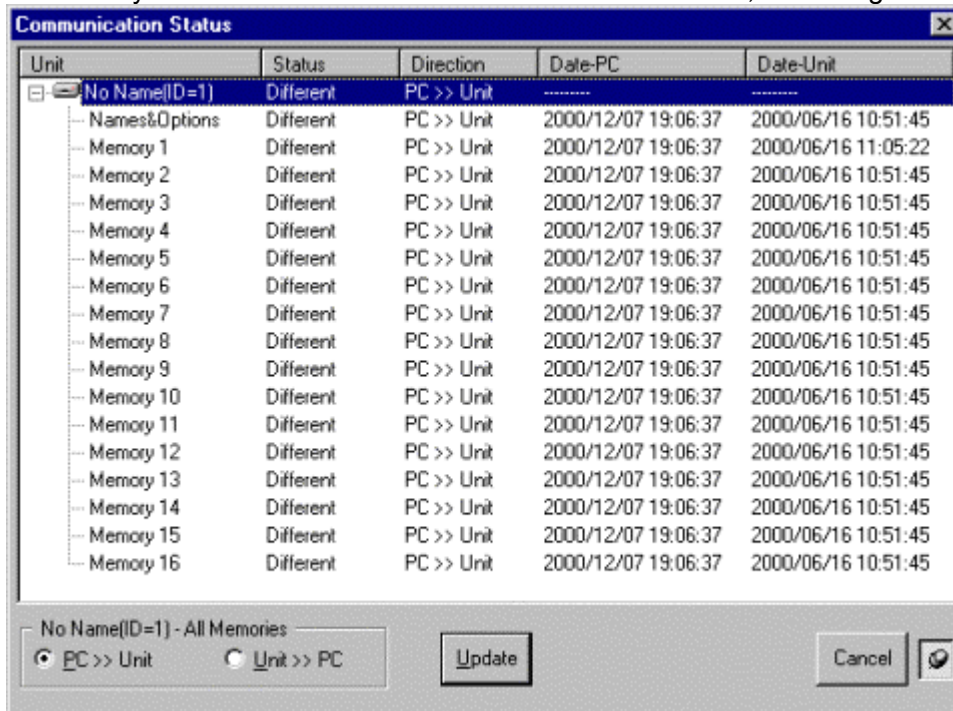

- When transferring data from a PC to the unit, set the transfer direction to **PC >> Unit**. When transferring data from the unit to a PC, set the transfer direction to **Unit >> PC**. You can also set a different data transfer direction for each memory cell.

- Check to be sure that your selections are correct, then click “Update”. Data transfer will begin.

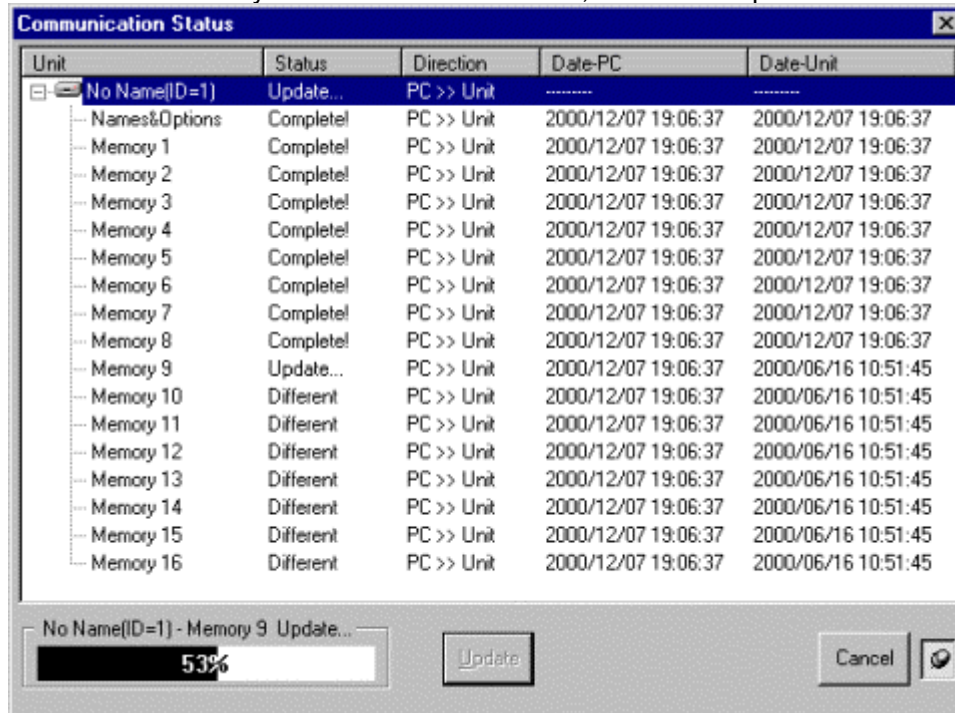

- After data transfer completion, click “Complete”.

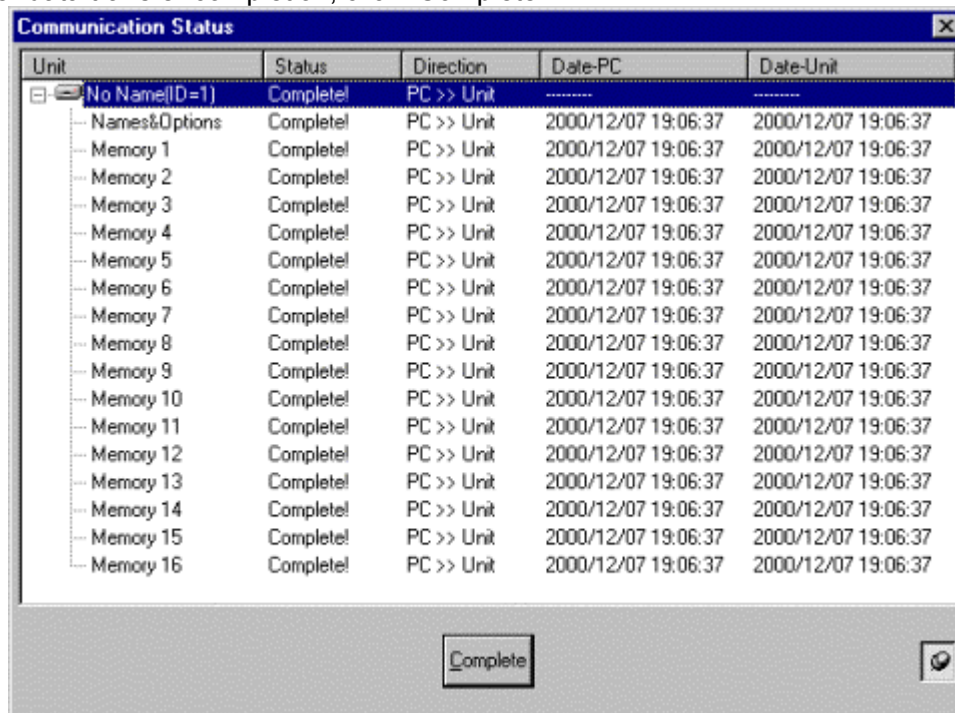

- To terminate the communication connection, select Remote →Disconnect.
- To transmit the data of PC to the unit side compulsorily, select Remote →Bulk transmission from the menu.
- To receive all the data of the unit side to PC, select Remote →Bulk receiving from the menu.

16. User Level

This software can use the user level properly, when the prohibition is set of the explanation from now on. A discussion of the user level follows. There are two kinds of user levels as follows.

- Administrator

When the user level setting is not enabled, the user level automatically is administrator.

And the user level is a administrator when logging it on as a manager on the logon screen.

- Operator

The user level is an operator when not logging it on as a automatically on the logon screen.

Select from the menu bar Option → Security Settings when enabling the user level. The dialog box below appears.



When click the checkbox The user level is enabled, the Password for Administrator is displayed. Enter the password character string of 16 characters or less to the Password and the Confirm Password, and push the “OK” button.



When the file will be opened next time, the following logon screens are displayed when the user level is enabled.

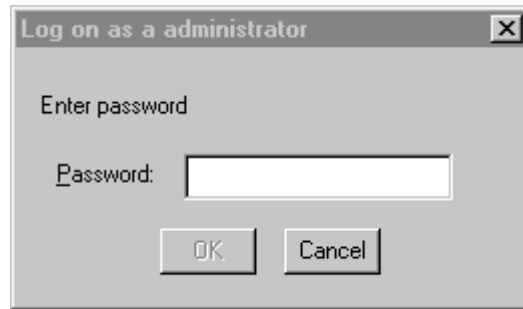

Please enter the password and push the "OK" button when logging it on as a administrator. When the logon screen is shut by other methods, the user level is operator.

A current user level is displayed at the right of the main screen lower status bar.



17. Prohibition Settings

This software can do the prohibition setting to various change operations. The operation which can be prohibited is as follows.

1. Creating, deletion, and I/O changes of unit
2. Change of crossover combinations
3. Change in grouping settings
4. Change of the name
5. Store to memories
6. Change of parameter of each box

To do the prohibition setting to 1-5, select from the menu bar Option → Security Settings. The dialog box below appears.



Four stages "Off", "Low", "Mid", and "High" can be set respectively.

Off	All changes are permitted.
Low	The operator is prohibited from changing. The change in the prohibition setting is possible.
Mid	The operator is prohibited from changing all.
High	Changes other than the prohibition setting by the administrator are prohibited.

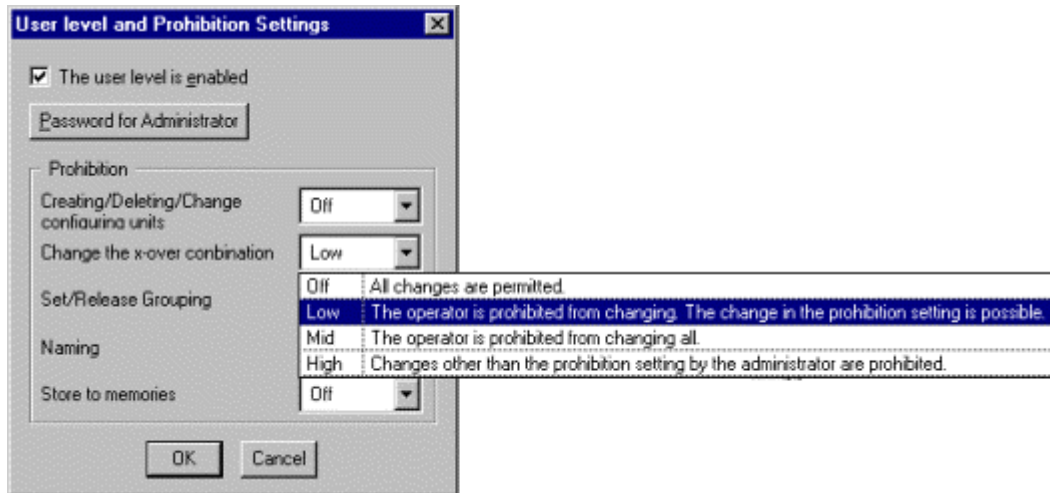

About the Store to memories, a separate prohibition setting can be done to the memory of 16.

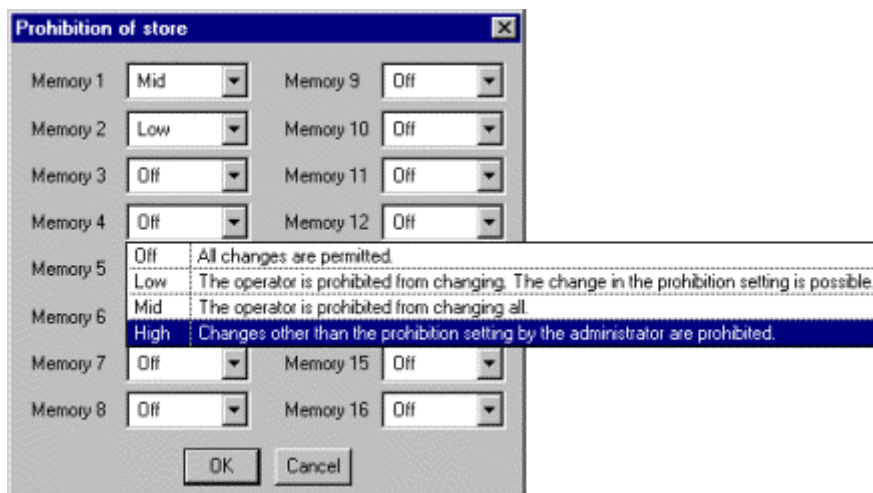
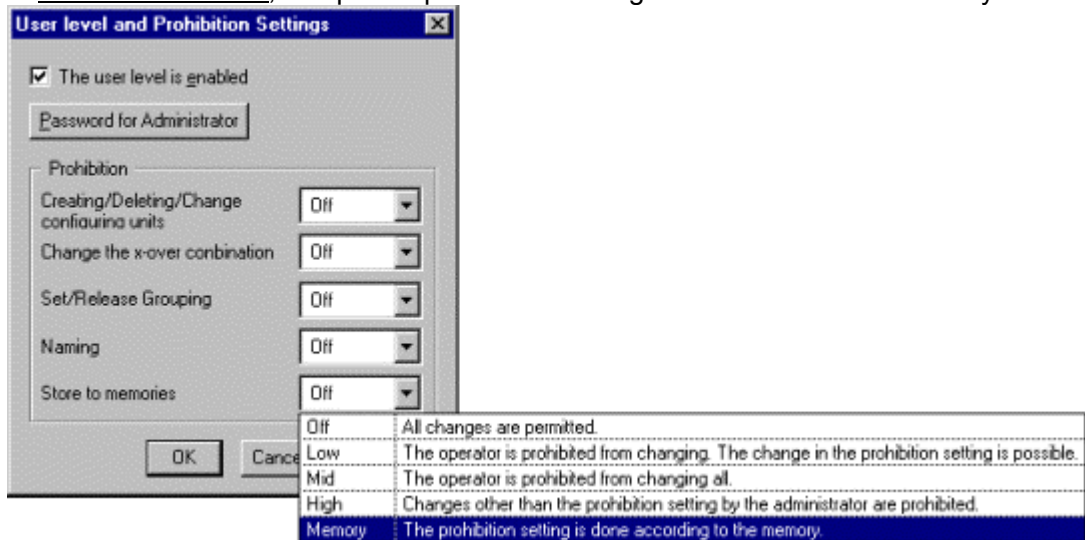

Select Edit → Write Protect to Box from the menu to do the prohibition setting of the change of the parameter of each box after selecting the box by the Flow Viewer.

18. Print

This software can print the data of the active document.

To print, select from the menu bar File → Print. The dialog box below appears.

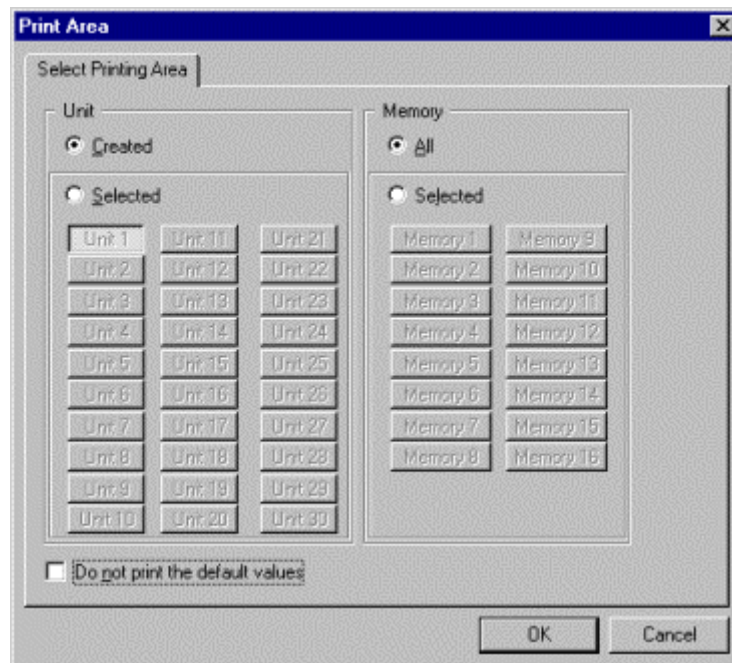

- To print the content of all created units, select the "Created" button in the "Unit". To print an arbitrary unit, after selecting "Selected" button in the "Unit", select the unit with 30 buttons.
- To print content all of the 16 memories, select the "All" button in the "Memory". To print an arbitrary memory, after selecting "Selected" button in the "Memory", select the memory with 16 buttons.
- So as not to print an initial value of PEQ/GEQ/Filter/Xover, click the "Do not print the default values" checkbox. As a result, the number of sheets and the print time of a form necessary for the print can be saved.

19. Export

This software can export the data of the active document as the Microsoft Excel data.

To export, select from the menu bar File → Export.

The dialog box below appears.

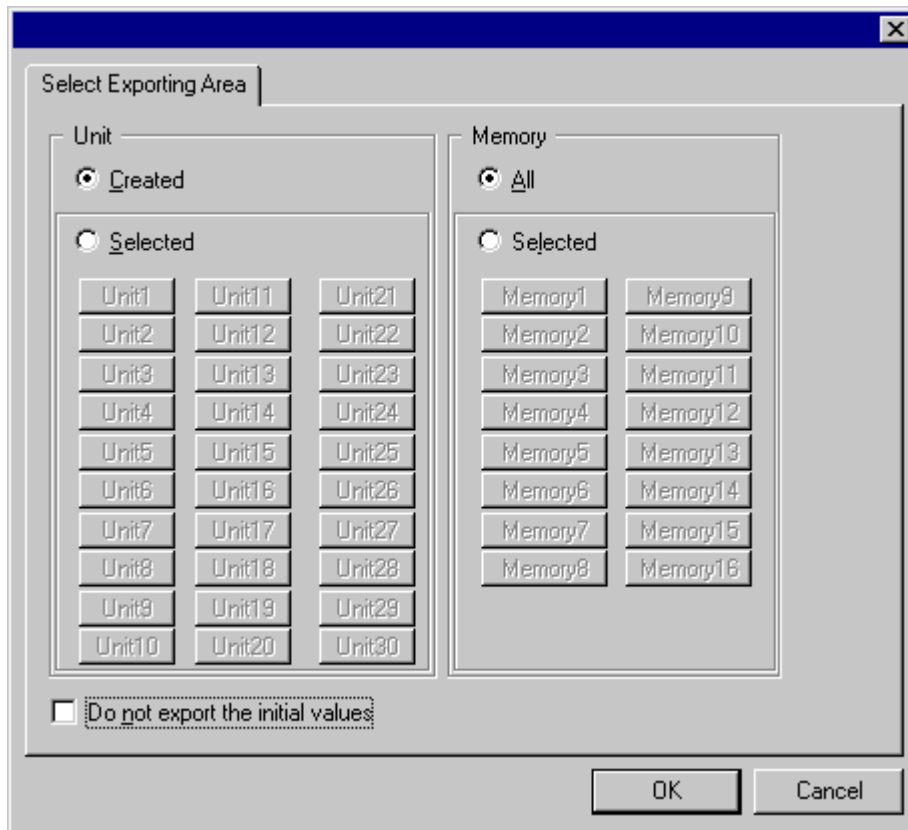

- To export the content of all created units, select the "Created" button in the "Unit". To export an arbitrary unit, after selecting "Selected" button in the "Unit", select the unit with 30 buttons.
- To export content of all of the 16 memories, select the "All" button in the "Memory". To export an arbitrary memory, after selecting "Selected" button in the "Memory", select the memory with 16 buttons.
- So as not to export an initial value of PEQ/GEQ/Filter/Xover, click the "Do not export the default values" checkbox. As a result, the export time can be saved.

Note

The menu regarding the export appears only when the Microsoft Excel is installed in the PC.

The effective version of the Excel is "Excel 95", "Excel 97" or "Excel 2000".

The Excel of any designated version allows you to export a data file in the Excel format.

20. DQ-C01 Settings

Here, an optional DQ-C01 Remote Control Module will be described.

1. Outline

Installing the DQ-C01 permits the DP-0206's memory selection, output volume adjustment, and output muting to be remotely controlled from external equipment. For its installation, refer to the instruction manual attached to the DP-0206 or the DQ-C01.

The DQ-C01 is initially set to the memory selection function, with terminals 1-8 set to memory numbers 1-8, respectively. You can recall memory numbers 1-8 by shorting terminals 1-8 with terminal C. Refer to the following explanations when changing the memory number to be recalled, or when setting the memory number for other function.

2. Setting Screen

Select from the menu bar Option → External Control, and the dialog below appears.

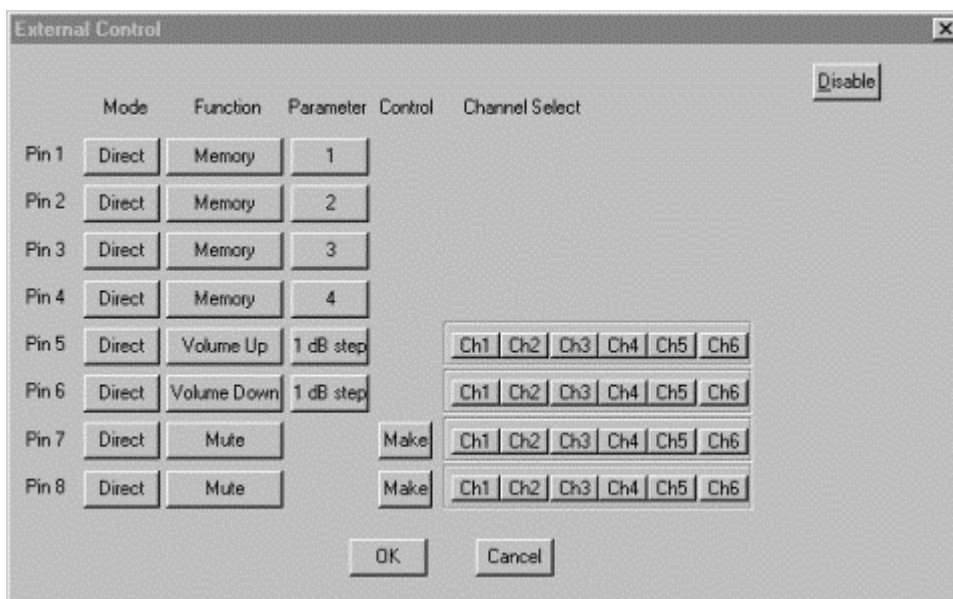

- Mode

Either Direct or Binary Mode is assigned to the DQ-C01. Terminals 1-3 can only be used for the Direct Mode.

Direct Mode

Controls terminals 1-8 and terminal C by shorting them.

Binary Mode

Provides any one of terminals 4-8 and terminal C with "short" or "open" mode to control

them. When selecting the Binary Mode, perform the setting in turn from terminal 8.

- Function

Sets terminal functions. It is initially set for Memory Selection.

Memory --- Memory Selection

Volume Up/Down --- Output Volume Adjustment

Mute --- Output Muting

None --- No function is set for the terminal.

- Parameter

Sets the memory number when selecting the memory, and the step when adjusting the volume.

- Control

Sets the control method to be assigned to the terminals. The control method when the function is set for "Mute" can be selected from "Make" or "Pulse".

Make

Shorting each terminal with terminal C enables "Mute", and opening them disables "Mute".

Pulse

The "Mute" function is enabled and disabled alternately whenever each terminal is shorted with terminal C.

- Channel selection

Selects the channel of the group for which the output volume is adjusted or output is muted. If optional output modules are used to expand the output, the expanded channels can also be selected for the group.

- Disable

Clicking the Disable button located on the upper right of the screen makes it impossible to perform control from the DQ-C01. Note that out of controls performed before the **Disable** button was pressed, memory numbers are maintained. However, both the output volume adjustment and output muting are cleared. To make their control possible again, click the **Enable** button.

Each Function Setting

1. Memory Selection

(A) Direct Mode Memory Selection

Select arbitrary memory numbers (1 - 16) and assign them to the terminals.

- (1) Set Mode for "Direct."
- (2) Set Function for "Memory."
- (3) Set memory numbers 1 - 16 at Parameter.

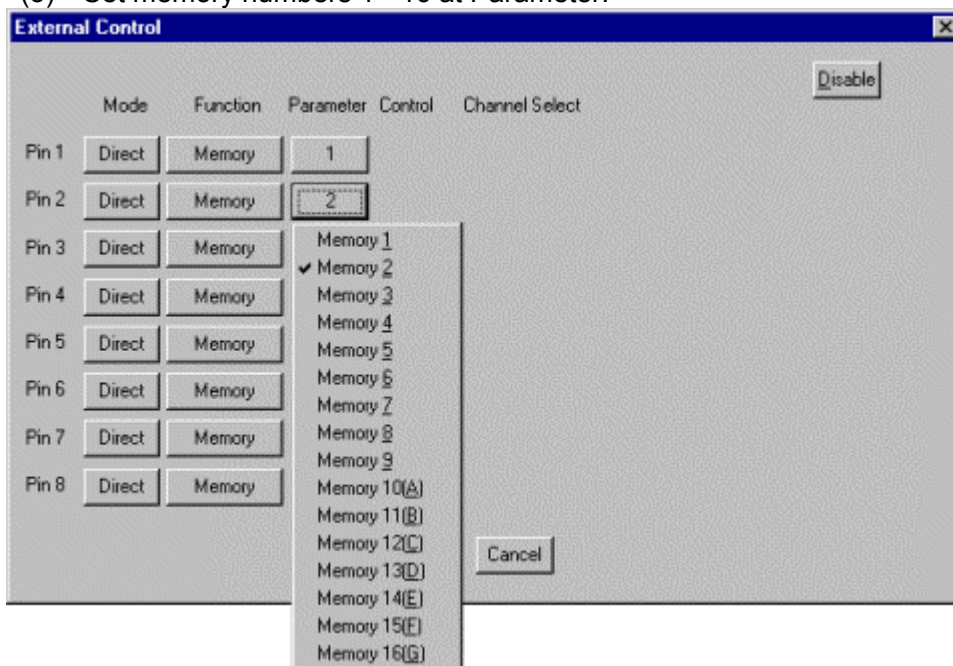

(B) Binary Mode Memory Selection

When selecting 9 or more memories with a single DQ-C01 unit but the number of function terminals is insufficient, you can increase the number of memories to be selected with the small number of terminals by selecting Binary Mode.

- (1) Depending on the number of memories to be used, set mode of necessary terminals to "Binary".

Number of memories to be used	Terminals to be set for Binary Mode
Memories 1 and 2	Terminal 8
Memories 1-4	Terminal 7 (and 8)
Memories 1-8	Terminal 6 (7 and 8)
Memories 1-16	Terminal 5 (6, 7 and 8)

- (2) Register the function into "Memory".

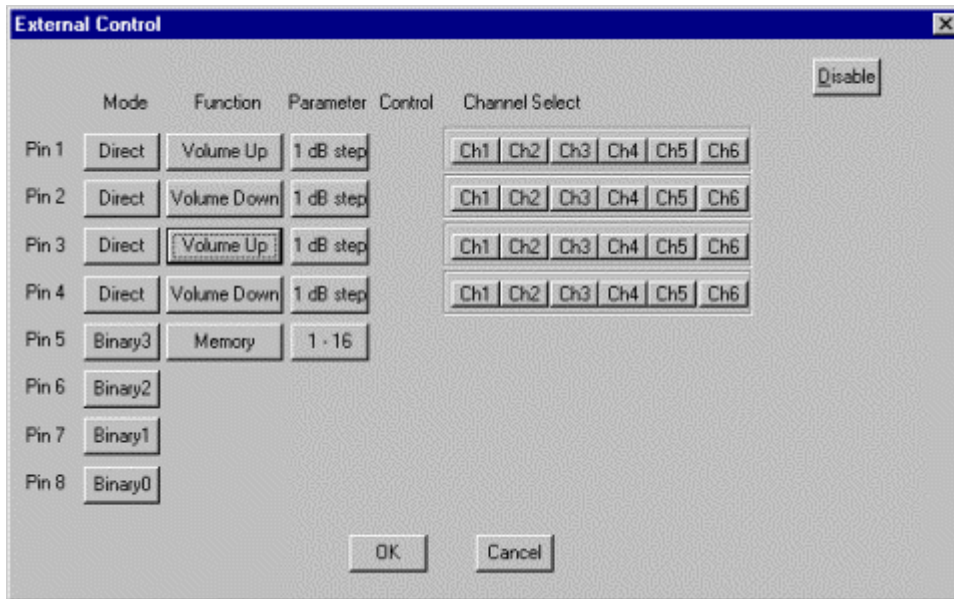

(Note)

- (1) When performing Memory Selection using Binary Mode, the terminals set for Direct Mode can only select volume adjustment or muting settings.
- (2) The memory number to be selected has been pre-determined depending on the status provided to terminals of Binary 3–0.

2. Output Volume Adjustment

Give an offset value for the output attenuator's set value.

(Note)

- (1) The volume adjustment is only possible for the units in which the DQ-C01 is installed.
- (2) Set output channels as a group and adjust the volume for individual groups.
- (3) For the channels included in a single group, the unit's output attenuator's value is not identical, but the offset value to be given is identical.
- (4) When the same channel is included in 2 different groups, the offset value to be given to that channel is the result of adding up the values of each group.
- (5) The adjustable range is the value that can be registered into the output attenuator (0 dB to $-\infty$ dB).
- (6) The given offset value is cleared if the power is switched off.

(A) Volume Adjustment in Direct Mode

Assign the group's Volume Up or Volume Down function to the terminal.

- (1) Set Mode for "Direct".
- (2) Set Function for Volume Up or Down.
- (3) Select the variation step from among 1 dB step, 3 dB step and 6 dB step.
- (4) Click the channel whose volume is adjusted at Channel Select.

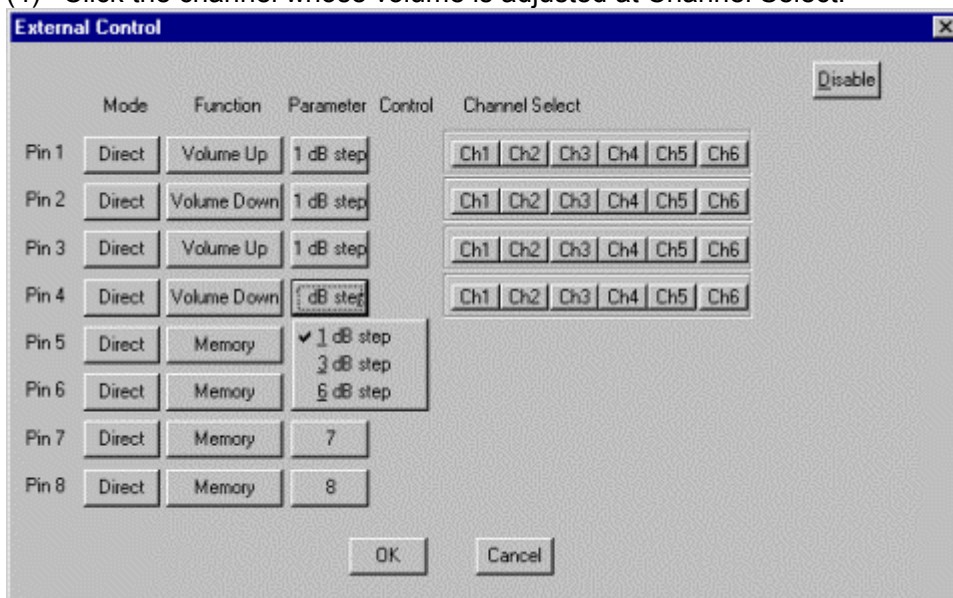

(B) Volume Adjustment in Binary Mode

When adjusting the volume of 5 groups or more using a single DQ-C01 unit, if the number of terminals is insufficient, by selecting Binary Mode, the number of volume adjustment groups can be increased with the small number of terminals.

- (1) Depending on the number of groups for which the volume is adjusted, set the necessary terminals to the Binary Mode.

Number of Groups	Terminals to be set to Binary Mode
Up/Down for up to 3 groups	Terminal 6 (7 and 8)
Up/Down for up to 7 groups	Terminal 5 (6, 7 and 8)
Up/Down for up to 10 groups	Terminal 4 (5, 6, 7 and 8)

- (2) Set Function for Volume.

- (3) Select the variation step from among 1 dB step, 3 dB step and 6 dB step.

- (4) Click the Group Setting button to channels for each group.

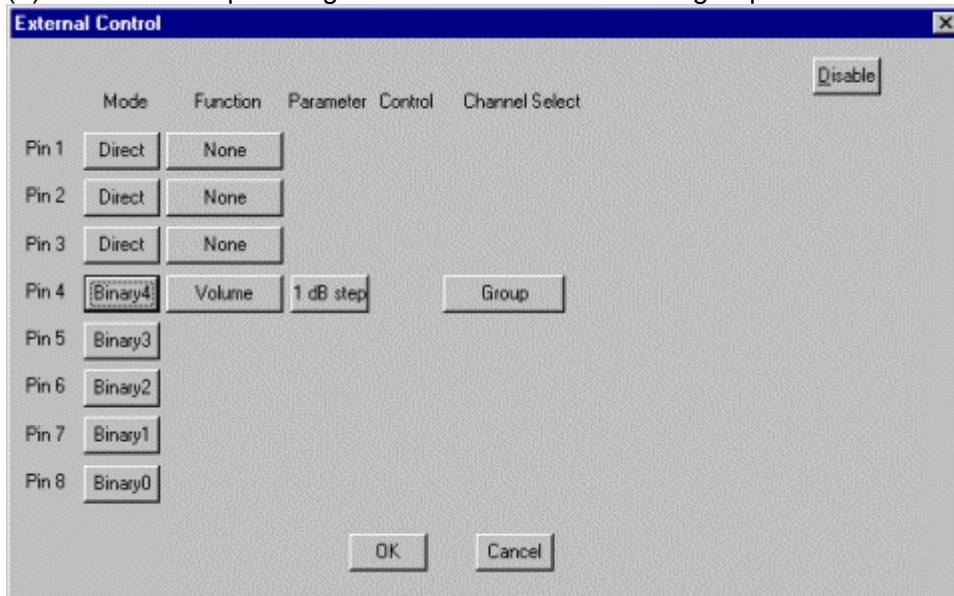

(Note)

- (1) The group number for which the volume is adjusted has been pre-determine depending on the status to be provided to terminals of Binary 4-0.
- (2) When carrying out the volume adjustment using the Binary Mode, the terminals set for Direct Mode can be only used for Memory Selection or Muting settings.

3. Output Muting

- (1) Set Mode for "Direct".
- (2) Set Function for "Mute".
- (3) Select the control method from Make and Pulse.
- (4) Click the channel you wish to mute at Channel Selection.

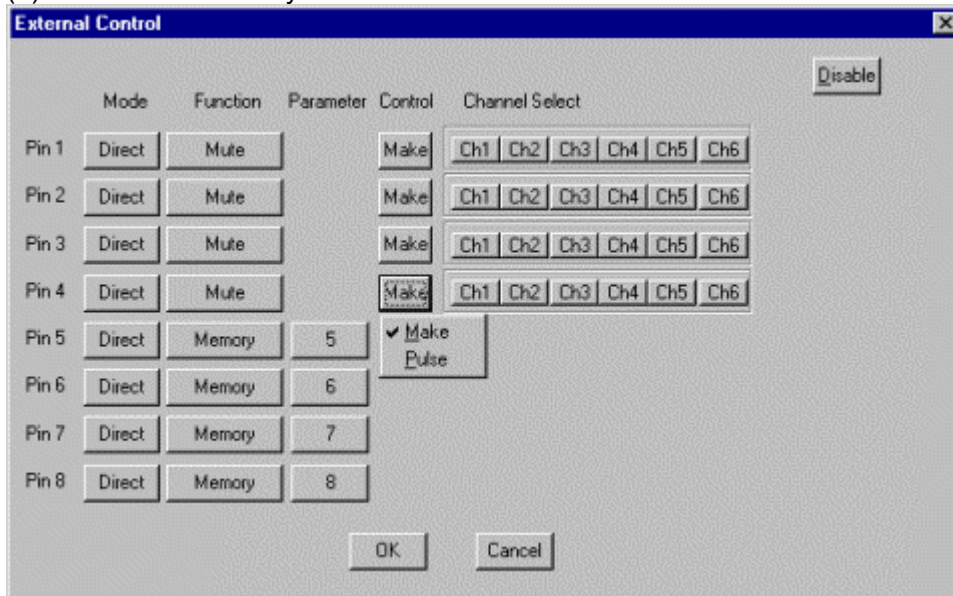

(Note)

- (1) Output Muting is only possible for the units in which the DQ-C01 is installed.
- (2) For the channels for which Muting has been enabled by means of setup software, Muting cannot be disabled at the DQ-C01.
- (3) Switching off the power cancels the muting carried out at the DQ-C01.

● Terminal Function Summary

The following table shows the functions that can be assigned to terminals 1-8.

	All in Direct Mode	Binary Mode Memory Selection	Binary Mode Volume Adjustment
Pin 1	Memory Selection / Volume Adjustment / Muting	Volume Adjustment / Muting	Memory Selection / Muting
Pin 2	Memory Selection / Volume Adjustment / Muting	Volume Adjustment / Muting	Memory Selection / Muting
Pin 3	Memory Selection / Volume Adjustment / Muting	Volume Adjustment / Muting	Memory Selection / Muting
Pin 4	Memory Selection / Volume Adjustment / Muting	Volume Adjustment / Muting	Volume Adjustment: Maximum 10 groups
Pin 5	Memory Selection / Volume Adjustment / Muting	Memory Selection: Maximum 16 memories	
Pin 6	Memory Selection / Volume Adjustment / Muting		
Pin 7	Memory Selection / Volume Adjustment / Muting		
Pin 8	Memory Selection / Volume Adjustment / Muting		
Pin C	COM		

(Note) Functions to be used by terminals in Binary Mode cannot be used by the remaining terminals in Direct Mode.

21. Supplement

- Docking/floating window operation

The Mute All Window and each viewer except Flow Viewer can be docked to the main window or floated on the desktop.

1. Example of the docked Memory Viewer

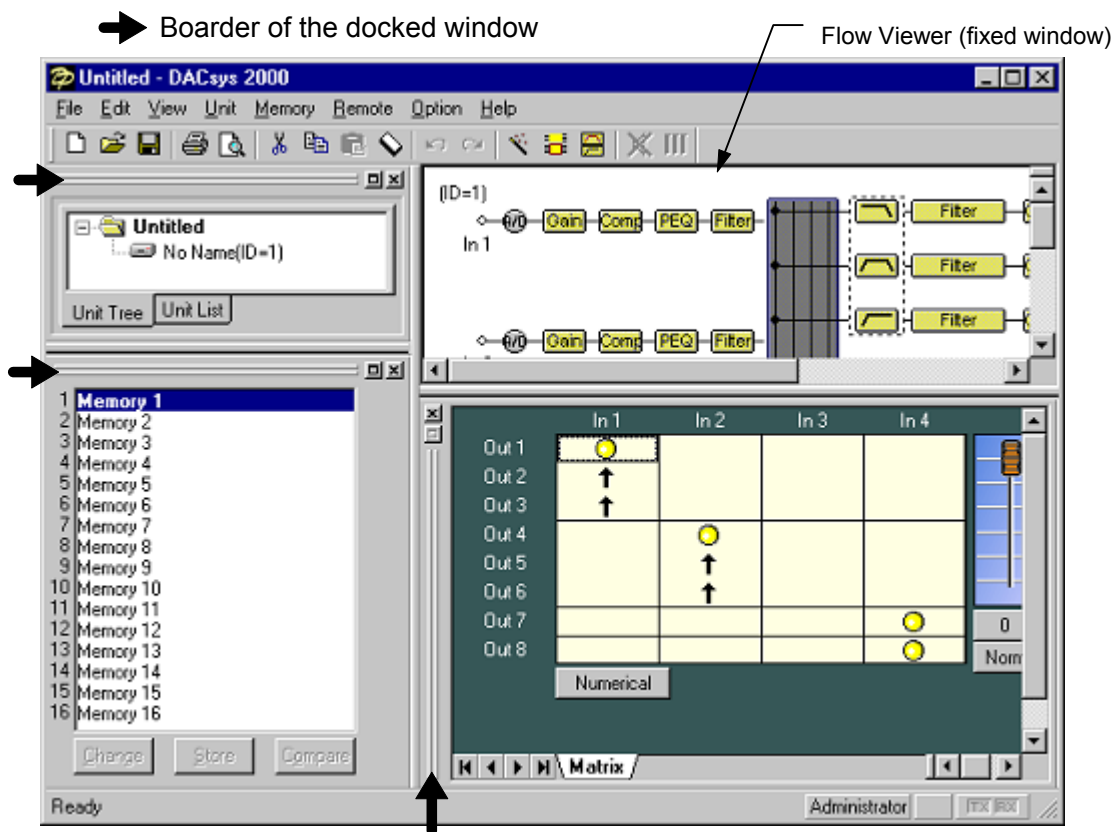

- Floating the window

To switch the window from docking to floating, double-click the boarder of the docked window.

2. Example of the floated Memory Viewer

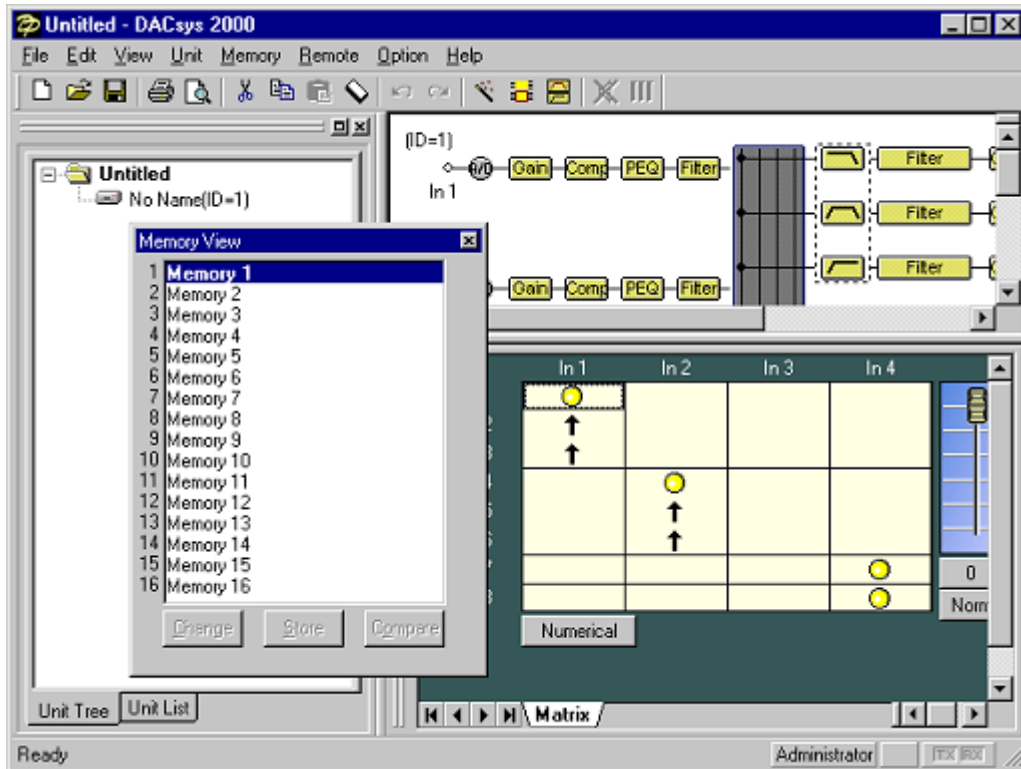

- Docking the window

To dock the floating window, double-click its title bar, or drag and drop its title bar to the desired position on the main window.

- Moving or resizing the floating window

To move the floating window, right click the title bar, then select "Move" from the dropdown menu, and drag and drop the title bar to the desired position.

(Note)

When you use drag & drop operation instead of using "Move" from the menu, you may dock the floating window depending on the position to which you drag and drop the window. To surely move the floating window, be sure to select "Move" from the menu.

To resize the window, click and drag the window's boarder.

22. Specifications

Software

OS	: Microsoft Windows 95/98/ME/2000, Windows NT ver. 4.0 compatible
Floppy Disk	: Two 3.5-inch 2HD disks
Number of Controllable Units	: Up to 30 DP-0206 units
Preset Memory	: 16 memories

Communications

Communication Method	: RS-232C
Communication Speed	: 115,200 bps, (38,400 bps, 19,200 bps, 9,600 bps)
Data Bit	: 8 bits
Stop Bit	: 1 bit
Parity	: None
Cable	: RS-232C straight cable

Equipment Setup Specifications (DP-0206)

Input and Output Configuration	: 2 in 6 out (I/O Expansion: 2 in 8 out, 2 in 10 out, 4 in 6 out, 4 in 8 out, 6 in 6 out)
--------------------------------	--

Signal Processing Box

Gain

Variable range : +12 dB to -60 dB, $-\infty$ dB, 0.5 dB steps, polarity Inversion
 Additional function : Muting function (input only)

Compressor/Noise gate (C/G)

Compressor Threshold : -16 dB* to +24 dB* 1 dB steps * 0 dB = 0.775V
 Compressor Ratio : 1 : 1, 2 : 1, 3 : 1, 4 : 1, 8 : 1, 12 : 1, 20 : 1, ∞ : 1
 Compressor Attack time: 0.02, 0.1, 0.2, 0.5, 0.7, 1.0, 1.5, 2, 3, 5, 7, 10, 20, 50, 70, 100 ms
 Compressor Release time: 10, 20, 50, 70, 100, 120, 150, 200, 250, 350, 700 ms
 1, 2, 3, 5 sec
 Compressor Sync : OFF, Group 1-5
 Gate Threshold : -72 dB* to -26 dB* 1 dB steps * 0 dB = 0.775V
 Gate Attack time : 0.1, 0.5, 1.0, 2, 5, 10, 50, 100 ms
 Gate Release time : 20, 70, 120, 200, 250, 350, 700, 2000, 5000 ms

Parametric Equalizer (PEQ)

No. of adjustment bands : 10 Bands

Filter Type	Center Frequency	Boost/Cut	Q
PEQ	20 Hz to 20 kHz 1/24 octave band or continuous variable type (effective figure: 3 digits)	\pm 12 dB 0.1 or 0.5 dB steps	0.267 - 69.249 (96points)

Filter Type	Cut-off Frequency	Q
HPF(6 dB) LPF(6 dB)	20 Hz to 20 kHz 1/24 octave band or	---
HPF(12 dB) LPF(12 dB)	continuous variable type (effective figure: 3 digits)	0.500 - 2.563 (51points)

Additional function : Band-bypass function, Bypass-all function
 Amplitude frequency characteristic graph indication

Graphic Equalizer (GEQ)

No. of adjustment bands : 10 Bands

Filter Type	Center Frequency	Boost/Cut	Q
PEQ	20 Hz to 20 kHz 1/3 octave band fixed (31 bands)	±12 dB 0.1 or 0.5 dB steps	0.267 - 69.249 (96points)

Filter Type	Cut-off Frequency	Q
HPF(6 dB) LPF(6 dB)	20 Hz to 20 kHz 1/24 octave band or	---
HPF(12 dB) LPF(12 dB)	continuous variable type (effective figure: 3 digits)	0.500 - 2.563 (51points)

Additional function : Band-bypass function, Bypass-all function
Amplitude frequency characteristic graph indication

Filter

No. of adjustment bands : 2 bands, 8 bands, 12 bands

Filter Type	Center Frequency	Boost/Cut	Q
PEQ	20 Hz to 20 kHz 1/24 octave band or continuous variable type (effective figure: 3 digits)	±12 dB 0.1 or 0.5 dB steps	0.267 - 69.249 (96points)

Filter Type	Cut-off Frequency	Q
HPF(6 dB) LPF(6 dB)	20 Hz to 20 kHz 1/24 octave band or	---
HPF(12 dB) LPF(12 dB)	continuous variable type(effective figure: 3 digits)	0.500 - 2.563 (51points)

Filter Type	Roll-off Frequency	Boost/Cut
High Shelving	6 Hz to 20 kHz 1/24 octave band or continuous variable type (effective figure: 3 digits)	±12 dB 0.1 or 0.5 dB steps
Low Shelving	20 Hz to 500 Hz 1/24 octave band or continuous variable type(effective figure: 3 digits)	±12 dB 0.1 or 0.5 dB steps

Filter Type	Center Frequency	Q
Notch	20 Hz to 20 kHz 1/24 octave band or continuous variable type (effective figure: 3 digits)	8.65, 9.89, 11.54, 13.85, 17.31, 23.08, 34.62, 69.25

Filter Type	Boost
Horn EQ	0 to +18 dB 0.5 dB steps

Additional function : Band-bypass function, Bypass-all function
Amplitude frequency characteristic graph indication

Delay

Delay time : 0 - 682.6 ms (0.021 ms steps)
Additional function : Distance input (meter, feet, inch)

Crossover(2-way, 3-way, 4-way)

Slope Type	Cut-off Frequency	Q	Q2	
Through	None			
6 dB/oct	20 Hz to 20 kHz continuous variable type (effective figure: 3 digits)	---	---	
12 dB/oct Bessel, 12 dB/oct Butterworth 12 dB/oct Linkwitz-Riley				
12 dB/oct Variable - Q		0.500 - 2.563 (51points)		
18 dB/oct Bessel, 18 dB/oct Butterworth		---		
18 dB/oct Variable - Q		0.500 - 2.563 (51points)		
24 dB/oct Bessel, 24 dB/oct Butterworth 24 dB/oct Linkwitz-Riley		---		
24 dB/oct Variable - Q		0.500 - 2.563 (51points)		0.500 - 2.563 (51points)

Gain : +12 dB to -60 dB, -∞dB 0.5 dB steps, polarity inversion possible
 Delay : Maximum 682.6 ms

Level(Attn)

Variable range : 0 dB to -60 dB, -∞dB 0.5 dB steps

Muting

Provided in each output channel

Microsoft, MS, MS-DOS, Windows, and Windows NT are a trade mark of Microsoft Corporation.

